

DENTAL INSTRUMENTS CATALOGUE
www.dsurgicalinstruments.com

50



Extracting Forceps, American Pattern
Zahnzangen, Amerikanische Form
Daviers, forme américaine
Forceps de extracción, forma americana
Pinze per estrozione, forma americana

Page 01 to 15

51



Extracting forceps, English pattern
Zahnzangen, Englische Form
Daviers, forme anglaise
Fórceps dentales, forma inglesa
Pinze per estrazione, forma inglese

Page 16 - 38

52



Root Elevators
Wurzelheber
Elévateurs á racines
Botadores para raíces
Leve per radici

Page 40 to 54

53



Bone Files
Bone-Dateien
Archivos de huesos
Fichiers d'os
Bone Files

Page 55 to 56

54



Dental Probes
Zahnsonden
Sondas dentales
Sondes dentaires
Sonde dentali

Page 57 to 58

55

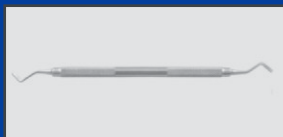

Enamel Instruments
Emaile-Instrumente
Instrumentos de esmalte
Instruments d'émail
Strumenti per smalto

Page 59 to 62

56



Dental Scalers
Zahnsteinentferner
Escaladores dentales
Scalers dentaires
Scaler dentali

Page 63 to 78

57



**Bone Currettes
Knochenküretten
Curetas de hueso
Currettes osseuses
Curette d'ossa**

Page 79 to 84

58



**Excavators
Bagger
Excavadoras
Pelles
escavatori**

Page 85 to 89

59



**Wax Proclein
Wachs-Porzellan
cera Porcelana
Cire Porcelaine
Cera porcellana**

Page 90 to 94

60



**Filling Instruments
Füllungsinstrumente
Actos de llenado
Instruments de remplissage
Strumenti di riempimento**

Page 95 to 105

61



**Gingivectomy Knives
Gingivektomie Messer
Cuchillos de gingivectomía
Couteaux de gingivectomie
Coltelli per gingivectomia**

Page 106 to 107

62



**Cement Spatulas
Zementspatel
Espátulas de cemento
Spatules de ciment
Spatole di cemento**

Page 108 to 112

63



**Mouth Mirrors
Mundspiegel
Espejos bucales
Bouche Miroirs
Bocca specchi**

Page 113 to 115

64



**Amalgam Instruments
Amalgam Instrumente
Instrumentos de amalgama
Instruments Amalgam
Strumenti amalgama** **Page 116 to 117**

65



**Matrix Retainers
Matrix-Halterungen
Retenedores de matrices
Retenue de matrice
Matrix Retainers** **Page 118 to 125**

66



**Hemostatic Forceps
Arterienklemmen
Pincas hemostaticas
Pinzashemostaticas
Pinze emostatiche** **Page 126 to 132**

67



**Towel Clamps
Handtuchklammern
Abrazaderas de toalla
Pincas à serviettes
Morsetti per asciugamano** **Page 133 to 134**

68



**Needle Holders
Nadelhalter
Porte-aiguilles
Porta-agujcs
Port' aghi** **Page 135 to 143**

69



**Retractors
Wundhaken
Ecarteurs
Separadores
Divaricatori** **Page 144 to 148**

70

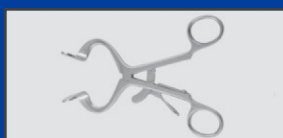

**Mouth and Tongue
Mund und Zunge
Boca y la lengua
Bouche et langue
Bocca e la lingua** **Page 149 to 152**

71



**Scissors
Schere
Tijeras
Les ciseaux
Forbici**

Page 153 to 168

72



**Micro Scissors
Mikroschere
Micro tijeras
Micro-ciseaux
Micro forbici**

Page 169 to 170

73



**Orthodontics
Kieferorthopädie
Ortodoncia
Orthodontie
Ortodonzia**

Page 171 to 187

74



**Bone Rongeurs
Knochen Rongeur
Rongeurs de hueso
Os Rongeurs
Bone Rongeurs**

Page 188 to 190

75



**Forceps
Zange
Fórceps
Forceps
forcipe**

Page 191 to 198

76



**Scalpel Handles
Skalpellgriffe
Manches de bistouris
Mangos de Bisturías
Manici per bisturi**

Page 199 to 200

77



**Mallets
Schlägel
Mazos
Maillets
Mallets**

Page 201 to 203

78



**Cassettes
Kassetten
Cassettes
Cassettes
cassette**

Page 204 to 207

79

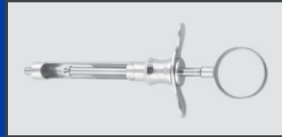

**Cylinder cartridge syringe
Zylinder-Ampullenspritze
Seringue á ampoule cylindrique
Jeringo para cartucho ampollas
Siringe ampollare a cilindro**

Page 208 to 213

80

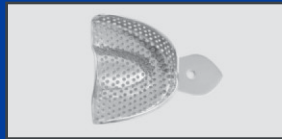

**Impression Trays
Abdrucklöffel
Porte empreintes
Cubetas para impresiones
Portaimpronte**

Page 214 to 225

81



**Articulators
Artikulatoren
Articuladores
Articulateurs
articolatori**

Page 226 to 227

82



**Holloware
Holloware
holloware
Platerie
Holloware**

Page 228 to 231

50

- EN** Extracting Forceps, American Pattern
- DE** Zahnzangen, Amerikanische Form
- ES** Daviers, forme américaine

Page 01 to 15

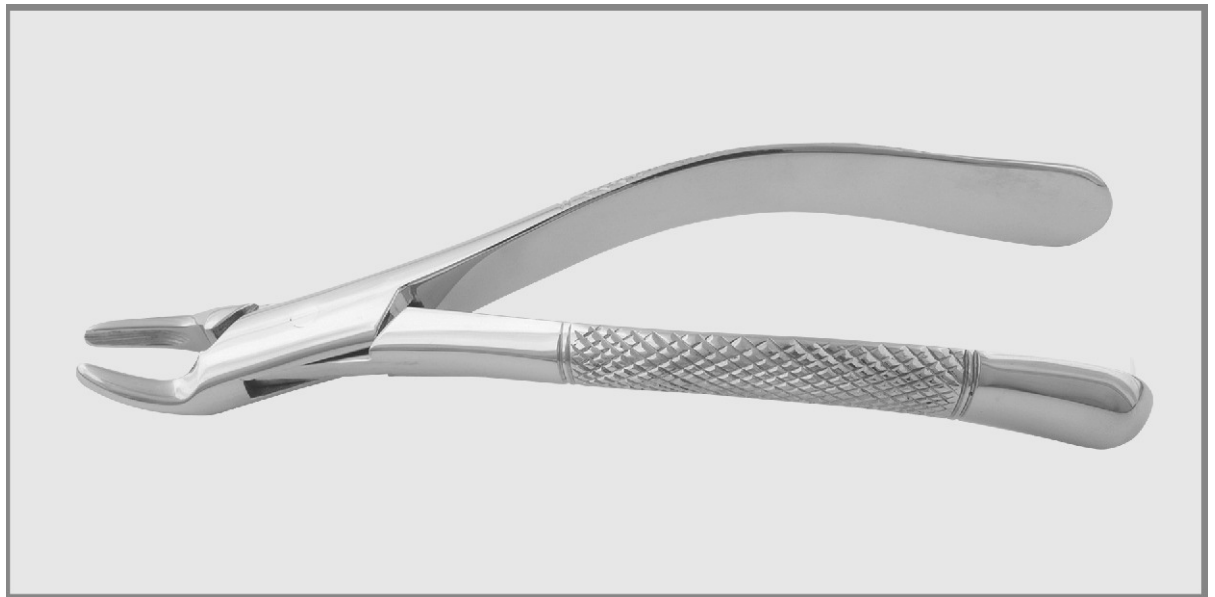
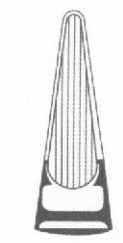



Fig. 1



DS-50-1001



HENAHAN
Fig. 1 A



DS-50-1002



Fig. 1 B



DS-50-1003



MILWAUKEE
Fig. 3

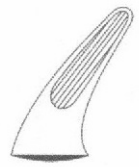

DS-50-1004



WOOD-WARD
Fig. 3 FH

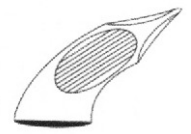

DS-50-1005



DS-50-1006

WOOD-WARD
Fig. 3 FS



DS-50-1007

PHYSICK
Fig. 5

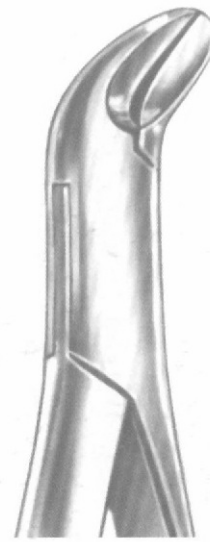
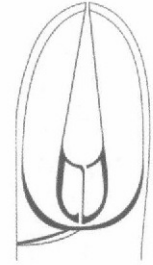

Fig. 6



DS-50-1008



Fig . 10 H

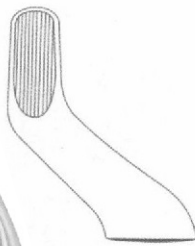

DS-50-1009



Fig . 10 S

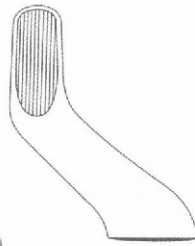

DS-50-1010



HARRIS
Fig . 15



DS-50-1011



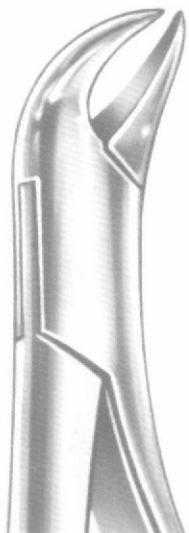

HARRIS
Fig. 16

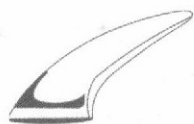

DS-50-1012



Fig. 16 S



DS-50-1013



Fig. 17



DS-50-1014



HARRIS
Fig. 18 L

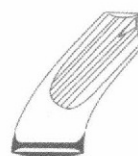

DS-50-1015



HARRIS
Fig. 18 R



DS-50-1016

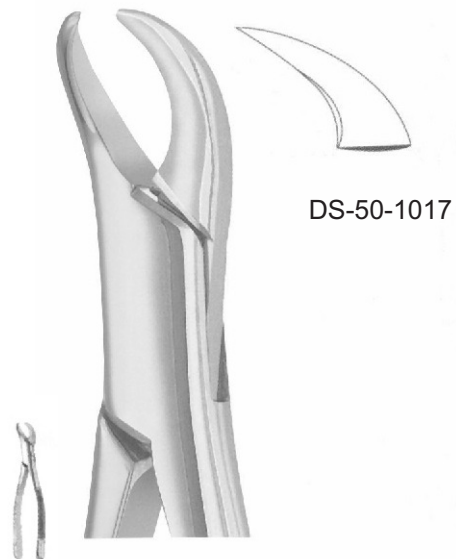

DS-50-1017

Fig. 23

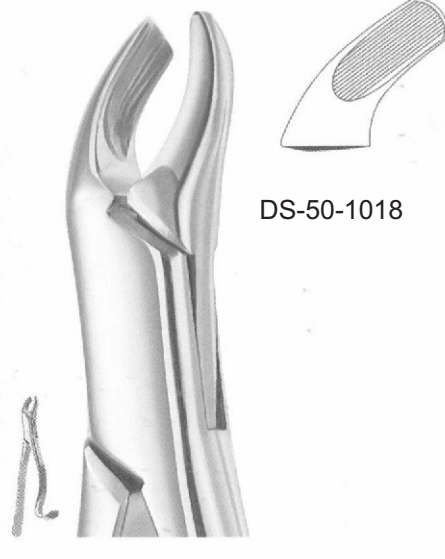

DS-50-1018

Fig. 24

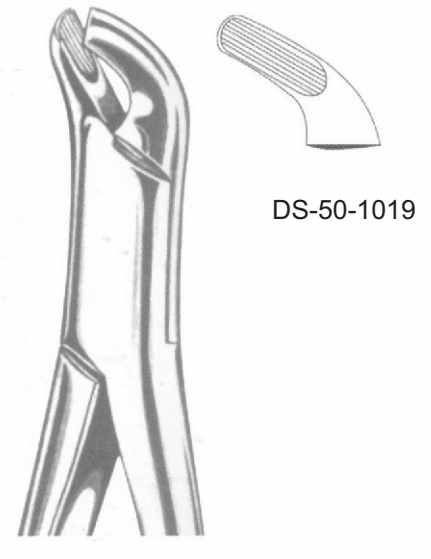

DS-50-1019

Fig. 27

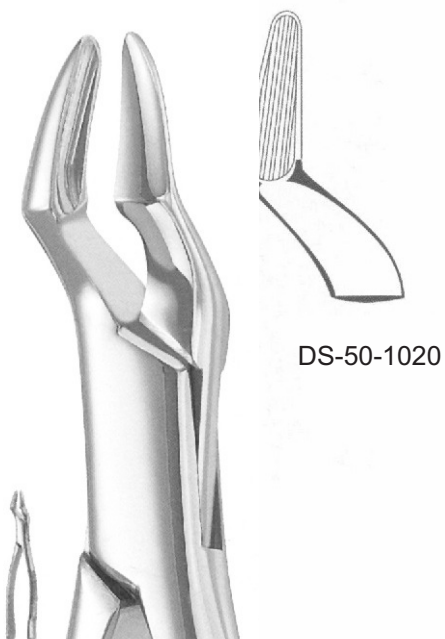

DS-50-1020

PARMLY
Fig. 32



DS-50-1021

PARMLY
Fig. 32 A

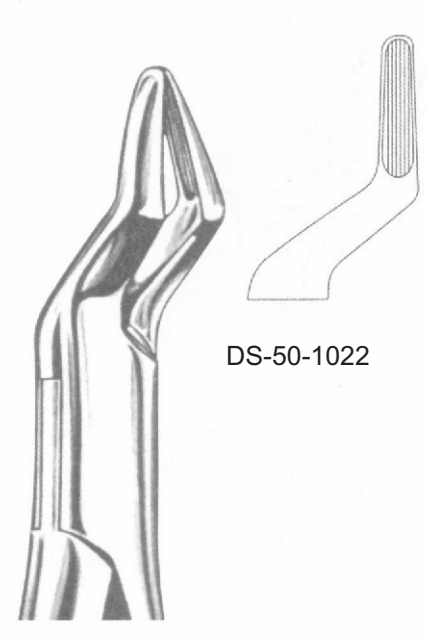

DS-50-1022

Fig. 35

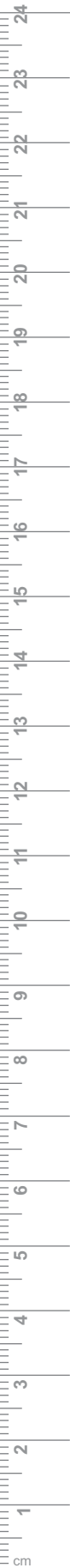



DS-50-1023

Fig. 53 L



DS-50-1024

Fig. 53 R



Fig. 62



DS-50-1025



Fig. 65

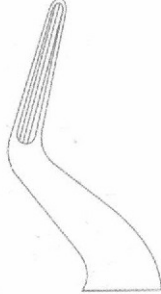

DS-50-1026



TOMES
Fig. 69



DS-50-1027



THOMAS
Fig. 85



DS-50-1028



THOMAS
Fig. 85 A



DS-50-1029





NEVIUS
Fig. 88 L



DS-50-1030



NEVIUS
Fig. 88 R

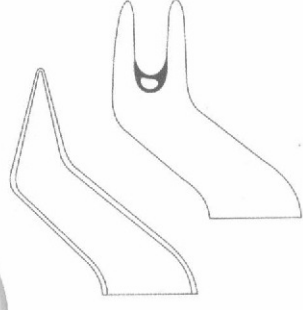

DS-50-1031



KELLS
Fig. 99 A

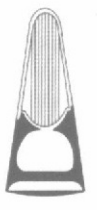

DS-50-1032



KELLS
Fig. 99 C

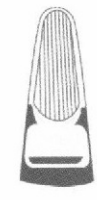

DS-50-1033



HULL
Fig. 101



DS-50-1034



Fig. 103

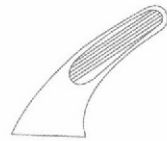

DS-50-1035



Fig. 10 H



DS-50-1036



Fig. 10 S



DS-50-1037



CRYER
Fig. 150



DS-50-1038

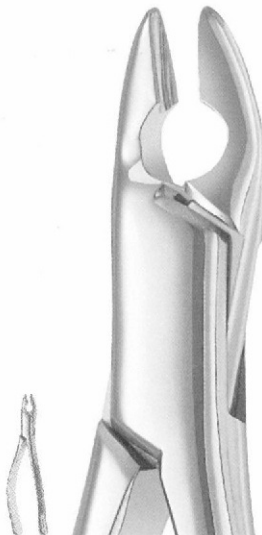

CRYER
Fig. 150 A



DS-50-1039



Fig. 150 X

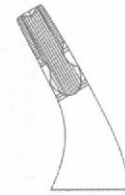

DS-50-1040

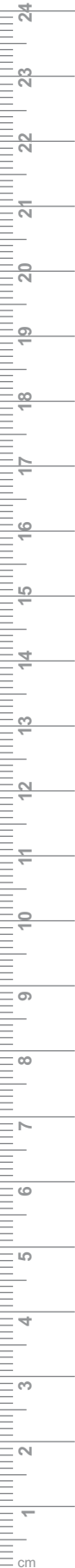



DS-50-1041



DS-50-1042



DS-50-1043

Fig. 150 AB

Fig. 150 AS

CRYER
Fig. 150 S

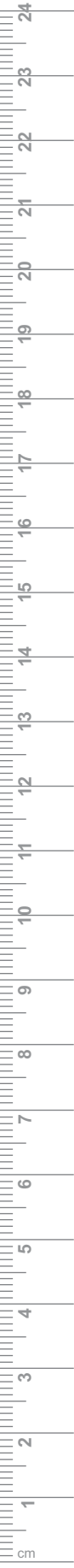

CRYER
 Fig. 151

DS-50-1044



CRYER
 Fig. 151 A



DS-50-1045

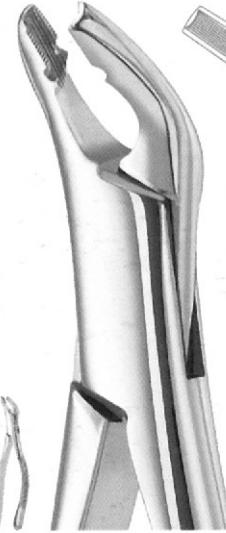
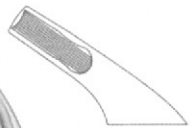

Fig. 151 X

DS-50-1046



CRYER
 Fig. 151 AB

DS-50-1047

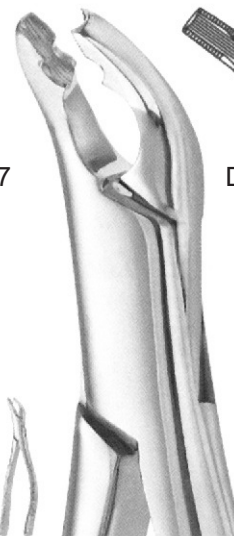
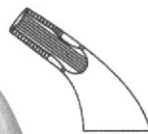

Fig. 151 AS

DS-50-1048



CRYER
 Fig. 151 S

DS-50-1049

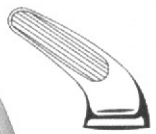





Fig.201

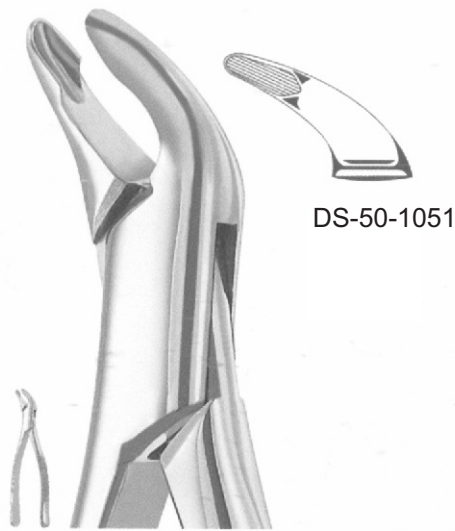

Fig.203

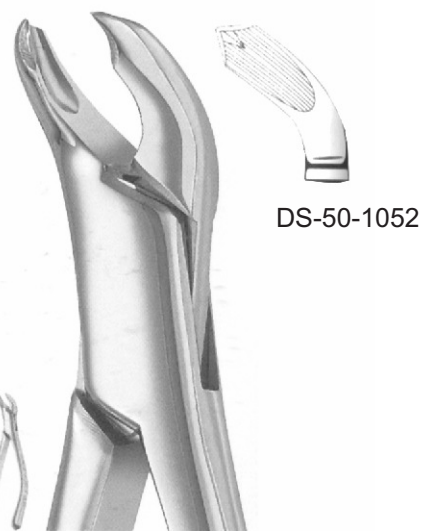

Fig.217

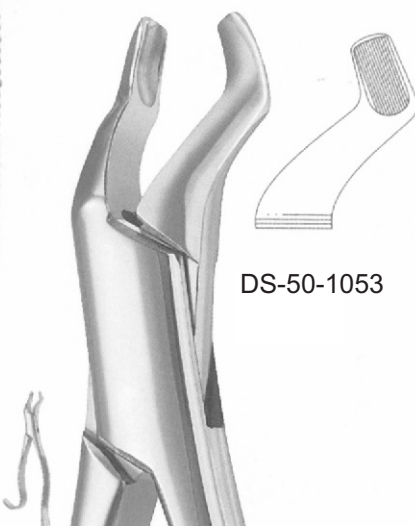

Fig.210 H

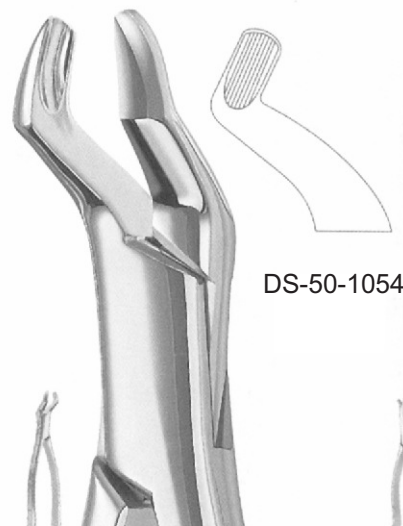
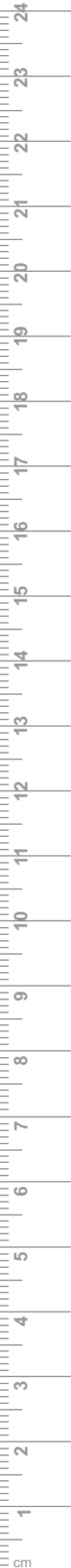

Fig.210 S



Fig.222



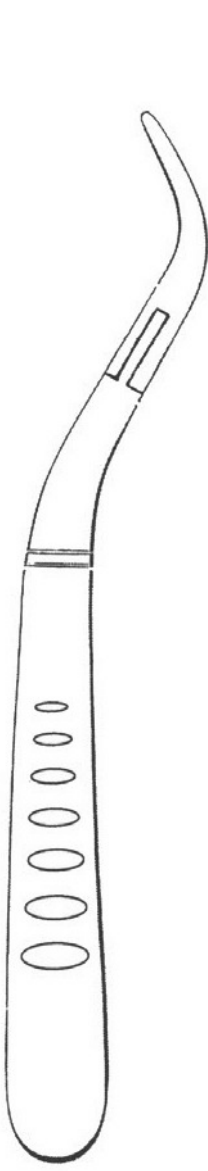

Fig.300



DS-50-1059

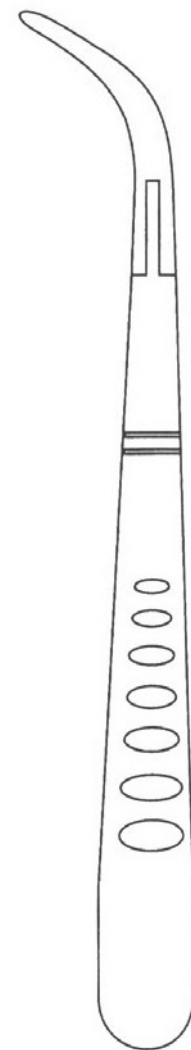
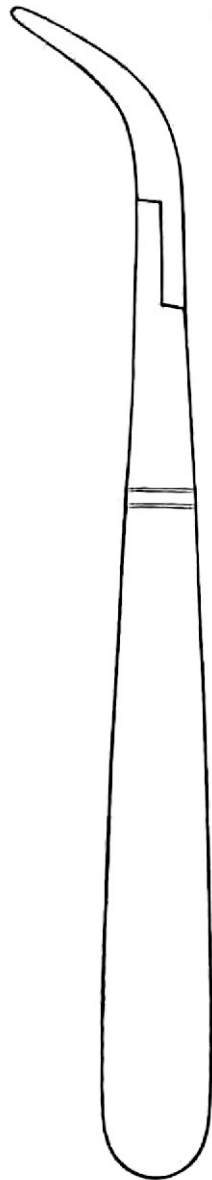

Fig.301



DS-50-1060



DS-50-1061
WITZEL
Fig.501

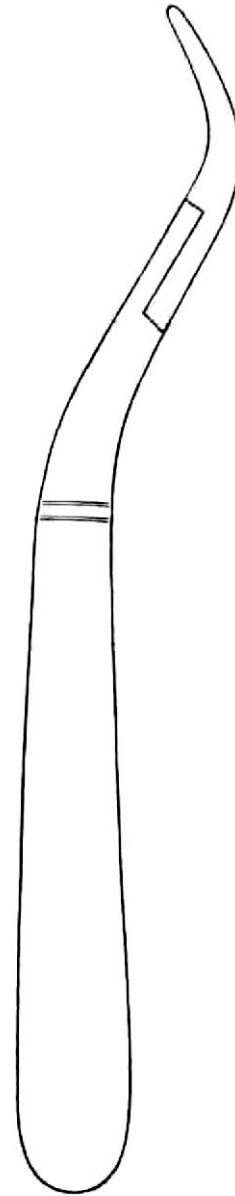

DS-50-1062
WITZEL
Fig.502





DS-50-1063

Fig. 17 SK



DS-50-1064

Fig. 23 SK



DS-50-1065

Fig. 150 Sk



DS-50-1066

Fig. 151 Sk



51

- EN** Extracting forceps, English pattern
- DE** Zahnzangen, Englische Form
- ES** Daviers, forme anglaise

Page 16 - 38

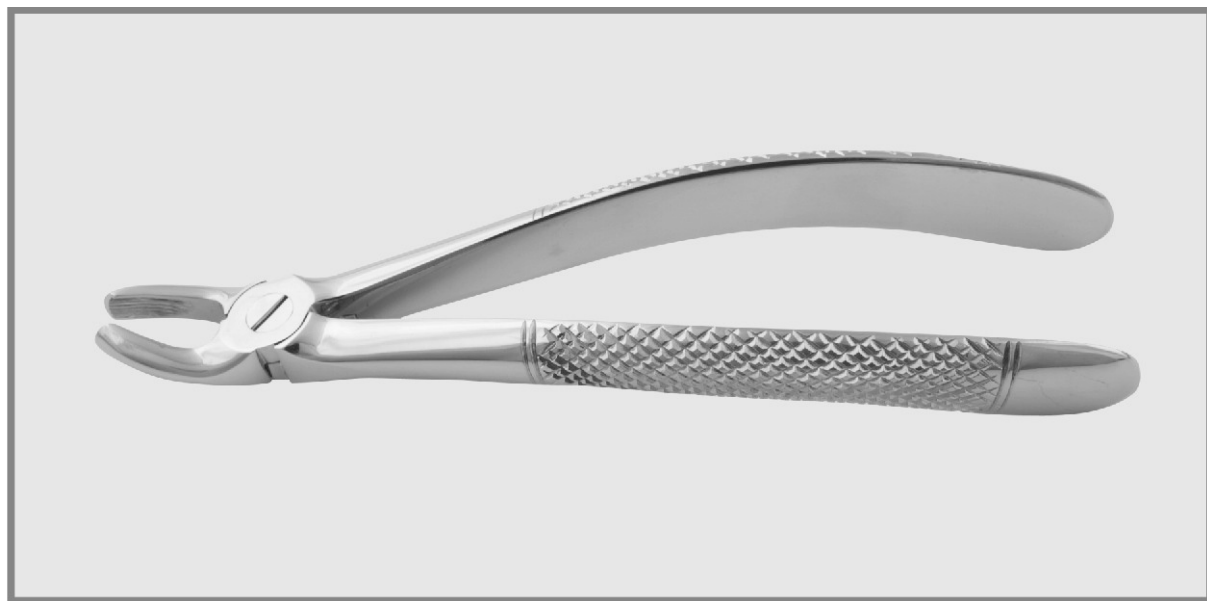
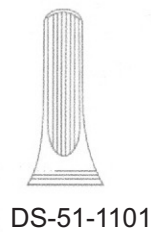



Fig. 1



DS-51-1101



Fig. 2

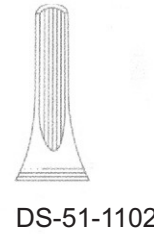

DS-51-1102



Fig. 3

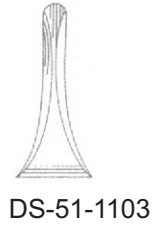

DS-51-1103



Fig. 4

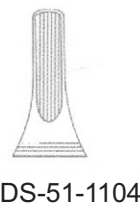

DS-51-1104



Fig. 7

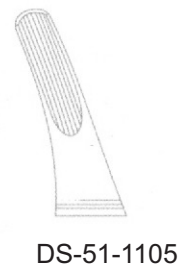

DS-51-1105

EXTRACTING FORCEPS ENGLISH



DS-51-1106

Fig. 8



DS-51-1107

Fig. 13



DS-51-1108

Fig. 17



DS-51-1109

Fig. 18



DS-51-1110

Fig. 18 A



DS-51-1111

Fig. 19

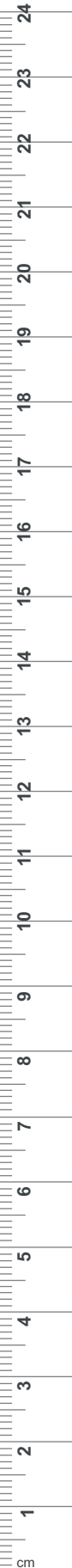
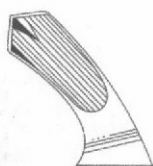



Fig. 20



DS-51-1112



Fig. 21

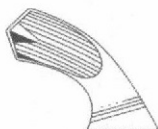

DS-51-1113



Fig. 22



DS-51-1114



Fig. 23

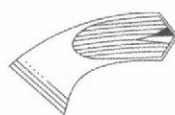

DS-51-1115



Fig. 24

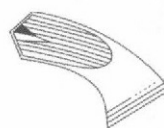

DS-51-1116

EXTRACTING FORCEPS ENGLISH



Fig. 29

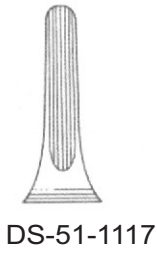

DS-51-1117



Fig. 29 N

DS-51-1118



Fig. 30



DS-51-1119



Fig. 31

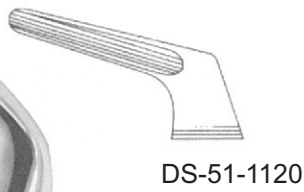

DS-51-1120



Fig. 32
DS-51-1121

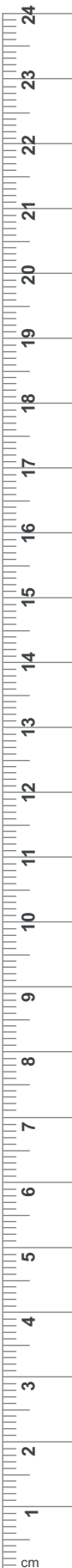
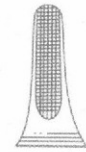



Fig. 33



DS-51-1122



Fig. 33 A



DS-51-1123



Fig. 33 C

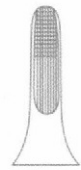

DS-51-1124



Fig. 33 M



DS-51-1125



Fig. 33 W



DS-51-1126



DS-51-1127

Fig. 34



DS-51-1128

Fig. 35



DS-51-1129

Fig. 36

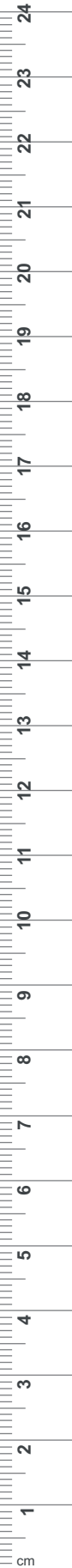



Fig. 41

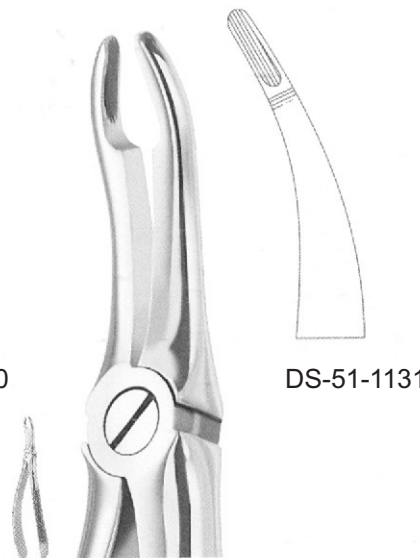
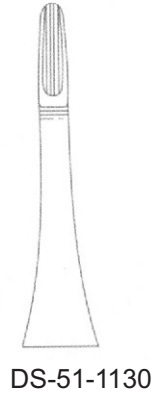

Fig. 44

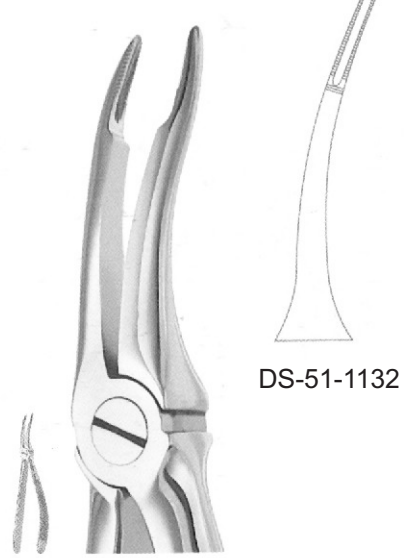
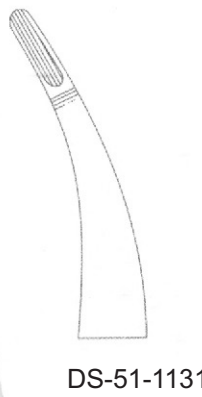

Fig. 44 F

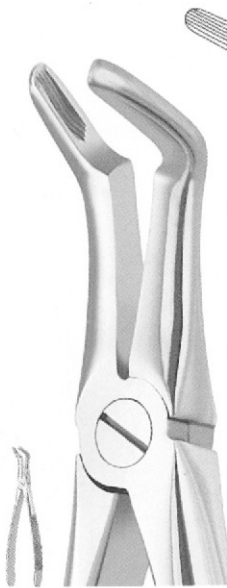
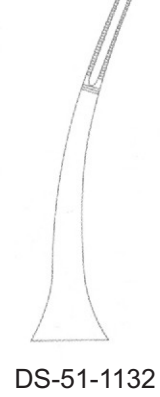

Fig. 45



Fig. 45 F

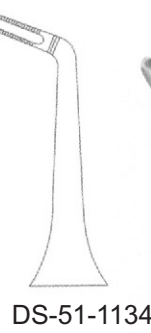
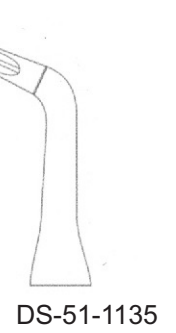

Fig. 46 L



EXTRACTING FORCEPS ENGLISH



Fig. 51

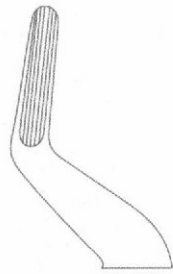

DS-51-1136



Fig. 51 A

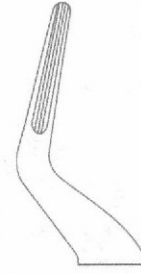

DS-51-1137



Fig. 51 C

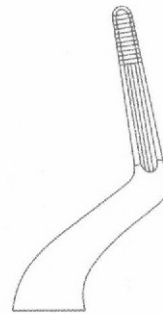

DS-51-1138



Fig. 51 L

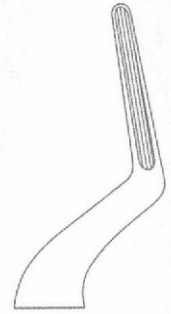

DS-51-1139

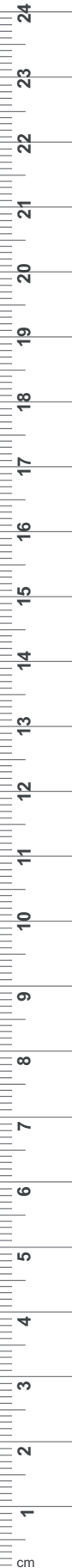



DS-51-1140

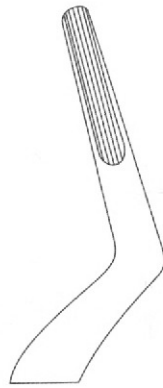

DS-51-1141

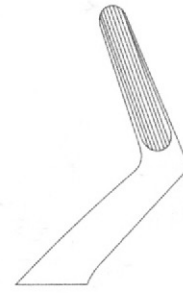
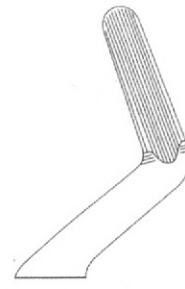

Fig. 52



DS-51-1142



DS-51-1143

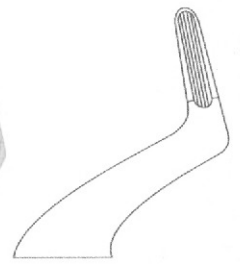

Fig. 51 M

Fig. 52 A

Fig. 53



Fig. 55



DS-51-1144

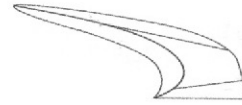
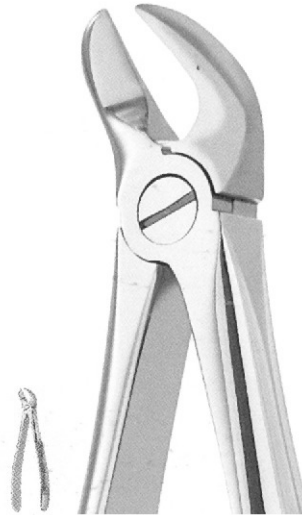

DS-51-1145

Fig. 56

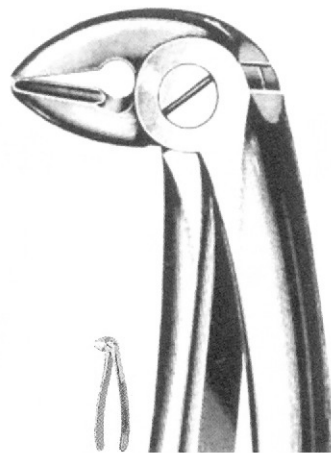

breit
broad



DS-51-1146

BUSCH
Fig. 59



schmal
narrow



DS-51-1147

BUSCH
Fig. 60

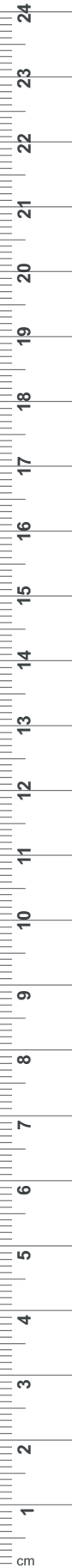



DS-51-1148



DS-51-1149

Fig. 67

Fig. 67 A

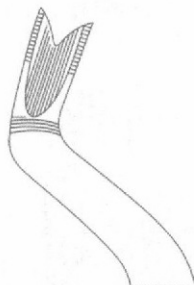

DS-51-1150

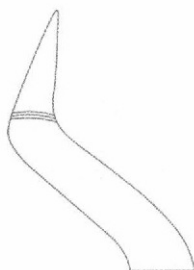

DS-51-1151

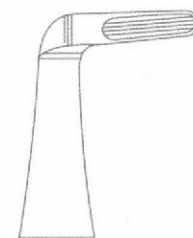

DS-51-1152

Fig. 67 LX

Fig. 67 RX

RYDING
Fig. 68

EXTRACTING FORCEPS ENGLISH



Fig. 73



Fig. 74



Fig. 74 M



Fig. 74N



Fig. 75





DS-51-1158

LAWRENCE-READ
Fig. 76



DS-51-1159

LAWRENCE-READ
Fig. 76 N

EXTRACTING FORCEPS ENGLISH

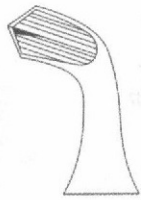

DS-51-1160

Fig. 79



DS-51-1161

Fig. 79 A



DS-51-1162

Fig. 86 A

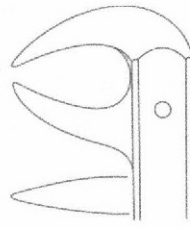

DS-51-1163

Fig. 86 B

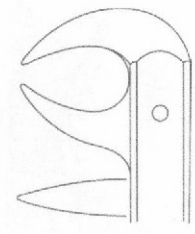

DS-51-1164

Fig. 86 C

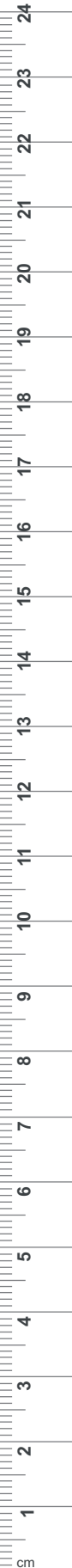



Fig. 87

DS-51-1165



Fig. 89

DS-51-1166

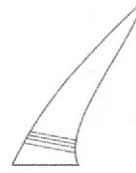

Fig. 90

DS-51-1167

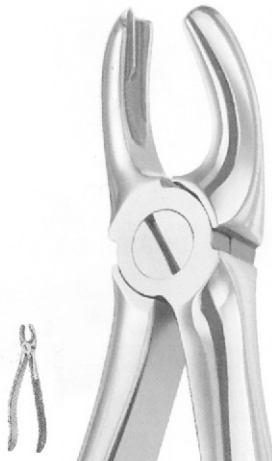
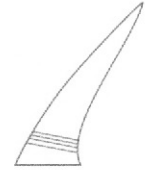

Fig. 94

DS-51-1168



Fig. 95

DS-51-1169

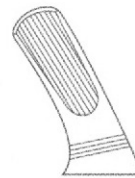

WOOD
Fig. 99

DS-51-1170



EXTRACTING FORCEPS ENGLISH



Fig. 113
DS-51-1171

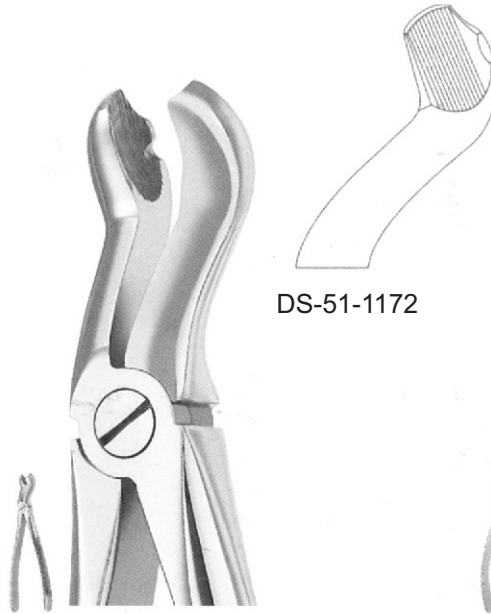

OGDEN FELSCH
Fig. 121



GUY
Fig. 136
DS-51-1173

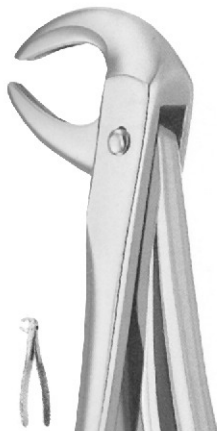

GUY
Fig. 137
DS-51-1174



Fig. 160
DS-51-1175



Fig. 162
DS-51-1176

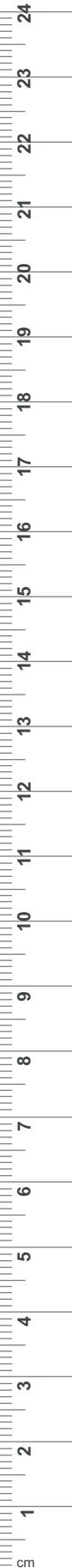



DS-51-1177
Fig. 233



DS-51-1178



DS-51-1179
Fig. 235

EXTRACTING FORCEPS ENGLISH



MEAD
Fig. MD 1



DS-51-1180

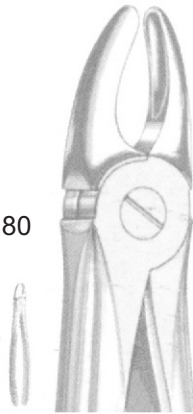

MEAD
Fig. MD 2



DS-51-1181



MEAD
Fig. MD 3



DS-51-1182



MEAD
Fig. MD 4



DS-51-1183

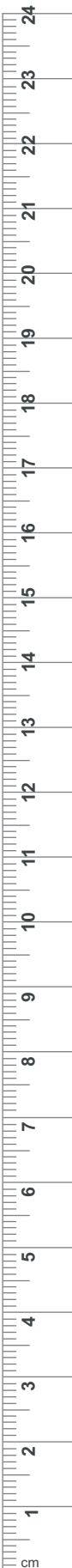

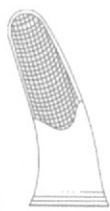

DS-51-1184

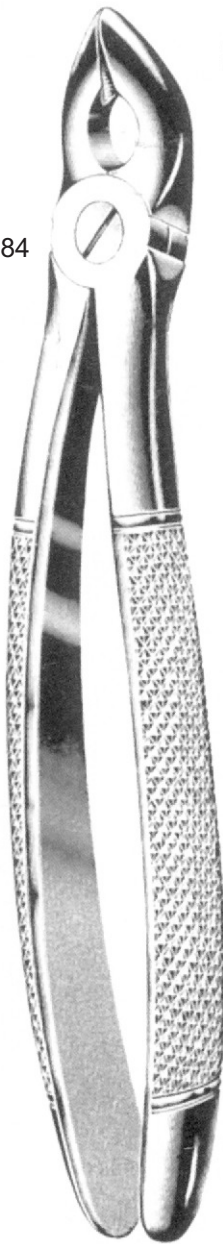

DS-51-1185

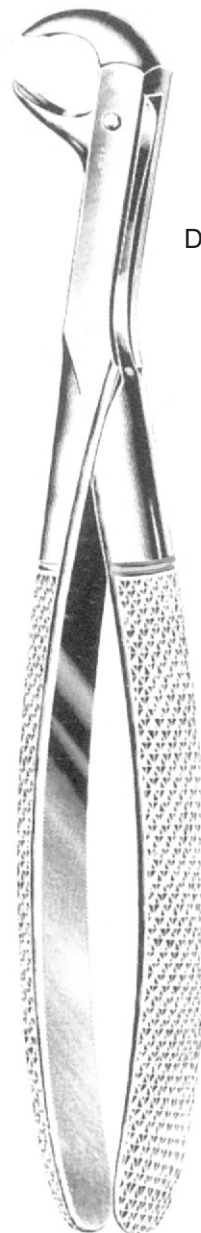

DS-51-1186

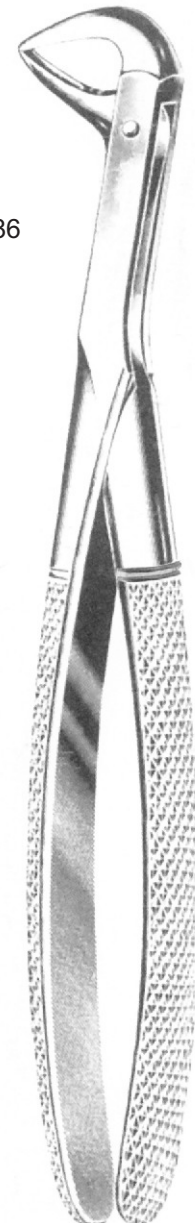

DS-51-1187

COHEN

COHEN

STIKSA

STIKSA

EXTRACTING FORCEPS ENGLISH

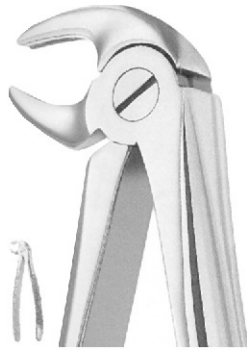

Fig. 13 S



Fig. 22 S

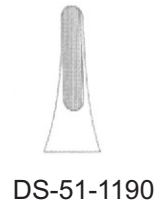
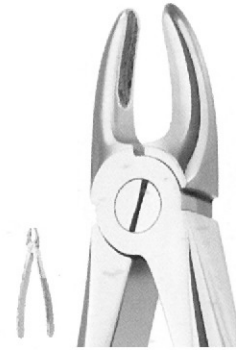

Fig. 29 S

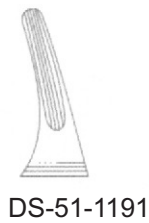

Fig. 30 S



Fig. 33 S



Fig. 37

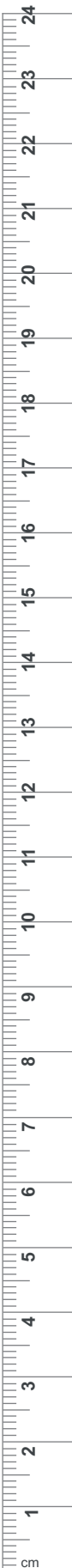

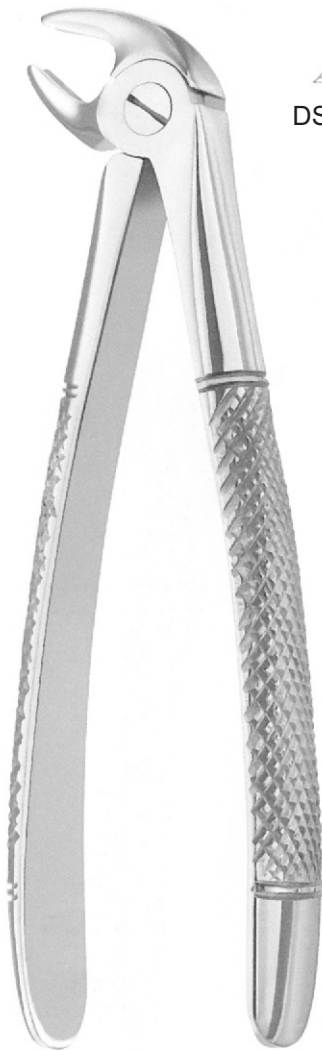

Fig. 38



Fig. 39

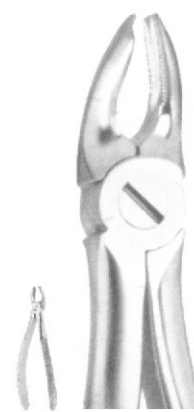

Fig. 39 A



Fig. 39 L



Fig. 39 R

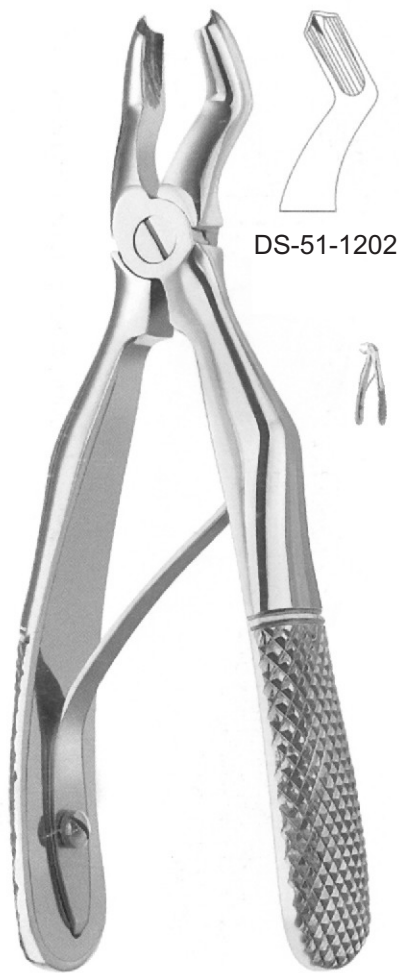



Fig. 40

Fig. 51 S

DS-51-1201
LAWRENCE-READ
Fig. 76 S



KLEIN
Fig. 3

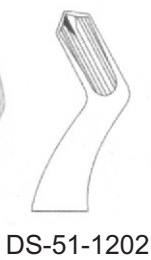

DS-51-1202



Fig. 5



DS-51-1203



Fig. 6



DS-51-1204



Fig. 7



DS-51-1205

EXTRACTING FORCEPS ENGLISH



DS-51-1206

KLEIN
Fig. 137



DS-51-1207

KLEIN
Fig. 139



DS-51-1208

KLEIN
Fig. 51 S



52

- EN** Root Elevators
- DE** Wurzelheber
- ES** Elevateurs á racines

Page 40 to 54

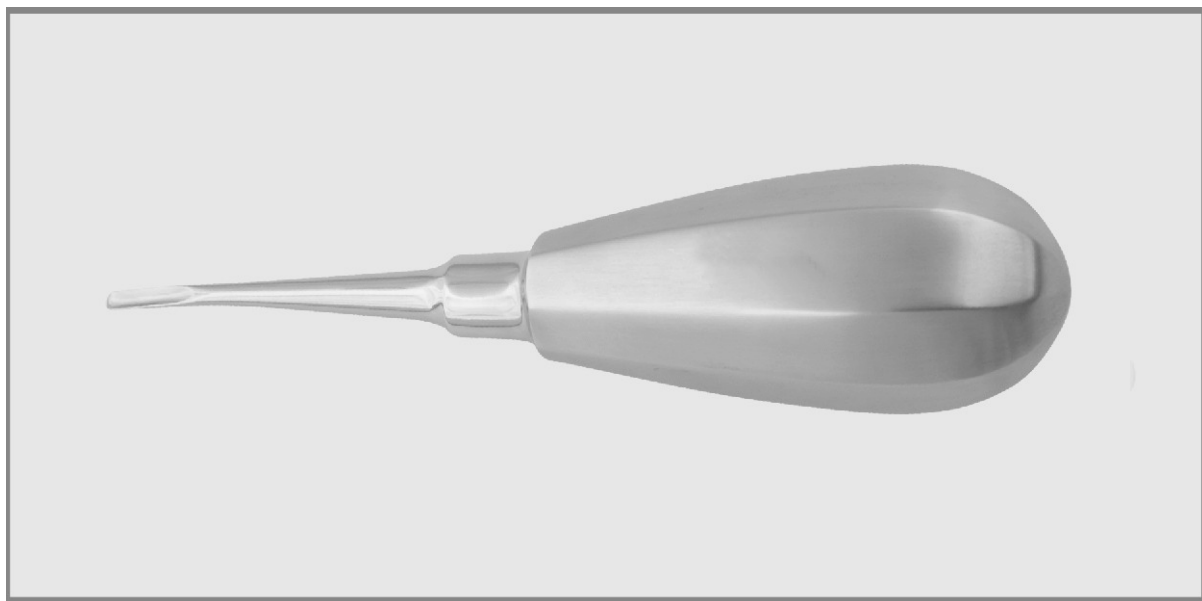

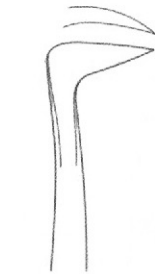

DS-52-1251
Fig. 1 L



DS-52-1252
Fig. 1 R



SALDIN
DS-52-1253
Fig. 2



SELDIN
DS-52-1254
Fig. 3

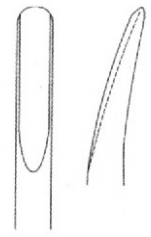

CRYER
DS-52-1255
Fig. 3 A



SELDIN
DS-52-1256
Fig. 4 L



SELDIN
DS-52-1257
Fig. 4 R



CRANE
(COGSWELL)
DS-52-1258
Fig. 6

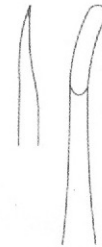

MILLER
DS-52-1259
Fig. 8



MILLER
DS-52-1260
Fig. 9



MILLER (Apexo)
DS-52-1261
Fig. 10



MILLER (Apexo)
DS-52-1262
Fig. 11

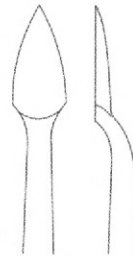

CRYER
DS-52-1263
Fig. 12



CRYER
 DS-52-1264
 Fig. 27



CRYER
 DS-52-1265
 Fig. 28



CRYER
 DS-52-1266
 Fig. 27 S



CRYER
 DS-52-1267
 Fig. 28 S



SELDIN
 DS-52-1268
 Fig. 34

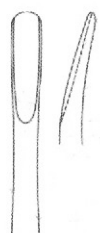

SELDIN
 DS-52-1269
 Fig. 34 S



CRYER
 DS-52-1270
 Fig. 39



CRYER
 DS-52-1271
 Fig. 40



FLOHR
 DS-52-1272
 Fig. 46



DS-52-1273
 Fig. 50

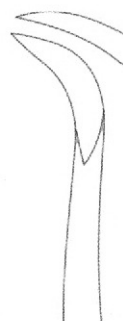

DS-52-1274
 Fig. 51

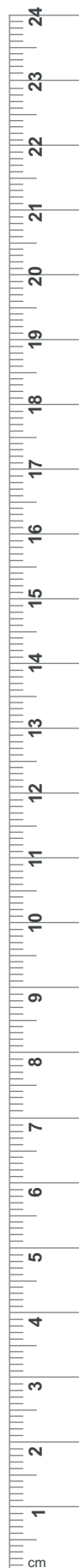

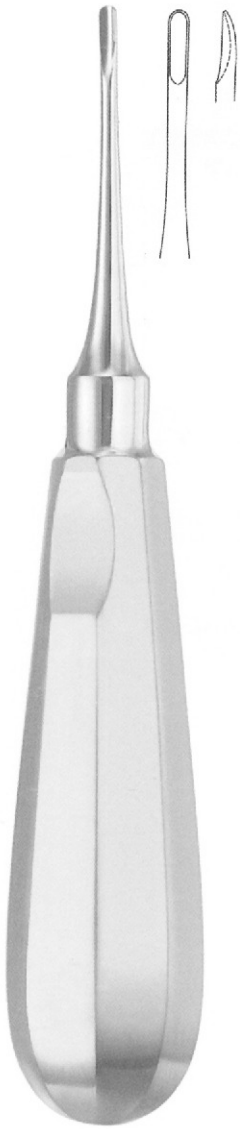

APICAL (Apexo)
 DS-52-1275
 Fig. 301

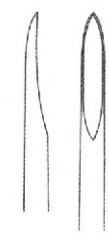
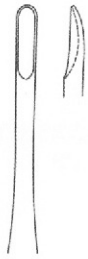

DS-52-1276
 Fig. 304

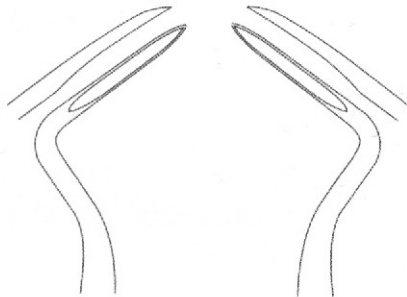

DS-52-1277
 Fig. 302

FLOHR
 DS-52-1278
 Fig. 303



COLEMAN



DS-52-1279
 Fig. 1



DS-52-1280
 Fig. 2 L

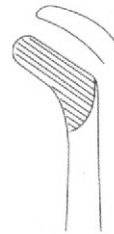

DS-52-1281
 Fig. 3 R

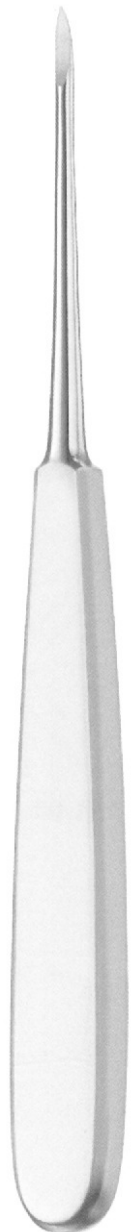

WARWICK JAMES
DS-52-1282
16 cm/6 1/4"



DS-52-1283
Fig. 2 L



DS-52-1284
Fig. 3 L



KOPP



DS-52-1285
Fig. 1



DS-52-1286
Fig. 2



DS-52-1287
Fig. 3



DS-52-1288
Fig. 4

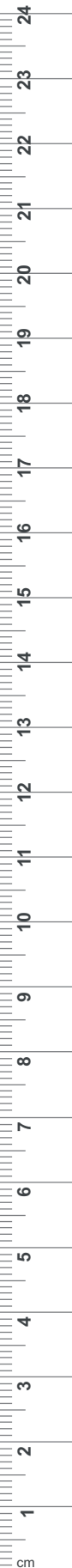



KOPP



DS-52-1289
Fig. 1



DS-52-1290
Fig. 2



DS-52-1293
Fig. 1



DS-52-1291
Fig. 3



DS-52-1292
Fig. 4

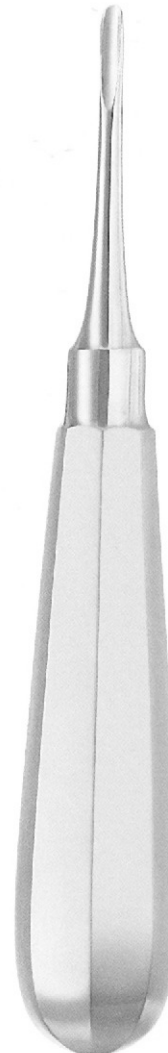

FLOHR



DS-52-1294
Fig. 2



DS-52-1295
Fig. 3



FRIEDMAN
 DS-52-1296
 Fig 1



DS-52-1297
 Fig. 2 L

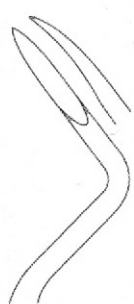

DS-52-1298
 Fig. .3 R



HYLIN
 DS-52-1299
 Fig. 1

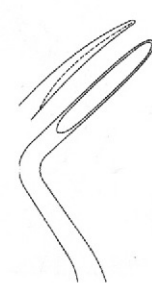

DS-52-1301
 Fig. 3 L

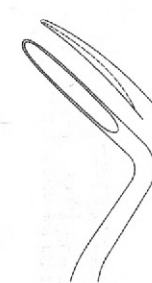

DS-52-1302
 Fig. 4 R

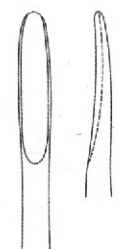

DS-52-1300
 Fig. 2





2 mm



DS-52-1303
Fig.0

3 mm



BEIN
DS-52-1304
Fig. 1

4 mm



DS-52-1305
Fig. 2

2 mm



DS-52-1306
Fig. 0

3 mm



BEIN
DS-52-1307
Fig. 1

4 mm

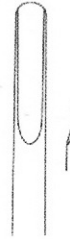

DS-52-1308
Fig. 2

2 mm



DS-52-1309
Fig. 0

3 mm



BEIN
DS-52-1310
Fig. 1

4 mm



DS-52-1311
Fig. 2

2 mm



DS-52-1312
Fig. 0 A

3mm



BEIN
DS-52-1313
Fig. 1 A

4 mm



DS-52-1314
Fig.2 A

2 mm

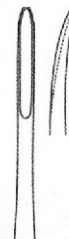

DS-52-1315
Fig.0 A

3 mm



BEIN
DS-52-1316
Fig. 1 A

4 mm



DS-52-1317
Fig. 2 A

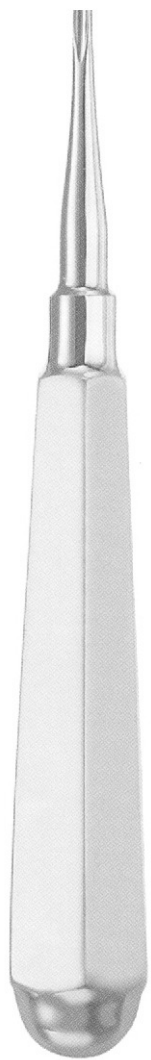

COUPLAND

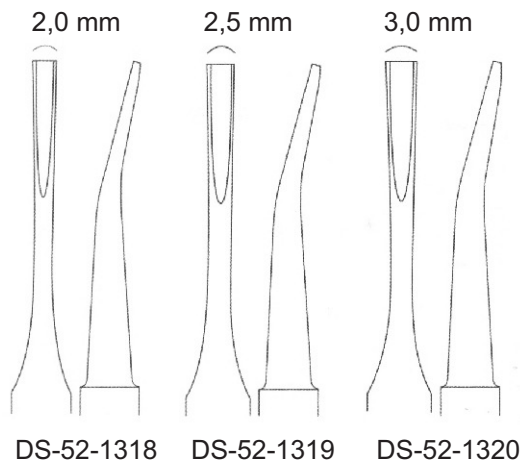

DS-52-1318

DS-52-1319

DS-52-1320

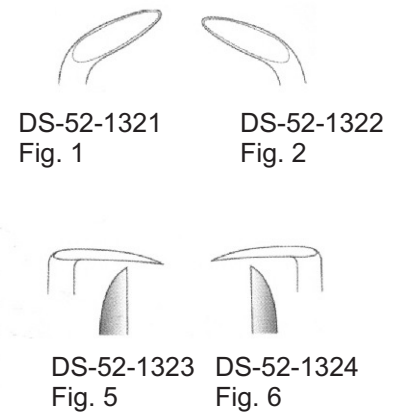

DS-52-1321
Fig. 1

DS-52-1322
Fig. 2

DS-52-1323
Fig. 5

DS-52-1324
Fig. 6

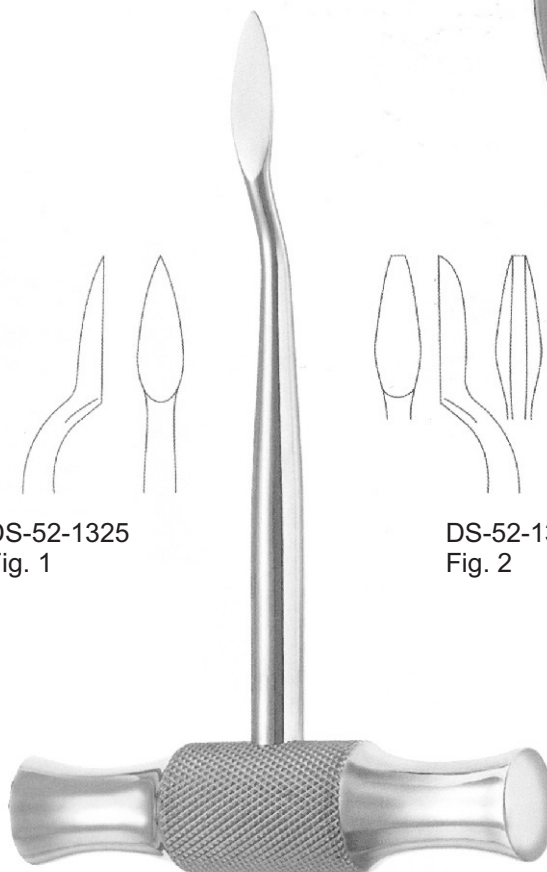

LECLUSE



LOOS

DS-52-1325
Fig. 1

DS-52-1326
Fig. 2

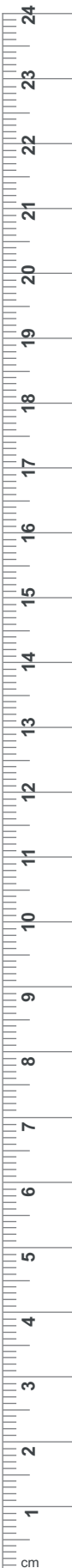



BARRY
11 cm/4 1/4"



DS-52-1327
Fig. 320 L



DS-52-1328
Fig. 321 R



DS-52-1329
Fig. 322



DS-52-1330
Fig. 323

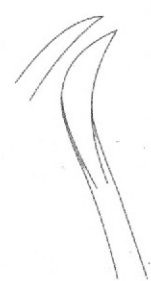

DS-52-1331
Fig. 370



DS-52-1332
Fig. 371



DS-52-1333
Fig. 1 L



DS-52-1334
Fig. 1 R



DS-52-1335
Fig. 11 L



DS-52-1336
Fig. 11 R



DS-52-1337
Fig. 12 L



DS-52-1338
Fig. 12 R



WINTER
11 cm/4 1/4"



DS-52-1339
Fig. 13 L



DS-52-1340
Fig. 13 R



DS-52-1341
Fig. 14 L



DS-52-1342
Fig. 14 R

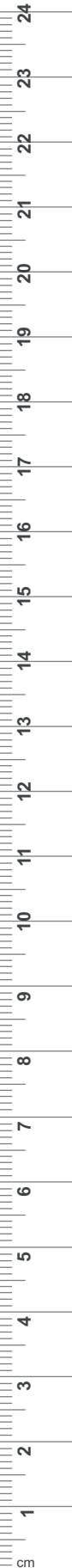

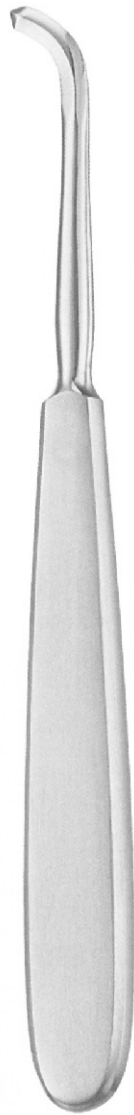

CHOMPRET



DS-52-1343
Fig. 1

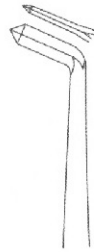

DS-52-1344
Fig. 2



DS-52-1345
Fig. 3



DS-52-1346
Fig. 4

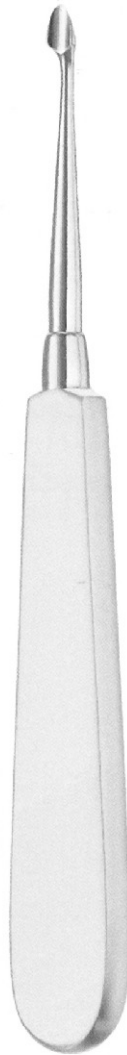

BERNARD



DS-52-1347
Fig. 0

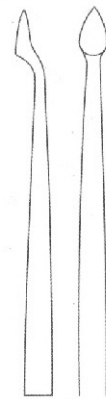

DS-52-1348
Fig. 1



DS-52-1349
Fig. 2

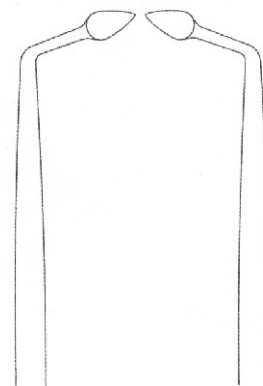

DS-52-1350
Fig. 6



DS-52-1351
Fig. 7

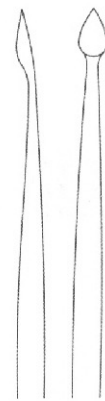

DS-52-1352
Fig. 11

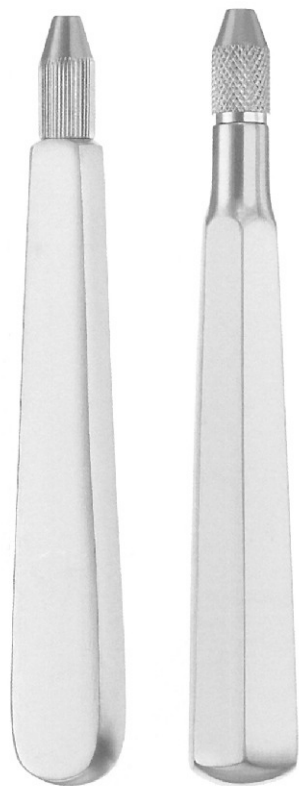

BERNARD
Handle # A

BERNARD
Handle # B



DS-52-1353
Fig. 1



DS-52-1354
Fig. 2



DS-52-1355
Fig. 3



DS-52-1356
Fig. 4



DS-52-1357
Fig. 5



DS-52-1358
Fig. 10



DS-52-1359
Fig. 8

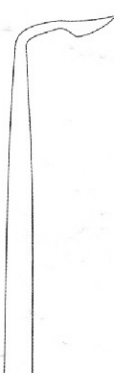

DS-52-1360
Fig. 9



DS-52-1361
Fig. 11

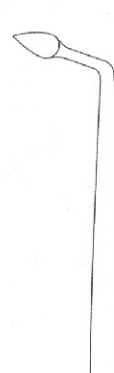

DS-52-1362
Fig. 7

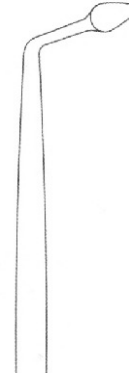

DS-52-1363
Fig. 6

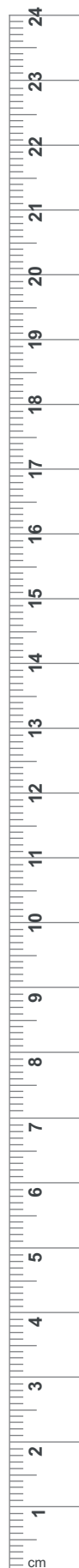

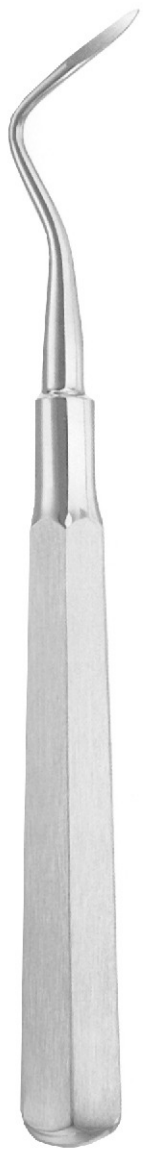

HEIDBRINK

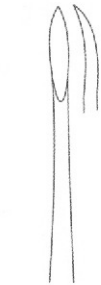

DS-52-1366
Fig. 1



DS-52-1367
Fig. 2



DS-52-1368
Fig. 3



WEST (Apical)



DS-52-1369
Fig. 1

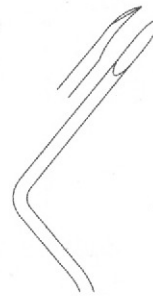

DS-52-1370
Fig. 2 R

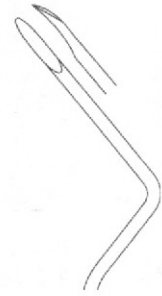

DS-52-1371
Fig. 3 L

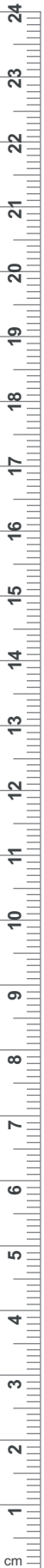



RATZOW



DS-52-1372
Fig. 1



DS-52-1373
Fig. 2



DS-52-1374
Fig. 3



HEIDBRINK

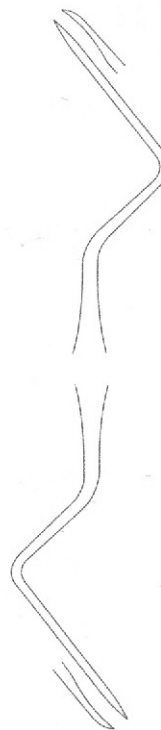

DS-52-1375
Fig. 1

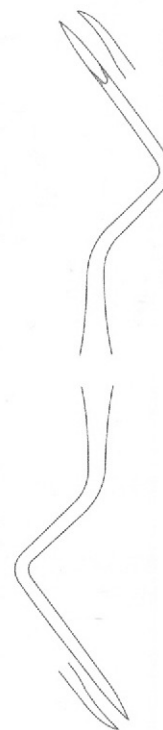

DS-52-1376
Fig. 2

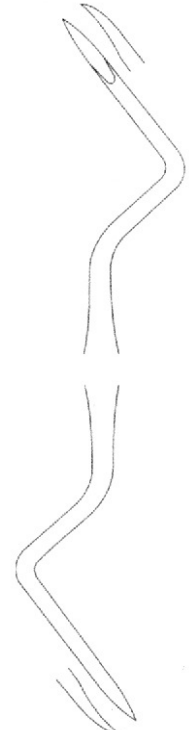

DS-52-1377
Fig. 23

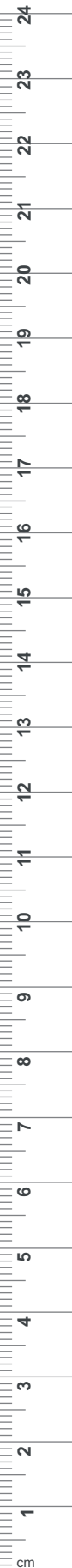



VIGNAL

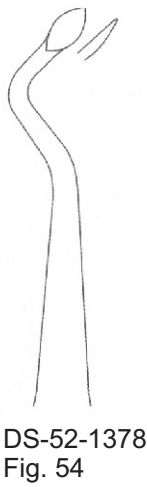

DS-52-1378
Fig. 54



DS-52-1379
Fig. 55

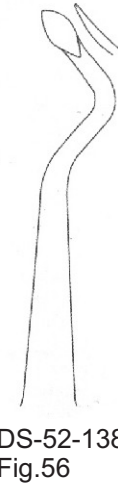

DS-52-1380
Fig. 56

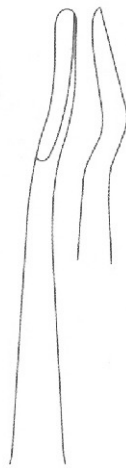

DS-52-1381
Fig. 57



DS-52-1382
Fig. 69

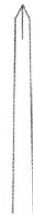

BARRY
21.5 cm/8 3/4"

4 mm



DS-52-1383

5 mm



DS-52-1384

6 mm



DS-52-1385

53

- EN** Bone Files
- DE** Bone-Dateien
- ES** Archivos de huesos

Page 55 to 56

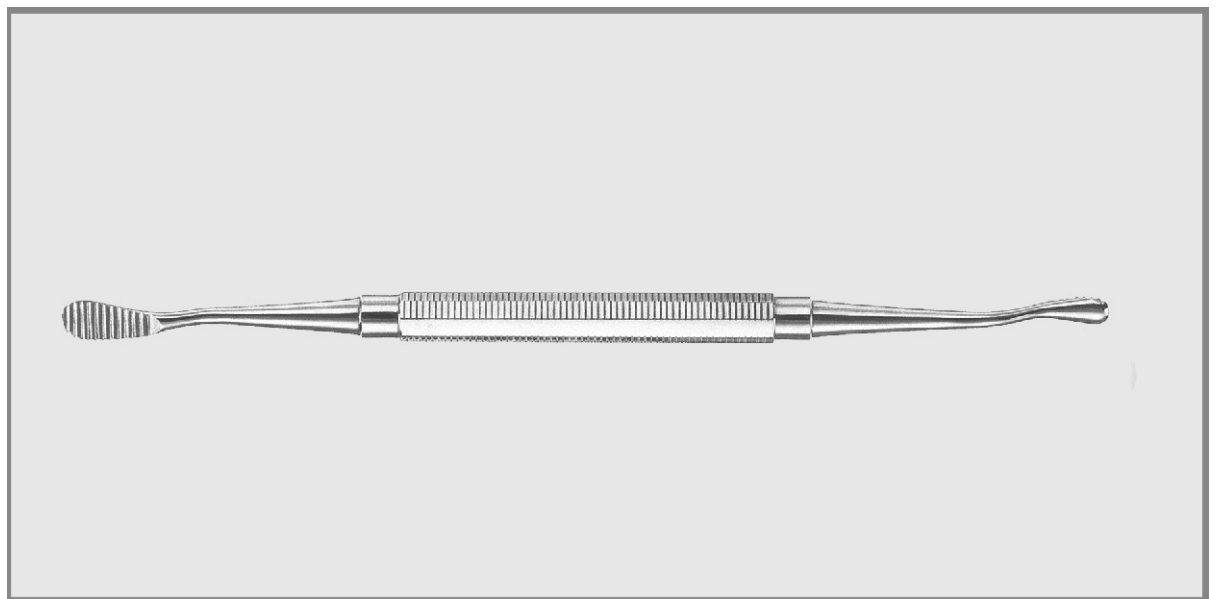

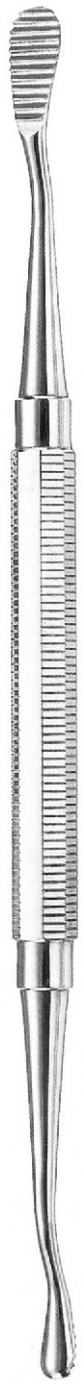

MILLER-COLBURN
18 cm/7"

downwards cutting

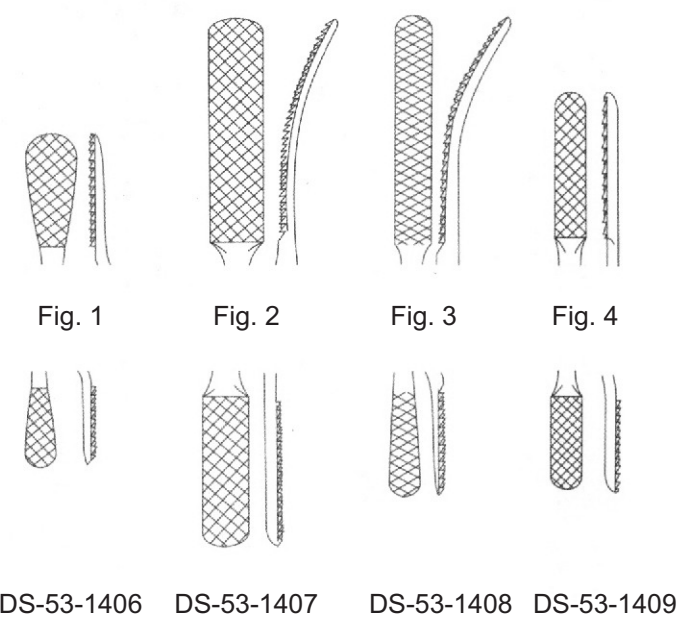
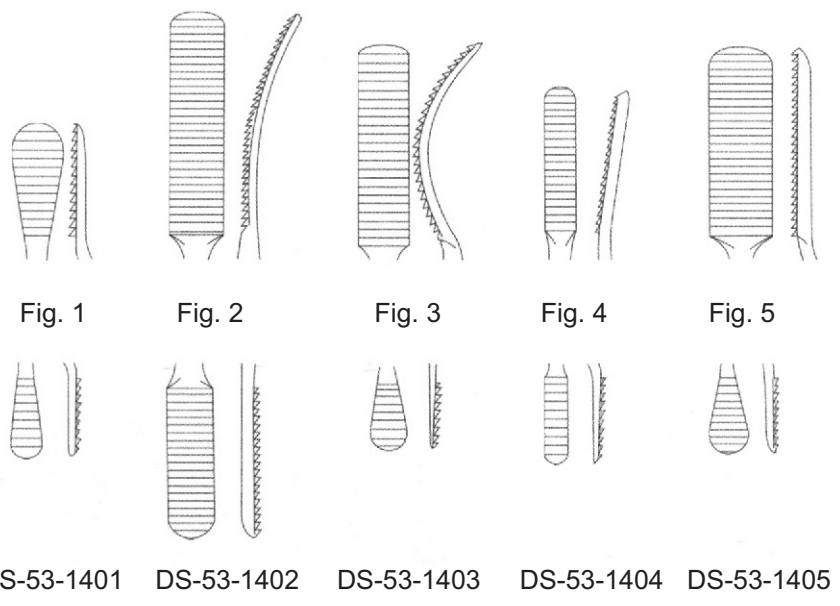

cross cut



MILLER-COLBURN
18 cm/7"

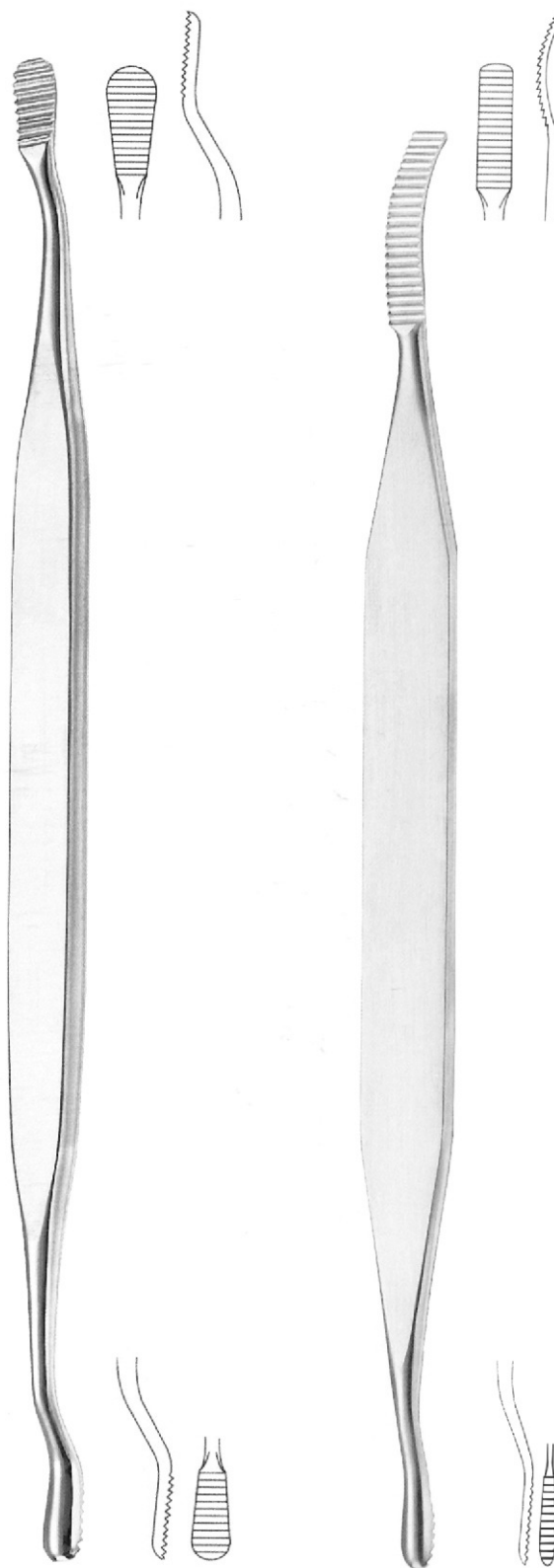

SELDIN
DS-53-1410
18 cm/7"
Fig. 11

SELDIN
DS-53-1411
18 cm/7"
Fig. 12



54

EN

Dental Probes

DE

Zahnsonden

ES

Sondas dentales

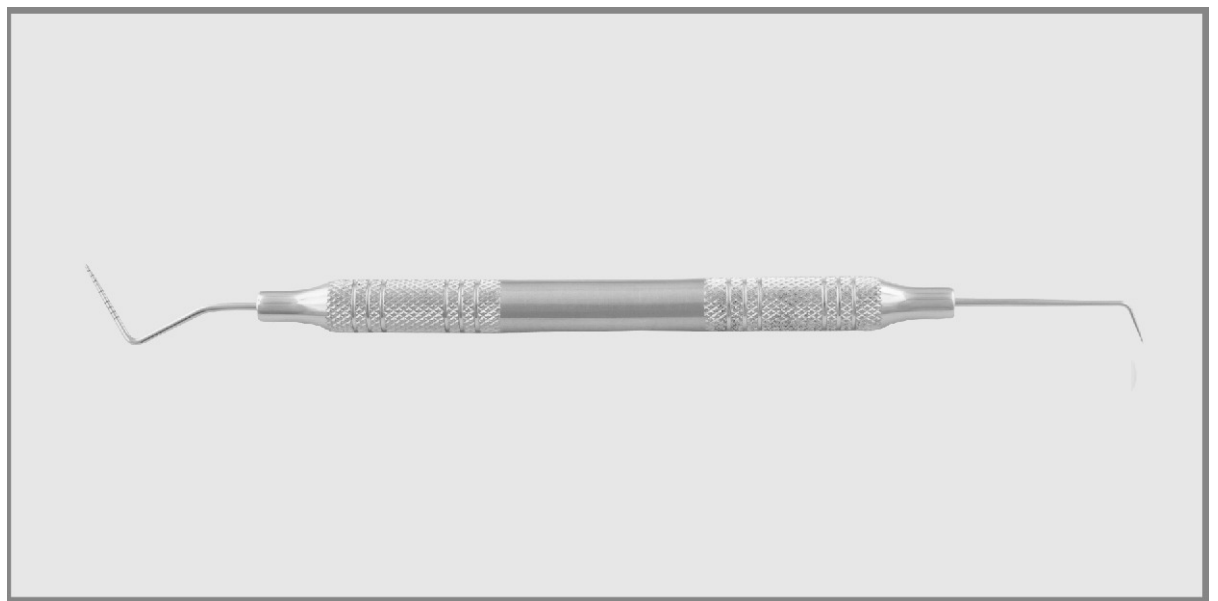

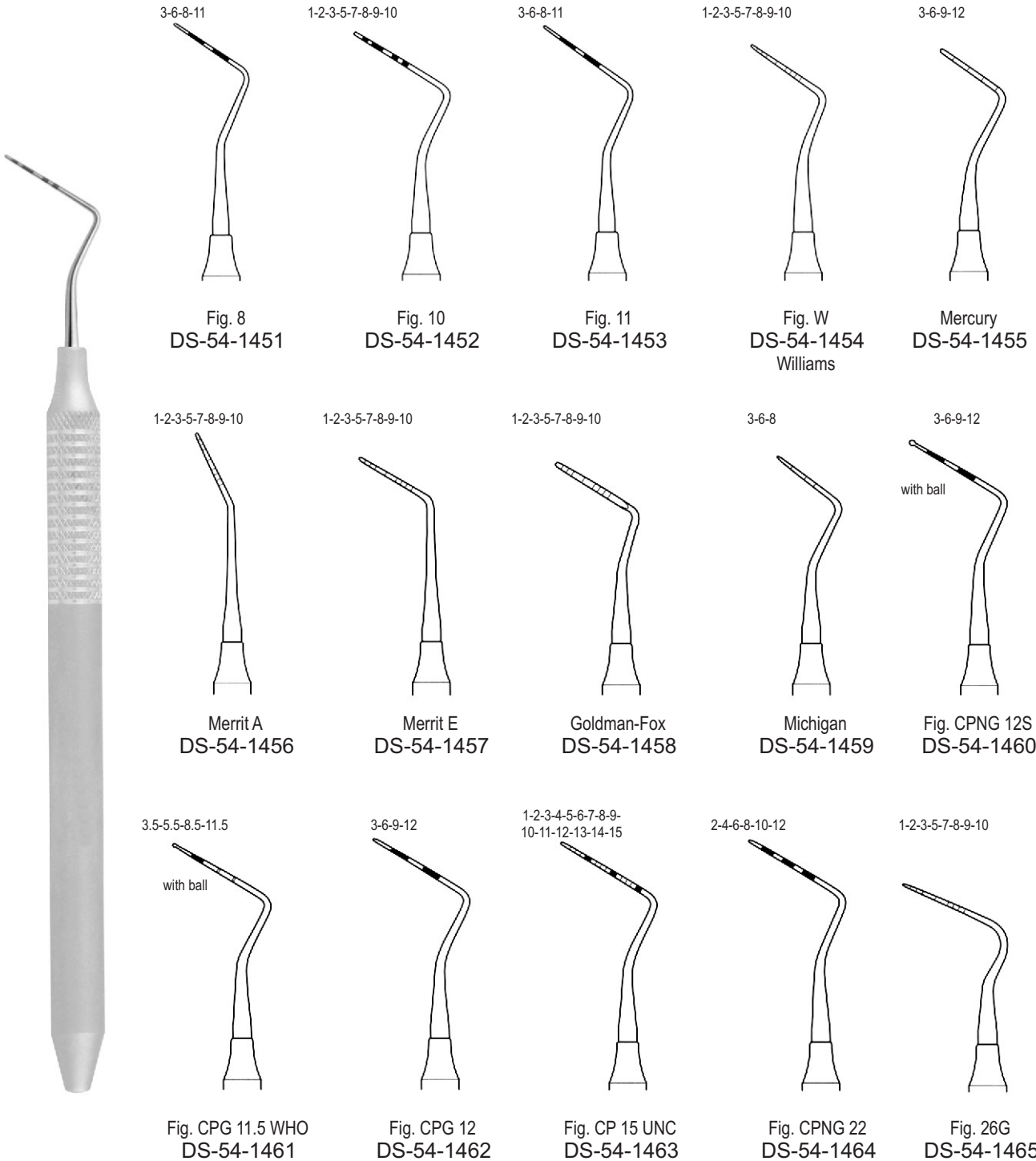

Probes - Single Ended — EN
 Sonden - Single Ended — DE
 Sondas - terminación simple — ES



1-2-3-5-7-8-9-10
FLAT



Goldman-Fox
Williams
DS-54-1466

10-9-8-7-5-3-2-1

3-6-9-12

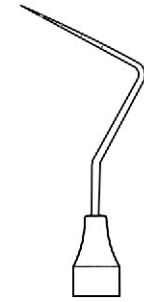

Fig. UT 3/4
Cattoni
DS-54-1467



12-9-6-3

1-2-3-5-7-8-9-10
FLAT

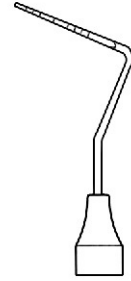
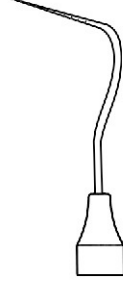

Fig. 3N
Nabers
DS-54-1468



10-9-8-7-5-3-2-1

1-2-3-5-7-8-9-10



Williams DE
Offset
DS-54-1469



10-9-8-7-5-3-2-1

3-6-9-12

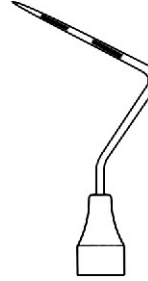
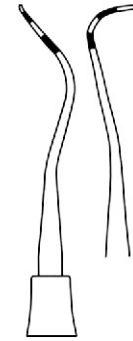

Fig. CP 12/Thin
Williams
DS-54-1470



10-9-8-7-5-3-2-1



Nabers Furcation
probes graduated
working end
DS-54-1471

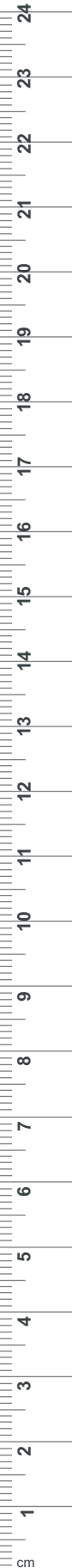

55

- EN** Enamel Instruments
- DE** Emaille-Instrumente
- ES** Instrumentos de esmalte

Page 59 to 62

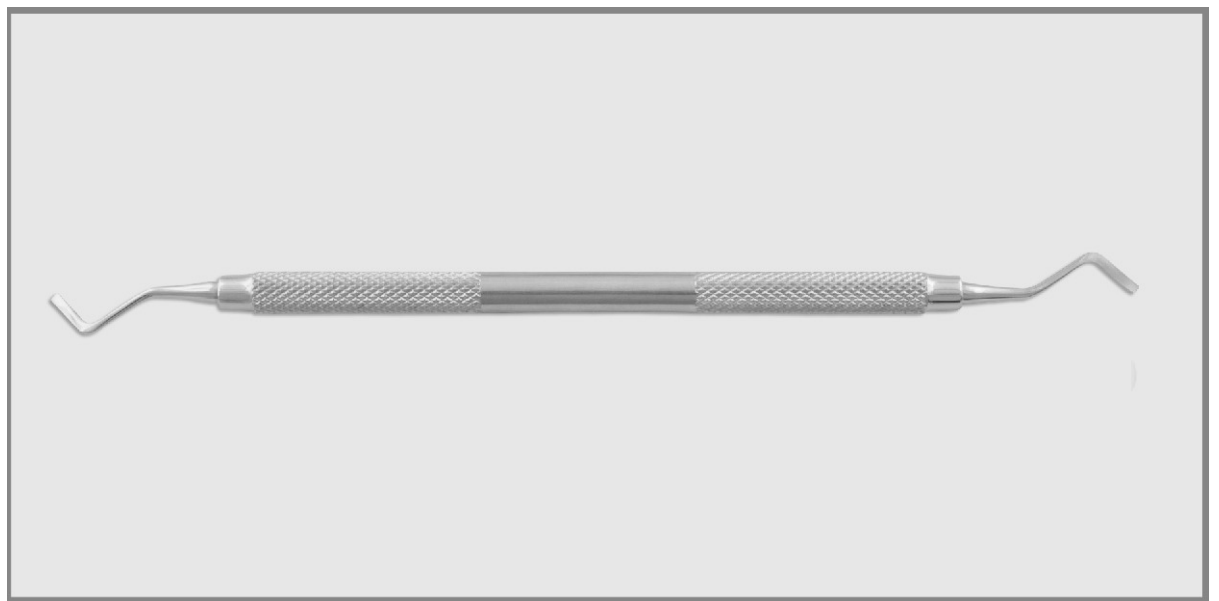

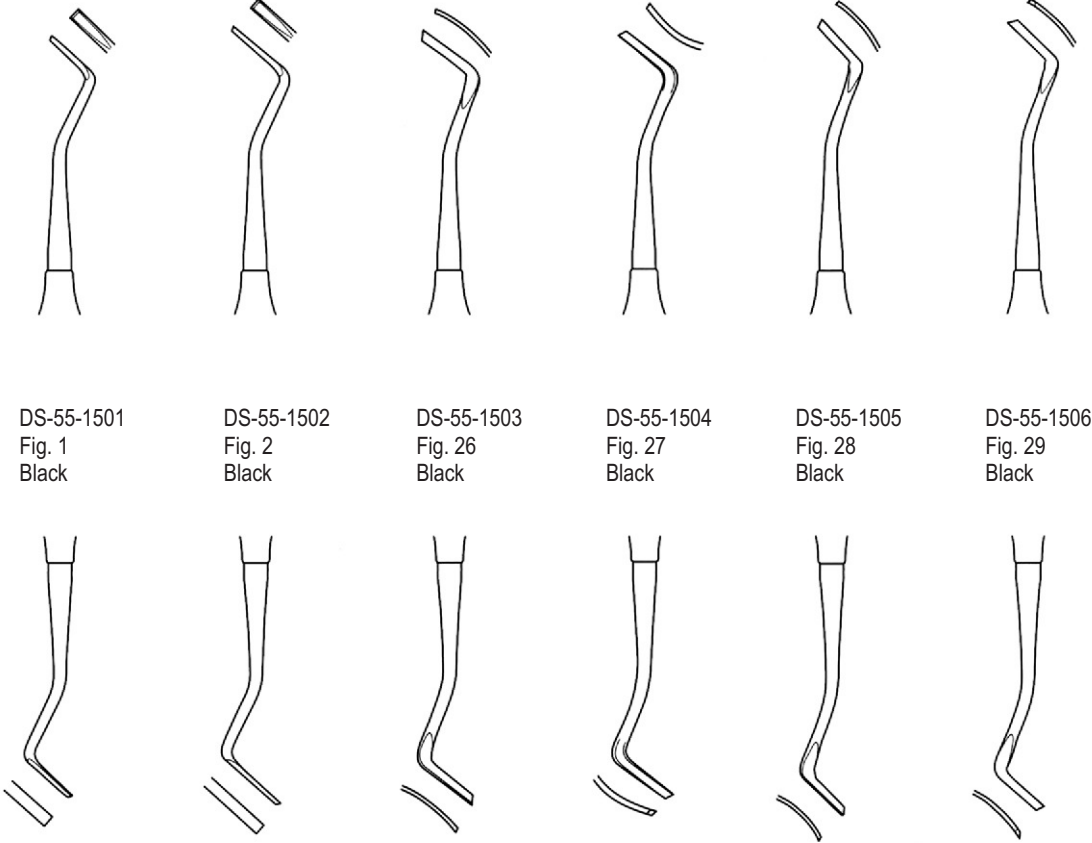

DS-55-1501
Fig. 1
Black

DS-55-1502
Fig. 2
Black

DS-55-1503
Fig. 26
Black

DS-55-1504
Fig. 27
Black

DS-55-1505
Fig. 28
Black

DS-55-1506
Fig. 29
Black



DS-55-1507
 Fig. 51/52
 Black



DS-55-1508
 Fig. 53/54
 Black



DS-55-1509
 Fig. 63/64
 Black



DS-55-1510
 Fig. 65/66
 Black



DS-55-1511
 Fig. 1/2
 Wedelstaedt



DS-55-1512
 Fig. 3/4
 Wedelstaedt



DS-55-1513
 Fig. 5/6
 Wedelstaedt





DS-55-1514
Fig. 8/9H



DS-55-1515
Fig. 13/14



DS-55-1516
Fig. 15/16



DS-55-1517
Fig. 17/18



DS-55-1518
Fig. 51/52



DS-55-1519
Fig. 53/54



DS-55-1520
Fig. 14/14
Off Angle



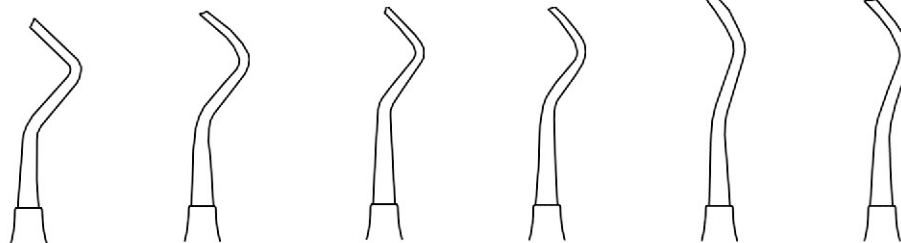

DS-55-1521
 Fig. 26
 Dista

DS-55-1522
 Fig. 27
 Mesial

DS-55-1523
 Fig. 28
 Distal

DS-55-1524
 Fig. 29
 Mesial

DS-55-1525
 Fig. 77/78
 Distal

DS-55-1526
 Mesial
 54-1142-00

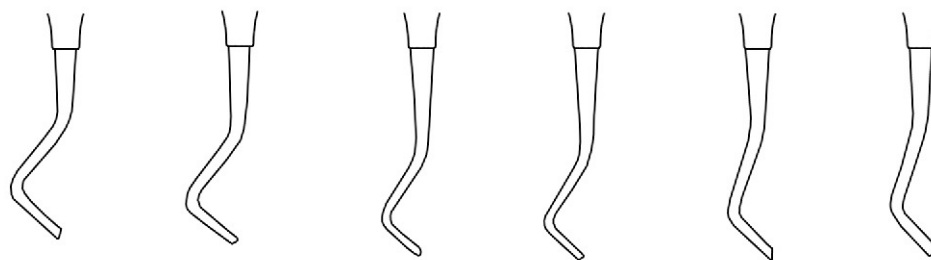

56

- EN** Dental Scalers
- DE** Zahnsteinentferner
- ES** Escaladores dentales

Page 63 to 78

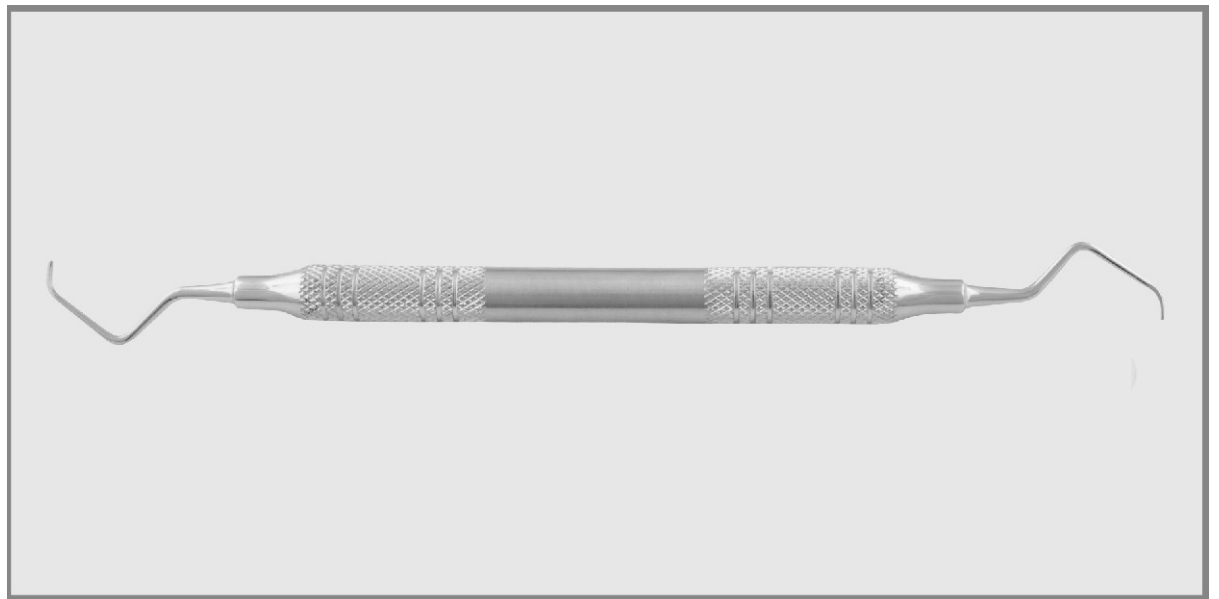



Fig. 3
700-140

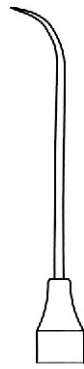

Fig. 3A
DS-56-1551

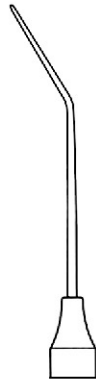

Fig. 5
DS-56-1552



Fig. 6
DS-56-1553
6.5 mm

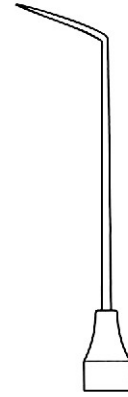

Fig. 6A
DS-56-1554
12 mm

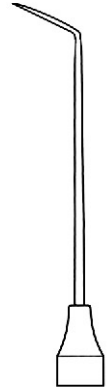

Fig. 6L
DS-56-1555
9 mm



Fig. 6XL
DS-56-1556
12.5 mm

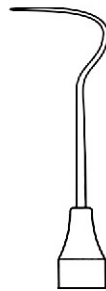

Fig. 8
DS-56-1557



Fig. 8A
DS-56-1558

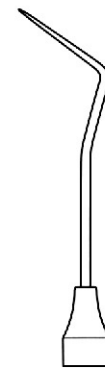

Fig. 9
DS-56-1559



Fig. 10
DS-56-1560

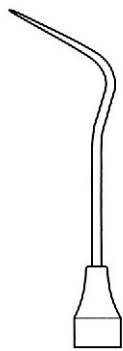

Fig. 12
DS-56-1561



Fig. 17
DS-56-1562



Fig. 17A
DS-56-1563



Fig. 23
DS-56-1564
Shepherd's Hook

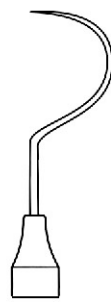

Fig. 54
DS-56-1565

Explorers - Double Ended ● EN
Forscher - Doppelt beendete ● DE
Exploradores - Doble final ● ES



Fig. UT 1/2
DS-56-1566

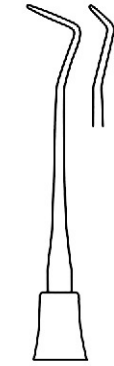

Fig. UT 2/2
DS-56-1567

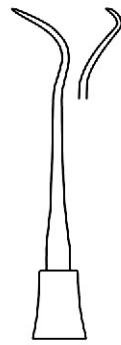

Fig. 3CH/3CH
DS-56-1568



Fig. 6/3
DS-56-1569

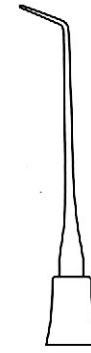

Fig. 16/3
DS-56-1570



Fig. 2
DS-56-1571

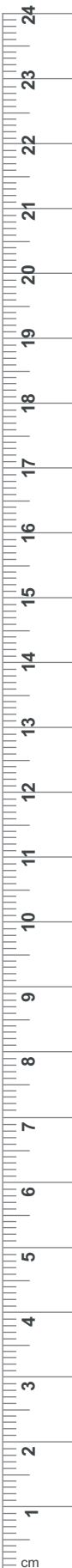
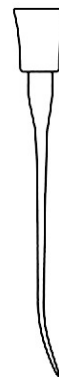
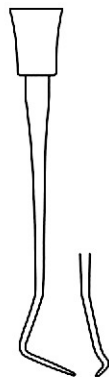



Fig. 23/17
DS-56-1572



Fig. 2A
DS-56-1573



Fig. 3
DS-56-1574

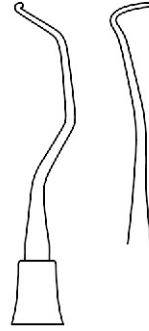

Fig. 1N
DS-56-1575
Nabers



Fig. 2N
DS-56-1576
Nabers

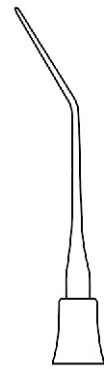
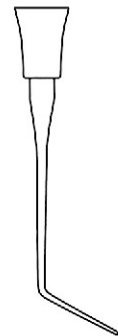

Fig. 5/6
DS-56-1577



Explorers - Double Ended ● — EN
Forscher - Doppelt beendete ● — DE
Exploradores - Doble final ● — ES

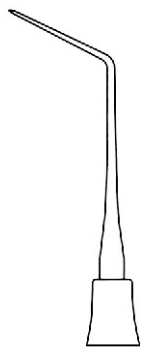

Fig. 16/23
DS-56-1578



Fig. 6/23
DS-56-1579



Fig. 6/17
DS-56-1580



Fig. 23/17A
DS-56-1581



Fig. 3/23
DS-56-1582

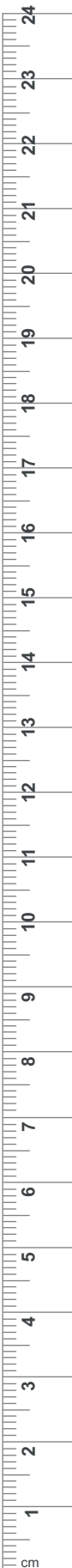



DS-56-1583
Fig. 1/2



DS-56-1584
Fig. 3/4



DS-56-1585
Fig. 5/6



DS-56-1586
Fig. 7/8





DS-56-1587
Fig. 9/10



DS-56-1588
Fig. 11/12



DS-56-1589
Fig. 13/14



DS-56-1590
Fig. 15/16

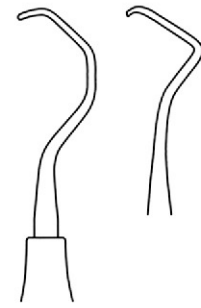

DS-56-1591
Fig. 17/18

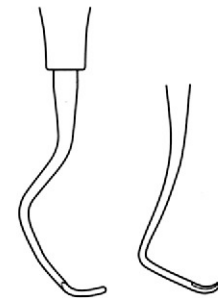



Langer
 DS-56-1592
 Fig. 1/2



Langer
 DS-56-1593
 Fig. 3/4



Langer
 DS-56-1594
 Fig. 5/6



Langer
 DS-56-1595
 Fig. 17/18



Universal curettes are designed for easy adaptation on all tooth surfaces (thus the name "universal").

The blade of a universal curette has a round toe and back, and two cutting edges for scaling, making it an efficient design for scaling the entire mouth.

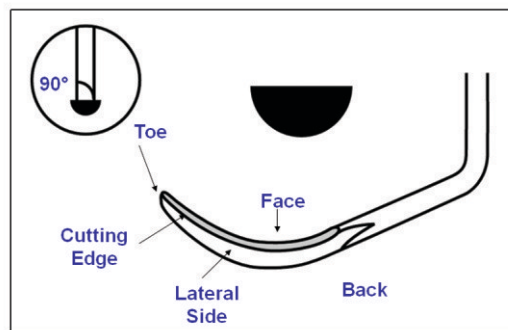



Columbia
 DS-56-1596
 Fig. 13/14



Columbia
 DS-56-1597
 Fig. 2R/2L



Columbia
 DS-56-1598
 Fig. 4R/4L



DS-56-1599
 Fig. Gx4



Barnhart
 DS-56-1600
 Fig. 1/2



Barnhart
 DS-56-1601
 Fig. 5/6

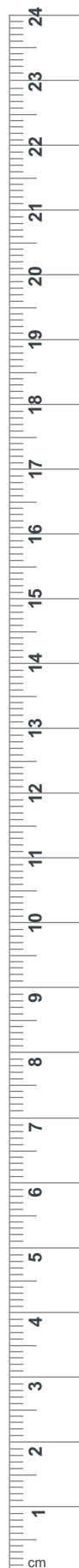



DS-56-1602
Fig. Me1



DS-56-1603
Rule [23-24]
Fig. 3/4



DS-56-1604
Fig. IU 13/14
Indiana University



DS-56-1605
Fig. IU 17/18
Indiana University



DS-56-1606
Fig. 7/8
Younger-Good



DS-56-1607
Fig. 1/2
Bunting



DS-56-1608
Fig. 5/6
Bunting

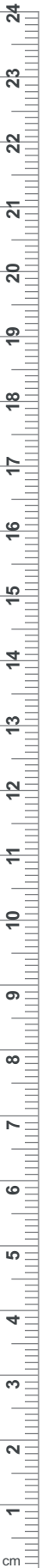



DS-56-1609
 Fig. 1
 Furcation curette



DS-56-1610
 Fig. 2
 Furcation curette



DS-56-1611
 Fig. 3
 Furcation curette



DS-56-1612
 Fig. 4
 Furcation curette

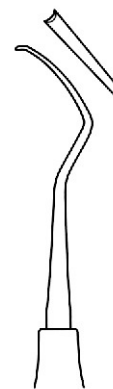

DS-56-1613
 Fig. 5
 Furcation curette



DS-56-1614
 Fig. 1/2
 Prichard





DS-56-1615
Goldman-Fox
Fig. 1

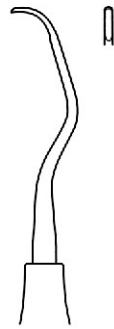

DS-56-1616
Goldman-Fox
Fig. 2



DS-56-1617
Goldman-Fox
Fig. 3



DS-56-1618
Goldman-Fox
Fig. 4



DS-56-1619
Goldman-Fox
Fig. 5



DS-56-1620
Goldman-Fox
Fig. 6



DS-56-1621
Goldman-Fox
Fig. 21



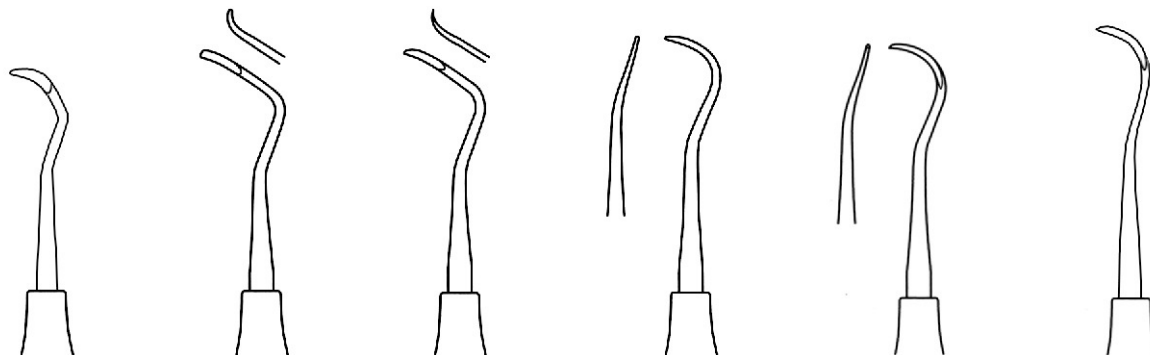

DS-56-1622
 McCall
 Fig. 11/12

DS-56-1623
 McCall
 Fig. 13S/14S

DS-56-1624
 McCall
 Fig. 13SM/14

DS-56-1625
 McCall
 Fig. 17/18

DS-56-1626
 McCall
 Fig. 17S/18S

DS-56-1627
 McCall
 Fig. 19/20

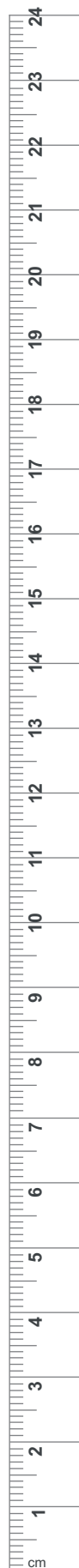
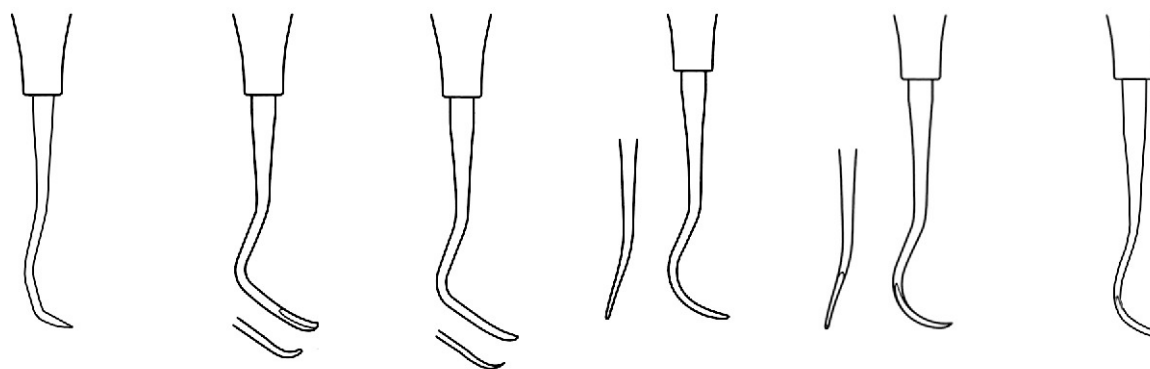

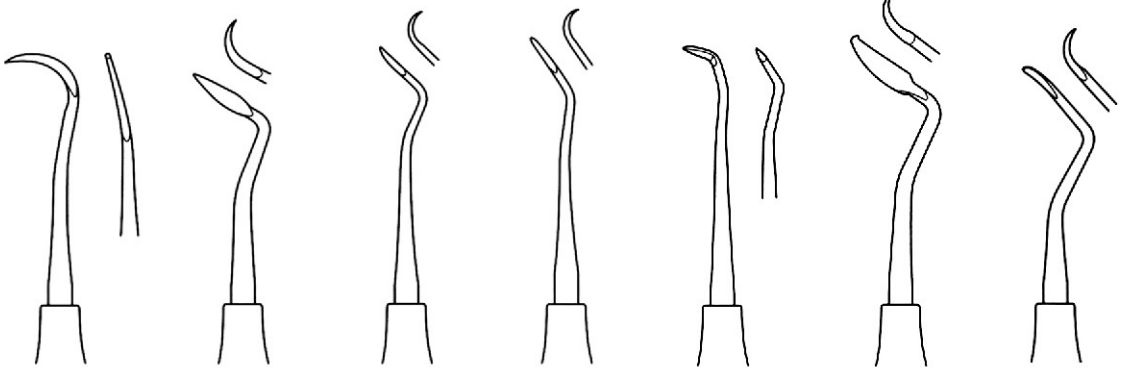

DS-56-1628
Hygienist
Fig. H6/H7

DS-56-1629
Fig. 204

DS-56-1630
Fig. 204 S

DS-56-1631
Fig. 204 SD

DS-56-1632
Zürich

DS-56-1633
Fig. CC 6

DS-56-1634
Fig. M 23

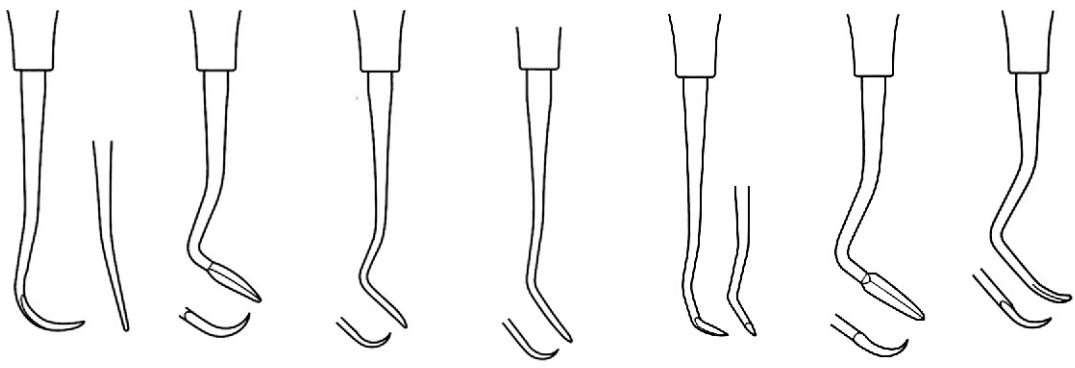

Sickle Scaler — EN
 Sichel-Scaler — DE
 Escalador de hoz — ES



DS-56-1635
 Hygienist-Towner
 Fig. H5/33

DS-56-1636
 Towner
 Fig. U15/30

DS-56-1637
 Towner
 Fig. U15/33

DS-56-1638
 Hygienist-Towner
 Fig. H5/U15

DS-56-1639
 Fig. U 135

DS-56-1640
 Fig. CI 2/3

DS-56-1641
 Taylor
 Fig. T2/T3

DS-56-1642
 Younger-Good
 Fig. 33/34

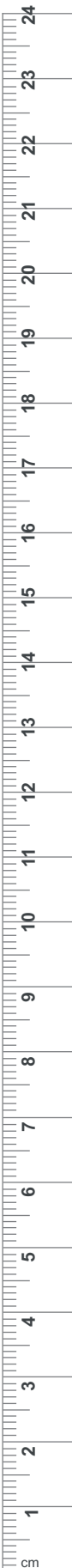

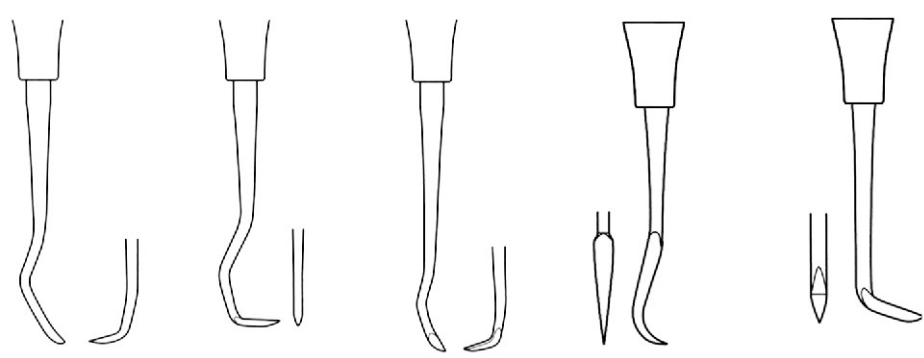
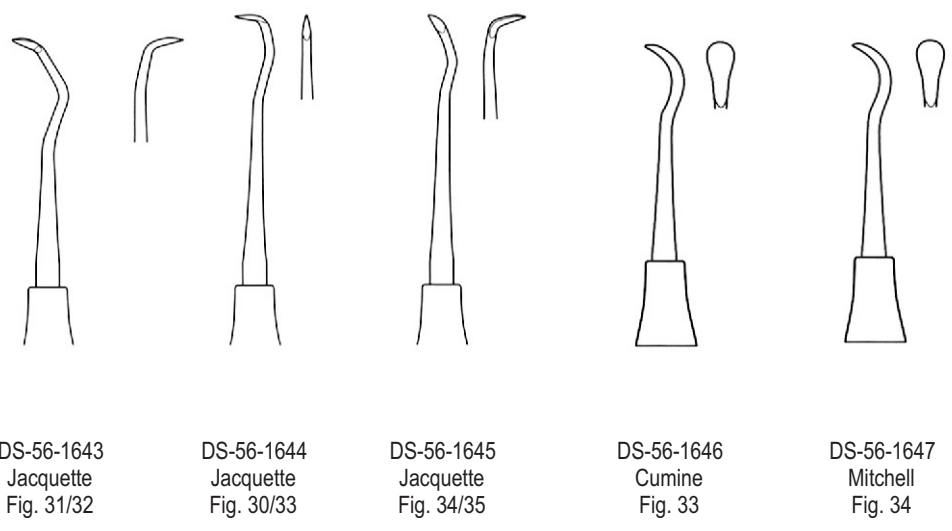

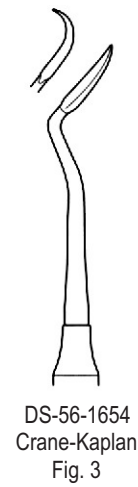
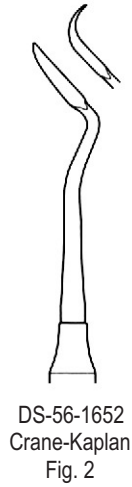
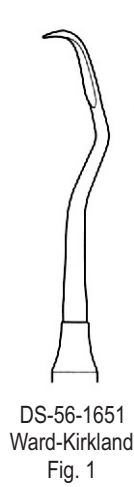
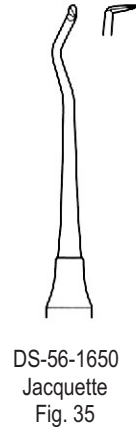
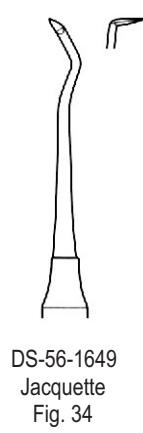
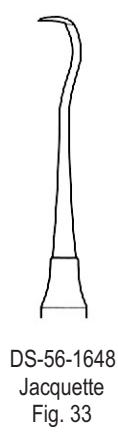

57

EN

Bone Curettes

DE

Knochenküretten

ES

Curetas de hueso

Page 79 to 84

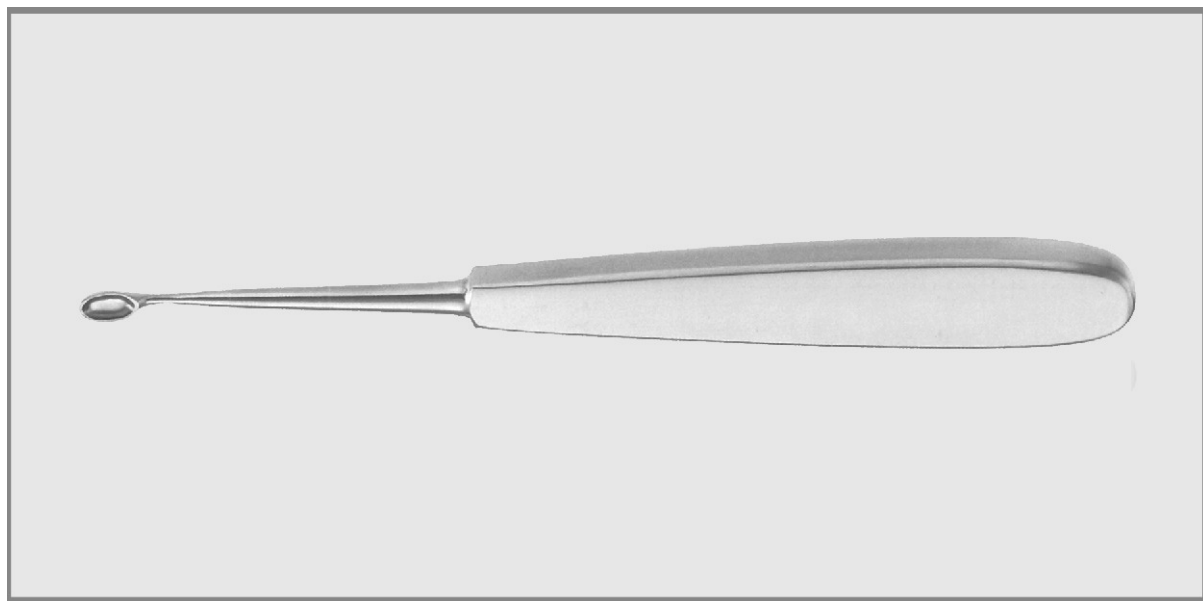

DS-57-1701
DS-57-1702

DS-57-1703
DS-57-1704



WILLIGER



Fig. 00
Fig. 0
Fig. 1
Fig. 2

DS-57-1705 DS-57-1709
DS-57-1706 DS-57-1710
DS-57-1707 DS-57-1711
DS-57-1708 DS-57-1712

DS-57-1713 DS-57-1717
DS-57-1714 DS-57-1718
DS-57-1715 DS-57-1719
DS-57-1716 DS-57-1720



Mod. USA

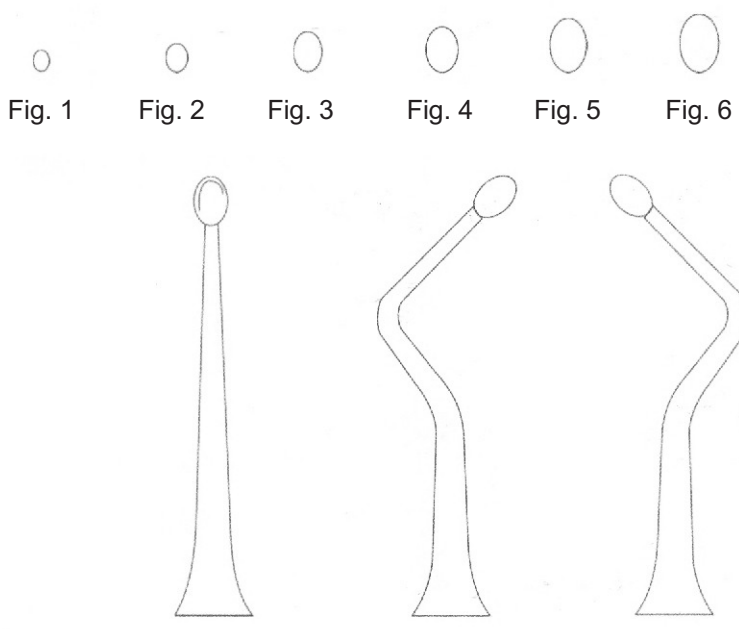

Fig. 1	DS-57-1721	R	DS-57-1727	L	DS-57-1733
Fig. 2	DS-57-1722		DS-57-1728		DS-57-1734
Fig. 3	DS-57-1723		DS-57-1729		DS-57-1735
Fig. 4	DS-57-1724		DS-57-1730		DS-57-1736
Fig. 5	DS-57-1725		DS-57-1731		DS-57-1737
Fig. 6	DS-57-1726		DS-57-1732		DS-57-1738



DS-57-1740 R
 DS-57-1741 L

CHOMPRET
 DS-57-1739





DS-57-1748- DS-57-1750R-
 DS-57-1749 DS-57-1751R



WILLGER

DS-57-1742
 Fig. 00/00

DS-57-1743
 Fig. 0/0

DS-57-1744
 Fig. 1/1



MARTINI

DS-57-1745
 Fig. 00/00

DS-57-1746
 Fig. 0/0

DS-57-1747
 Fig. 1/1

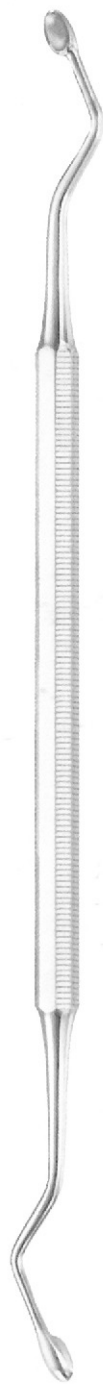

HEMINGWAY
 18 CM/7"

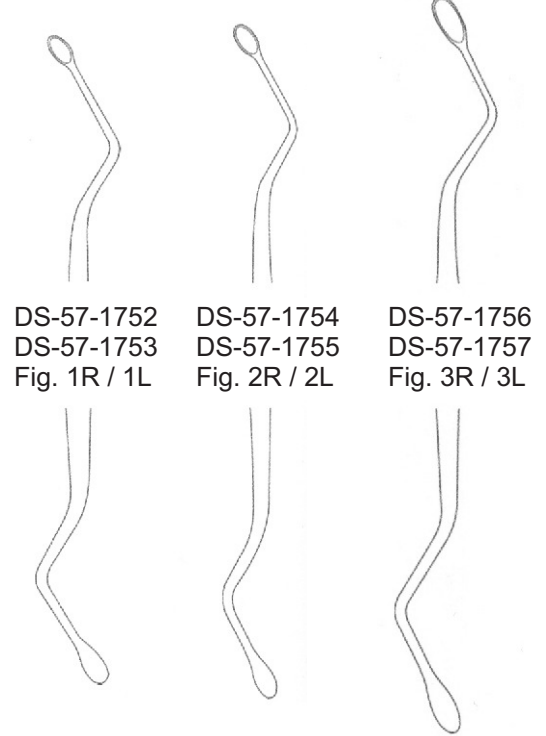

DS-57-1752
 DS-57-1753
 Fig. 1R / 1L

DS-57-1754
 DS-57-1755
 Fig. 2R / 2L

DS-57-1756
 DS-57-1757
 Fig. 3R / 3L

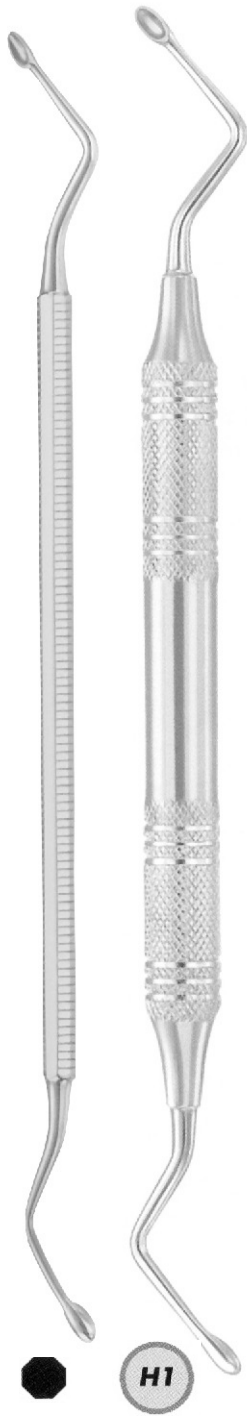

5,5 mm Ø9,5 mm
 HEMINGWAY
 17 cm/6 3/4"

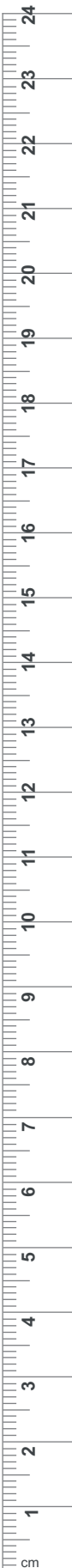
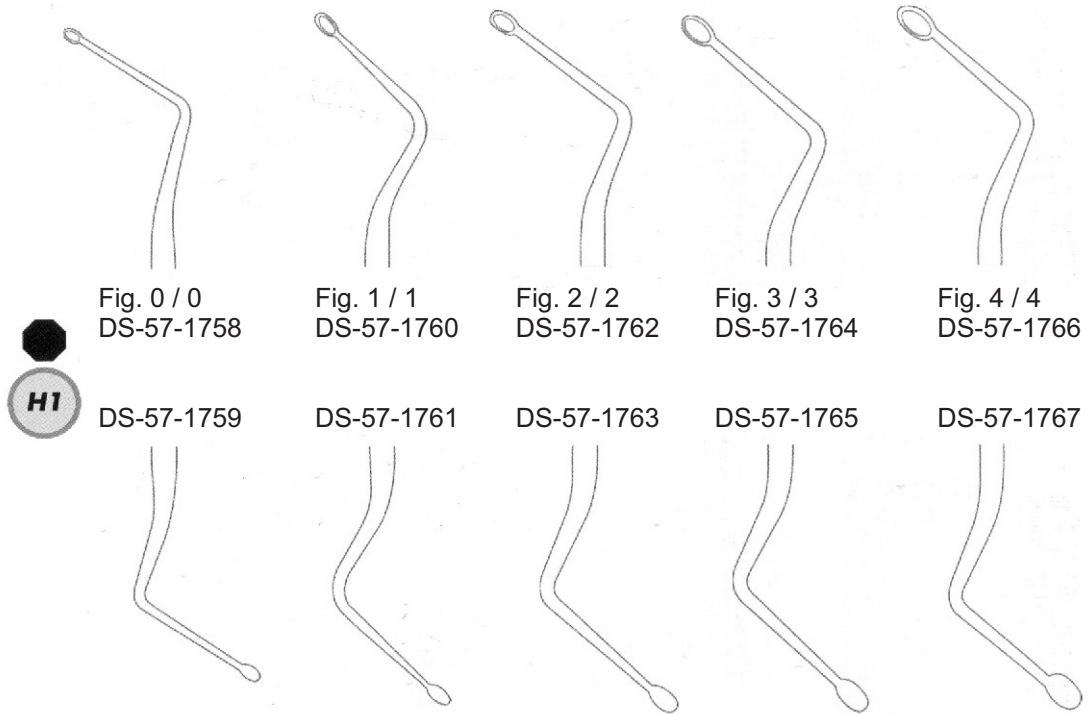

DS-57-1768 DS-57-1770
DS-57-1769 DS-57-1771

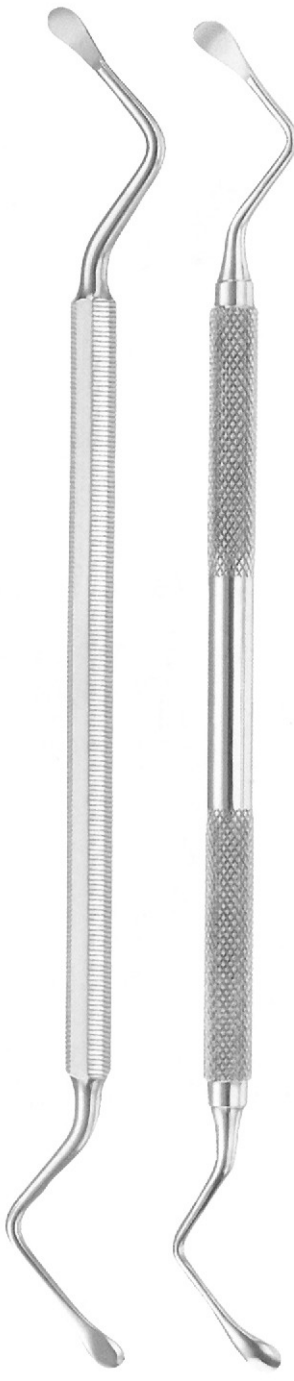

LUCAS
17 cm/6¾"

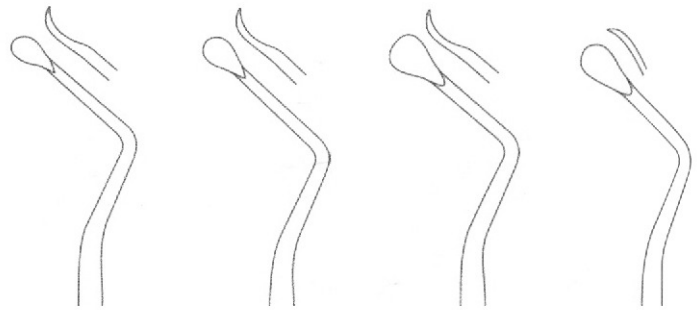

DS-57-1772 DS-57-1774 DS-57-1776 DS-57-1778
DS-57-1773 DS-57-1775 DS-57-1777 DS-57-1779
Fig. 1 / 1 Fig. 2 / 2 Fig. 3 / 3 Fig. 4 / 4

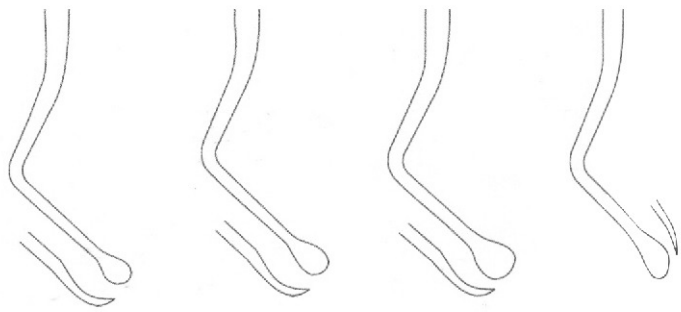



Fig. 4



Fig. 5



Fig. 1



Fig. 2



Fig. 3



Fig. 4

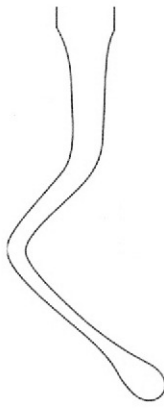

MEAD
 DS-57-1780 DS-57-1781



DS-57-1782

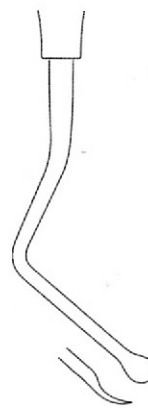

MILLER-COLBURN
 DS-57-1783

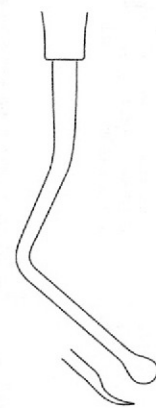

DS-57-1784

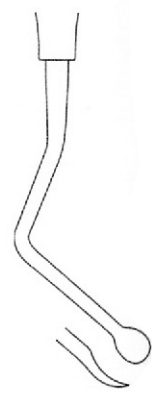

DS-57-1785



58

- EN** Excavators
- DE** Bagger
- ES** Excavadoras

Page 85 to 89





DS-58-1800
Fig.72/73

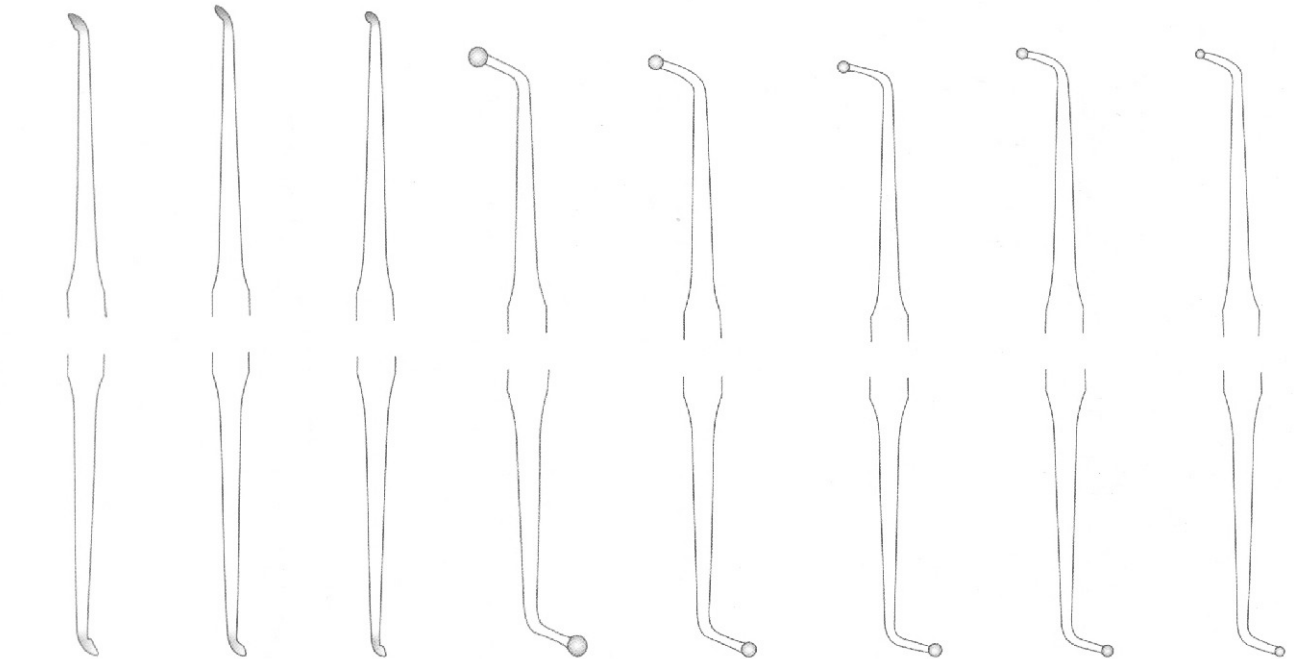

DS-58-1801 Fig. 73/74 DS-58-1802 Fig. 74/111 DS-58-1803 Fig. 111/112 DS-58-1804 Fig. 113/114 DS-58-1805 Fig. 115/116 DS-58-1806 Fig. 117/118 DS-58-1807 Fig. 119/120 DS-58-1808 Fig. 1121/122

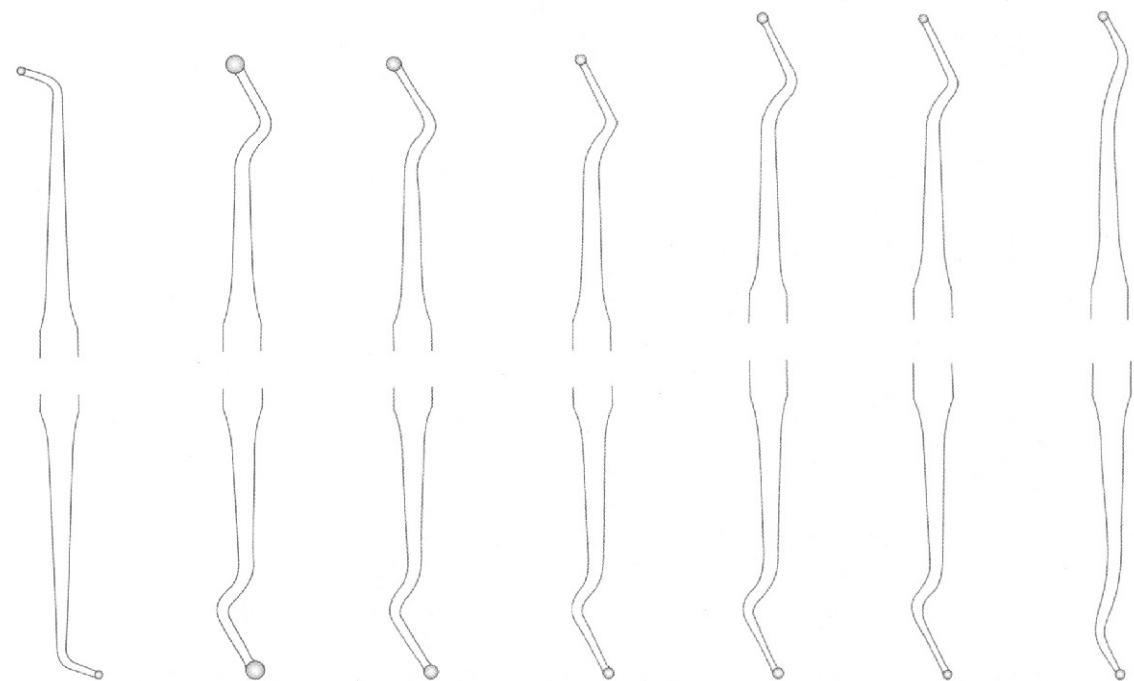

DS-58-1809 Fig.123/124 DS-58-1810 Fig.125/126 DS-58-1811 Fig.127/128 DS-58-1812 Fig.129/130 DS-58-1813 Fig.131/132 DS-58-1814 Fig.133/134 DS-58-1815 Fig.155/156

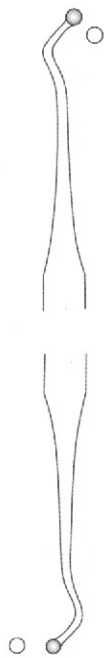

DS-58-1816
 Fig.139/140

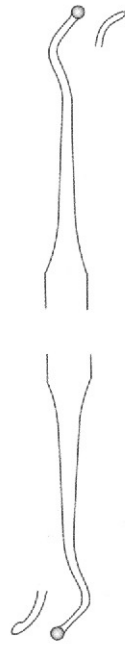

DS-58-1817
 Fig.141/142



DS-58-1818
 Fig.159/160

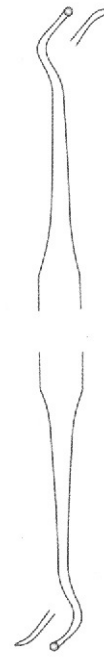

DS-58-1819
 Fig.161/162



DS-58-1820
 Fig.165/166



DS-58-1821
 Fig.171/172



DS-58-1822
 Fig.173/174



DS-58-1823
 Fig.175/176



DS-58-1824
 Fig.177/178



DS-58-1825
 Fig.179/180



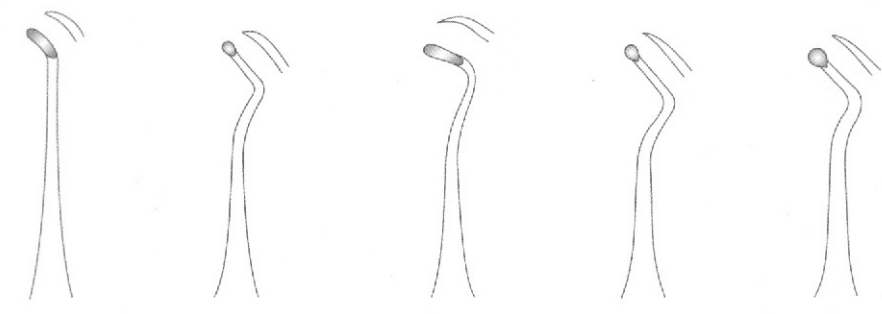

DS-58-1826
Fig. 5

DS-58-1827
Fig. 13

WHITE
DS-58-1828
Fig. 14

DS-58-1829
Fig. 15

DS-58-1830
Fig. 17

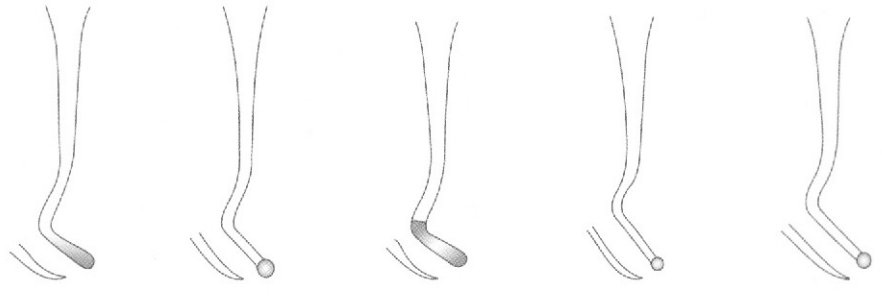
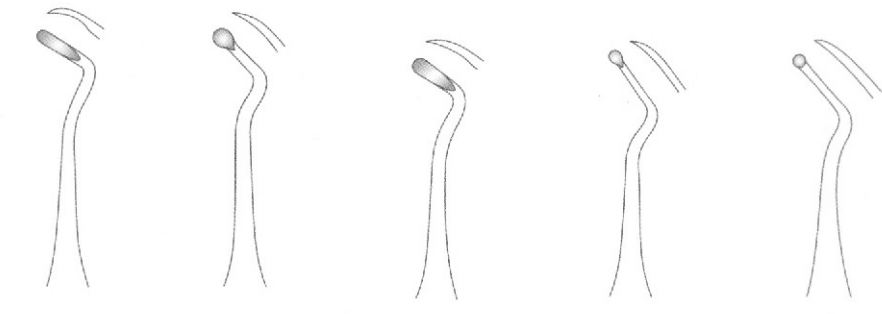
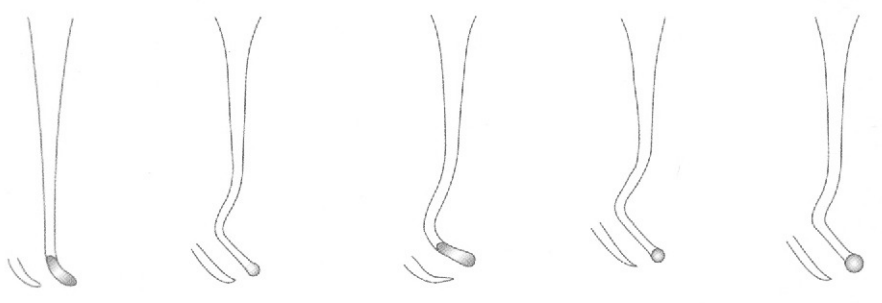

DS-58-1831
Fig. 18

DS-58-1832
Fig. 19

WHITE
DS-58-1833
Fig. 20

DS-58-1834
Fig. 23

DS-58-1835
Fig. 25



Ø6
mm

H1
Ø9,5
mm

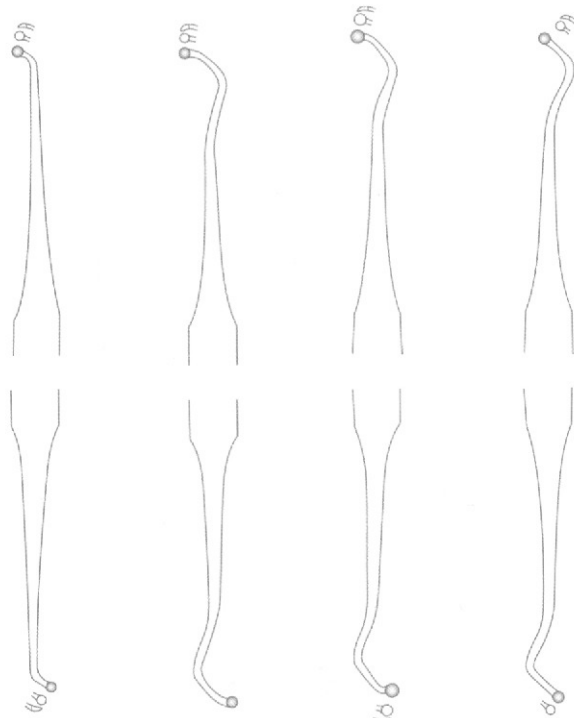

Fig. 5 DS-58-1836 Fig. 13 DS-58-1837 Fig. 14 DS-58-1838 Fig. 17 DS-58-1839

●
H1 DS-58-1840 DS-58-1841 DS-58-1842 DS-58-1843

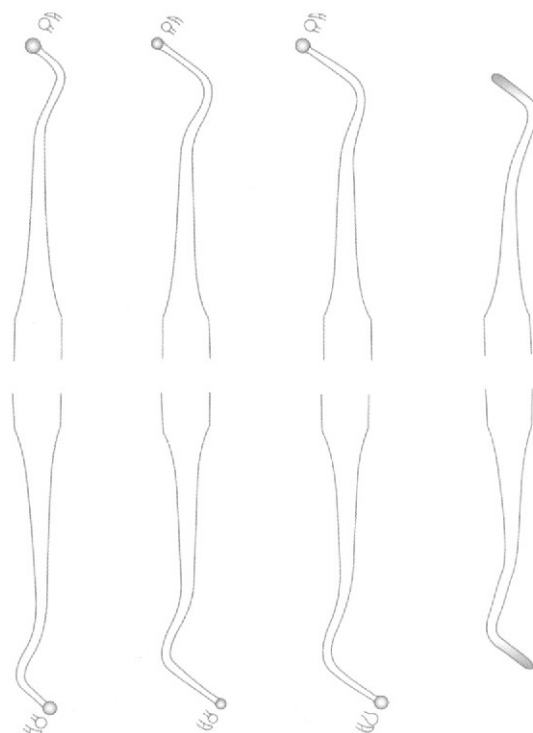
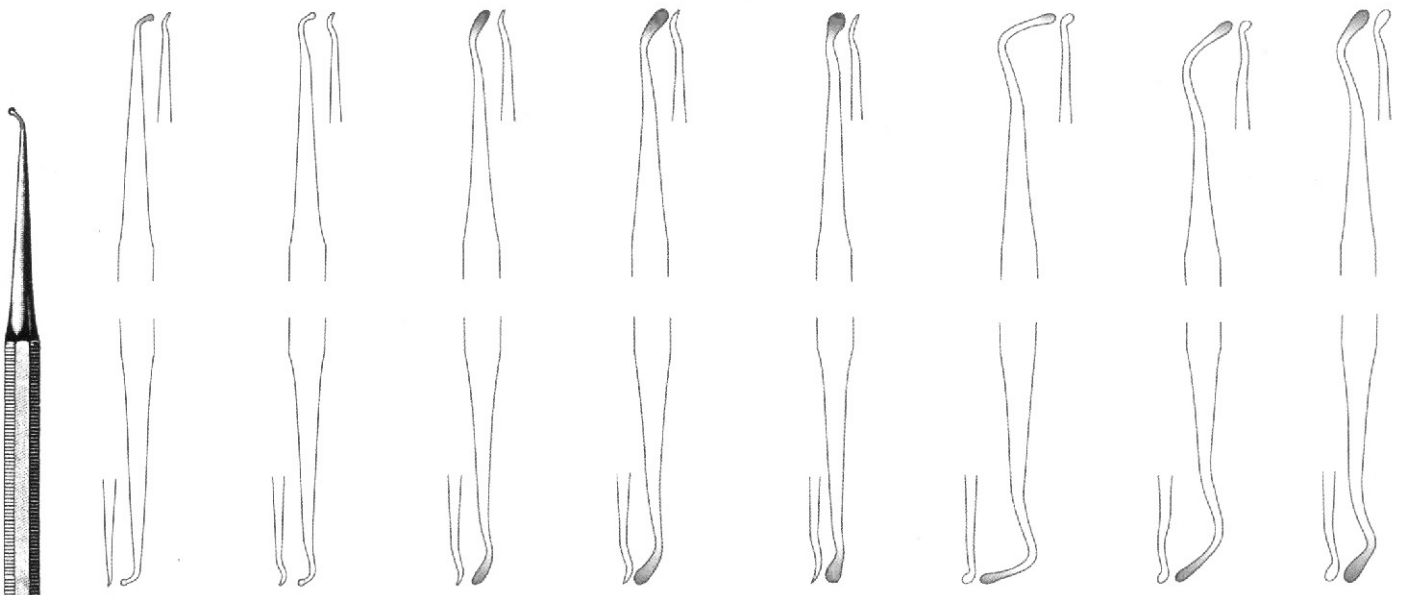

Fig. 18 DS-58-1844 Fig. 31 DS-58-1845 Fig. 33 DS-58-1846 Fig. 35 DS-58-1847

●
H1 DS-58-1848 DS-58-1849 DS-58-1850 DS-58-1851





DARBY-PERRY

DS-58-1853 Fig. 7/8 DS-58-1854 Fig. 9/10 DS-58-1855 Fig. 11/12 DS-58-1856 Fig. 13/14 DS-58-1857 Fig. 15/16 DS-58-1858 Fig. 17/18 DS-58-1859 Fig. 19/20 DS-58-1860 Fig. 21/22

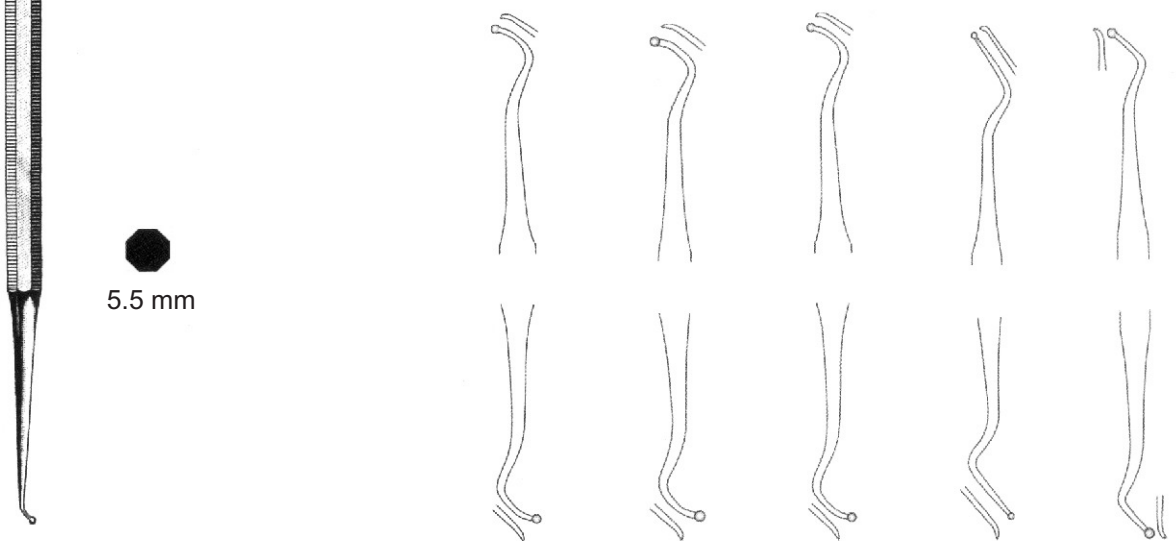

GILLET

DS-58-1861 Fig. 4/5 DS-58-1862 Fig. 6/7 DS-58-1863 Fig. 7/8 DS-58-1864 Fig. 12/13 DS-58-1865 Fig. 14/15

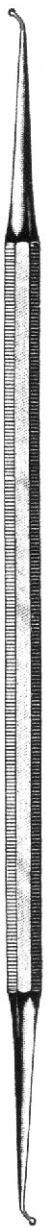

DS-58-1852 Fig. 5/6

59

- EN** Wax Proclein
- DE** Wachs-Porzellan
- ES** cera Porcelana

Page 90 to 94

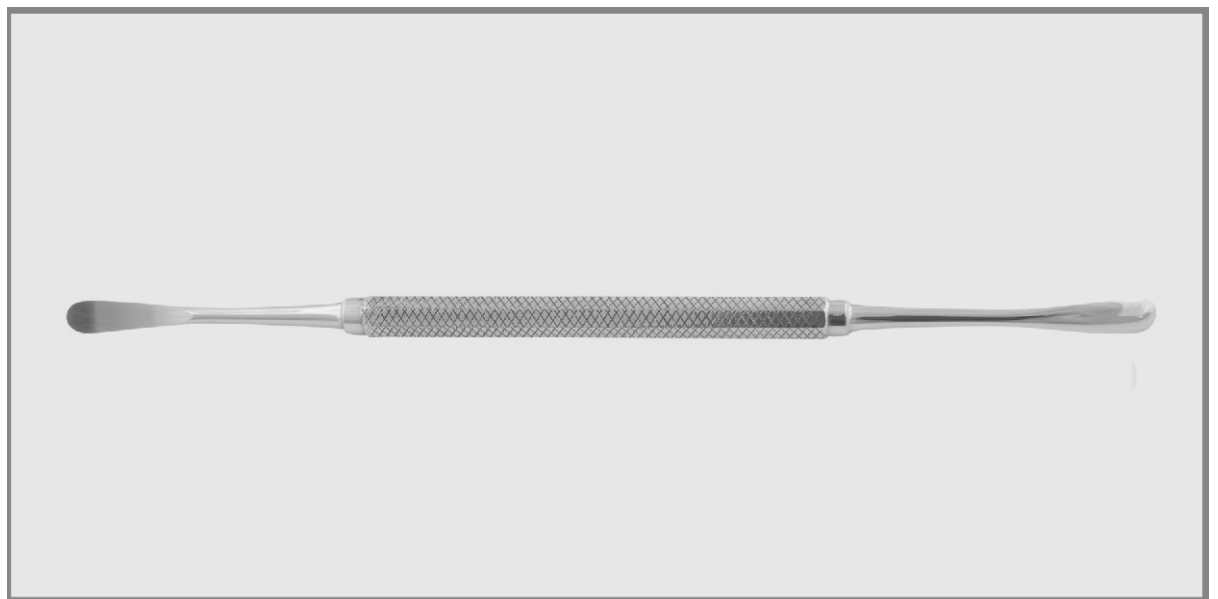

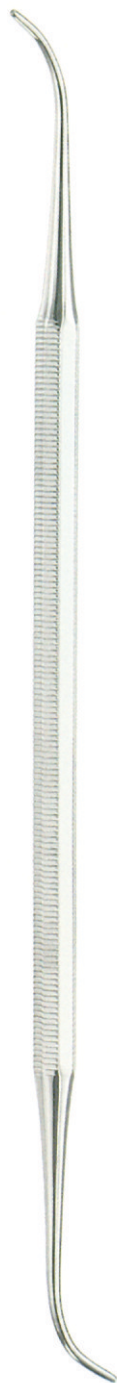

5,5 mm



H1
Ø9,5 mm



DS-59-1901
Fig. 1



DS-59-1902
Fig. 2



DS-59-1903
Fig. 3



DS-59-1904
Fig. 4



DS-59-1905
Fig. 5



DS-59-1906H

DS-59-1907H

DS-59-1908H

DS-59-1909H

DS-59-1910H

Aluminium

DS-59-1911

DS-59-1912

DS-59-1913

DS-59-1914

DS-59-1915

gold

green

blue

red

silver

MODELLING



GRITMAN
 DS-59-1916

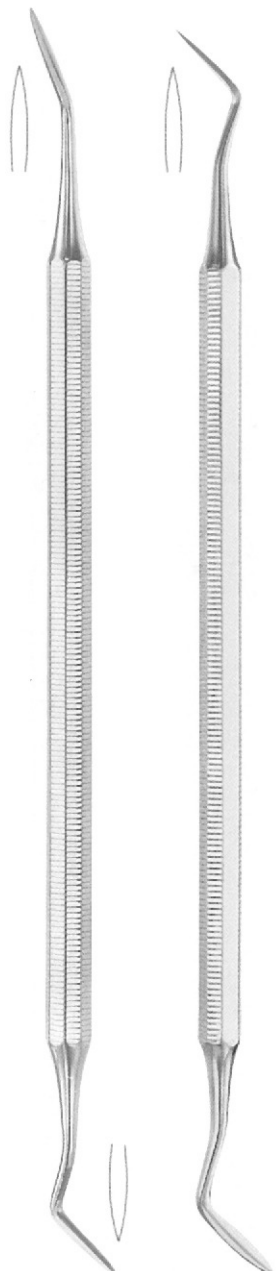

WARD
 DS-59-1917 Fig. 1
 DS-59-1918 Fig. 2

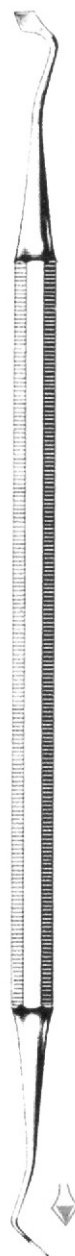

FRAHM
 DS-59-1919



SHOSHAN
 DS-59-1920
 SHO-A



W.A.C.D
 DS-59-1921

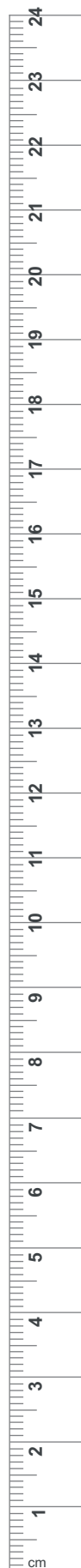

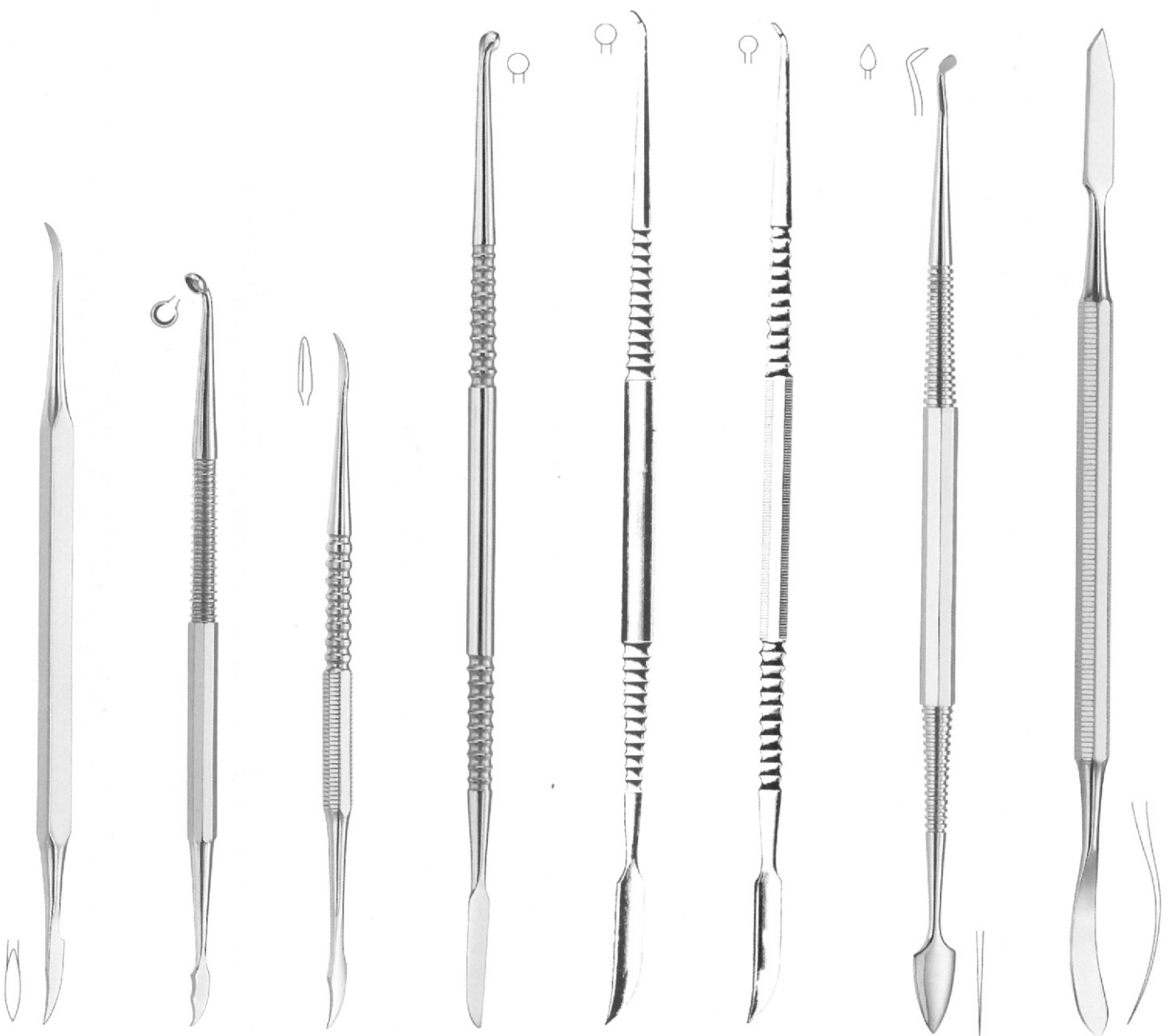

HYLIN DS-59-1922 ZAHLE DS-59-1923 DS-59-1924 LE CRON DS-59-1925 DS-59-1926 DS-59-1927 VEHE DS-59-1928 FIELDSTAD DS-59-1929



ROACH
 DS-59-1930 DS-59-1931

RIEGNER
 DS-59-1932

DS-59-1933
 Fig. 1

DS-59-1934
 Fig. 2

FRAHM
 DS-59-1935
 Fig. 6

DS-59-1936
 Fig. 10

DS-59-1937
 Fig. 6/10

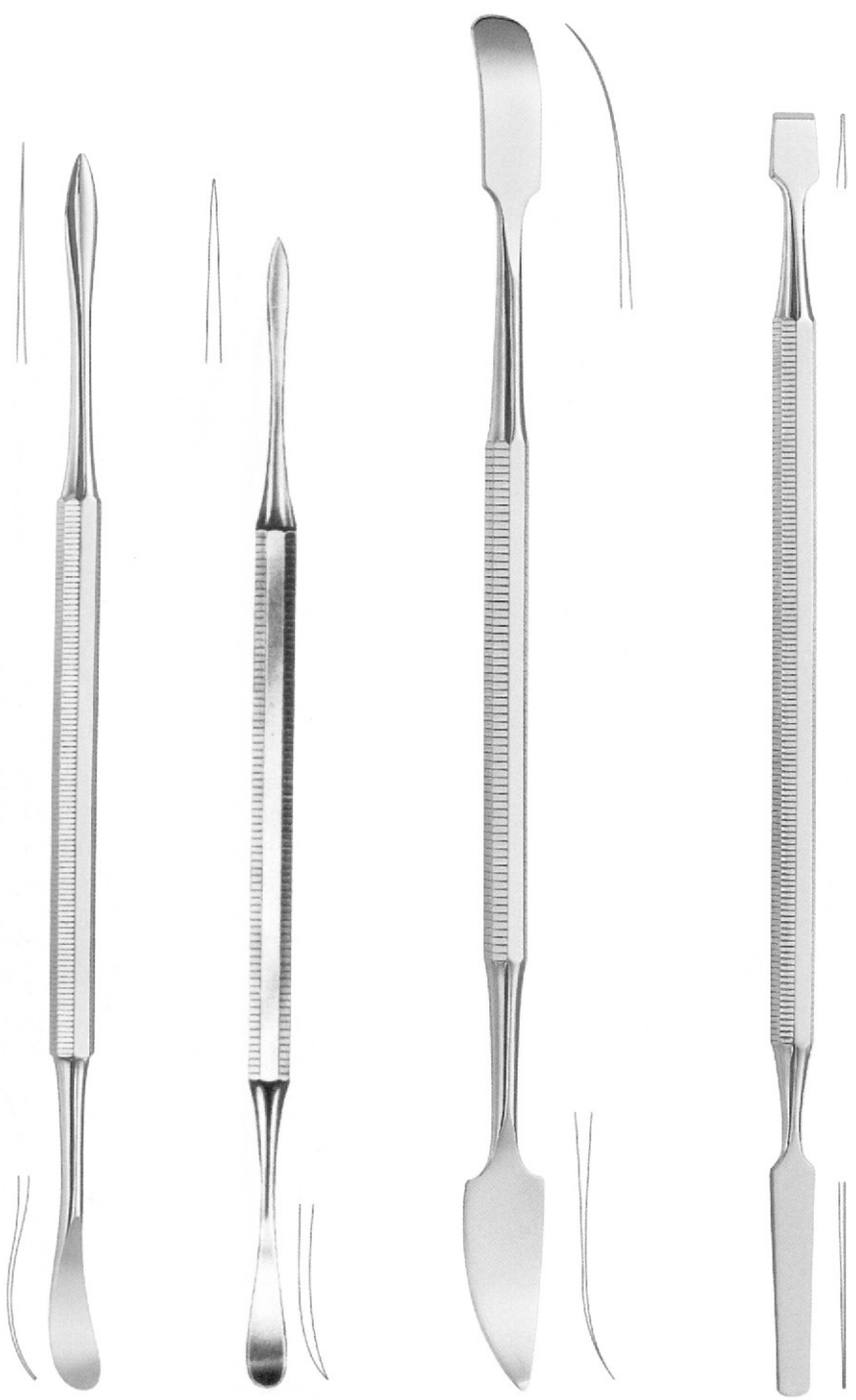

BEALE
 DS-59-1938 DS-59-1939
 Fig. 7A

GRITMAN
 DS-59-1940
 19,5 cm/7 3/4"

WESTON
 DS-59-1941

60

- EN** Filling Instruments
- DE** Füllungsinstrumente
- ES** Actos de llenado

Page 95 to 105



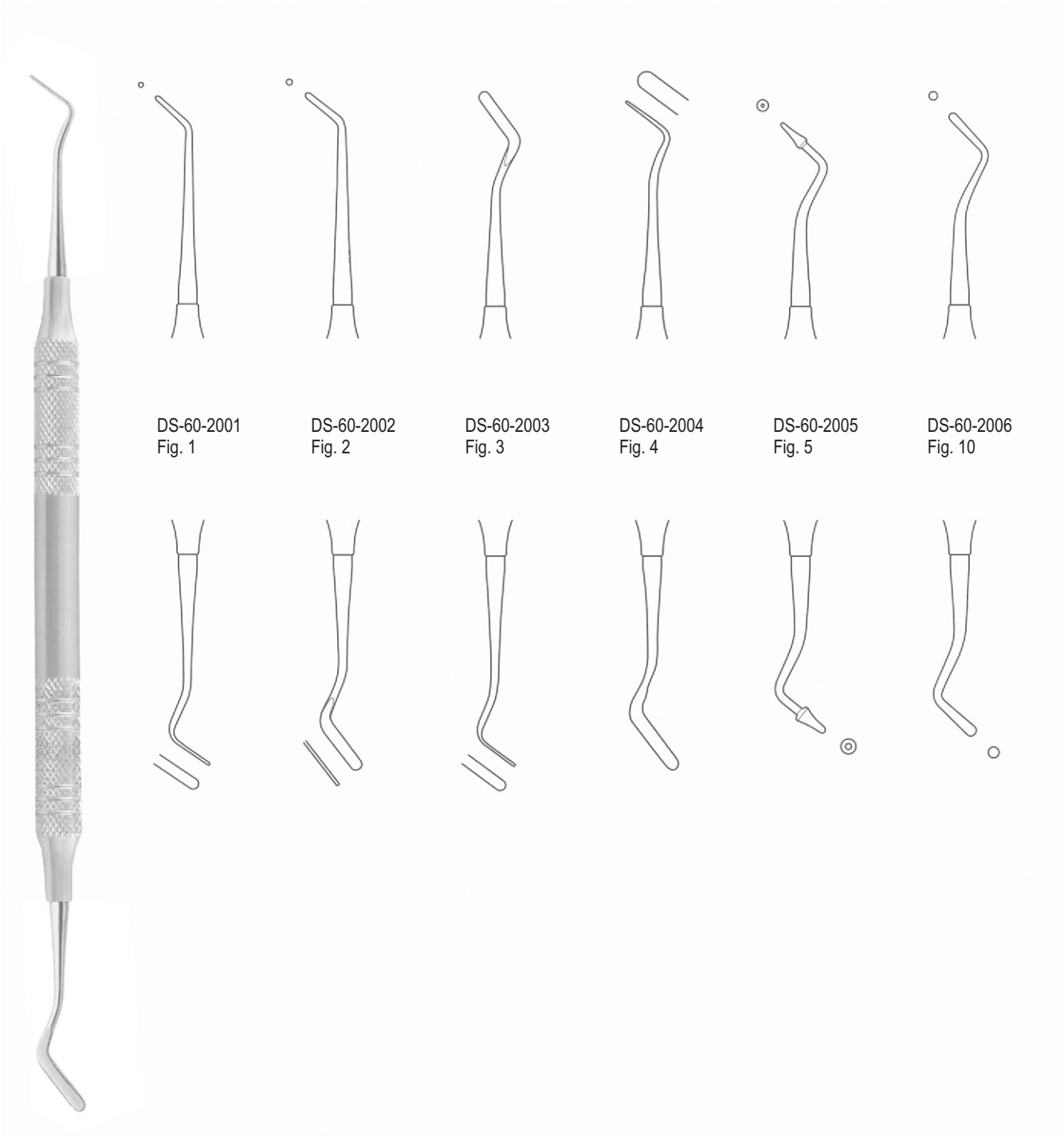

DS-60-2001
Fig. 1

DS-60-2002
Fig. 2

DS-60-2003
Fig. 3

DS-60-2004
Fig. 4

DS-60-2005
Fig. 5

DS-60-2006
Fig. 10

Note: Titanium Coated Points are available on customer demand.

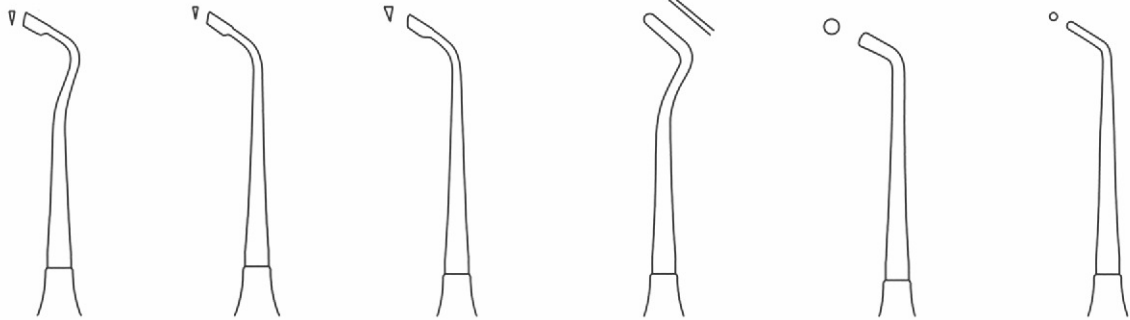

DS-60-2007
Fig. 1
Felt

DS-60-2008
Fig. 2
Felt

DS-60-2009
Fig. 3
Felt

DS-60-2010
Fig. 4
Felt

DS-60-2011
Fig. 5
Felt

DS-60-2012
Fig. 6
Felt

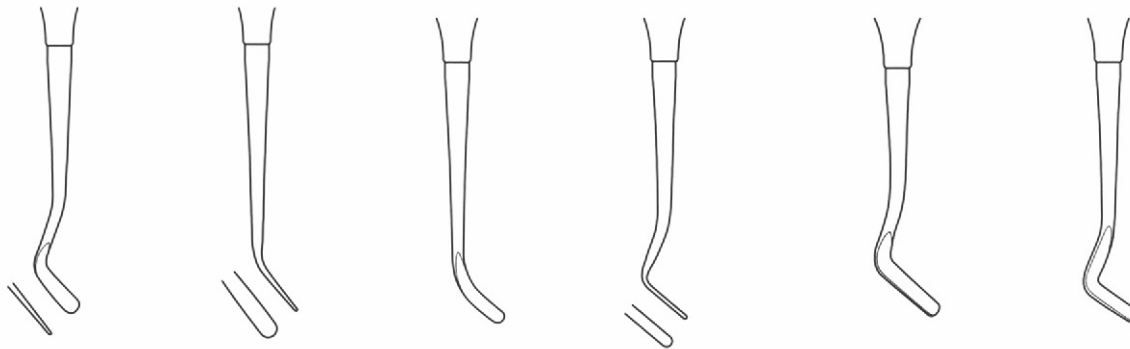

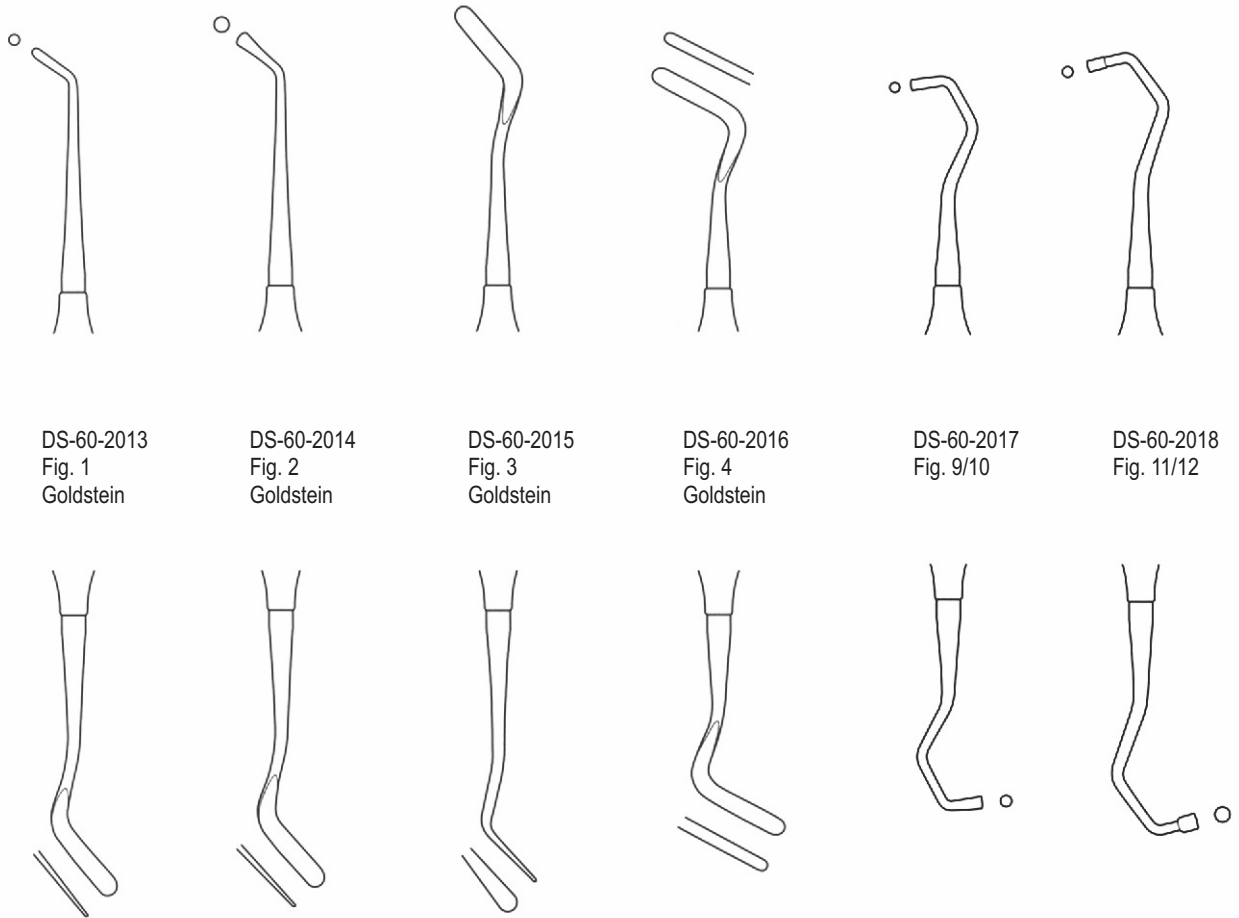
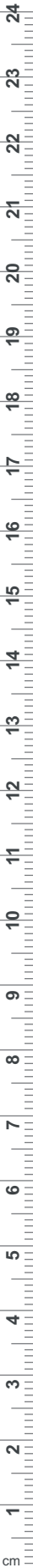

DS-60-2013
Fig. 1
Goldstein

DS-60-2014
Fig. 2
Goldstein

DS-60-2015
Fig. 3
Goldstein

DS-60-2016
Fig. 4
Goldstein

DS-60-2017
Fig. 9/10

DS-60-2018
Fig. 11/12

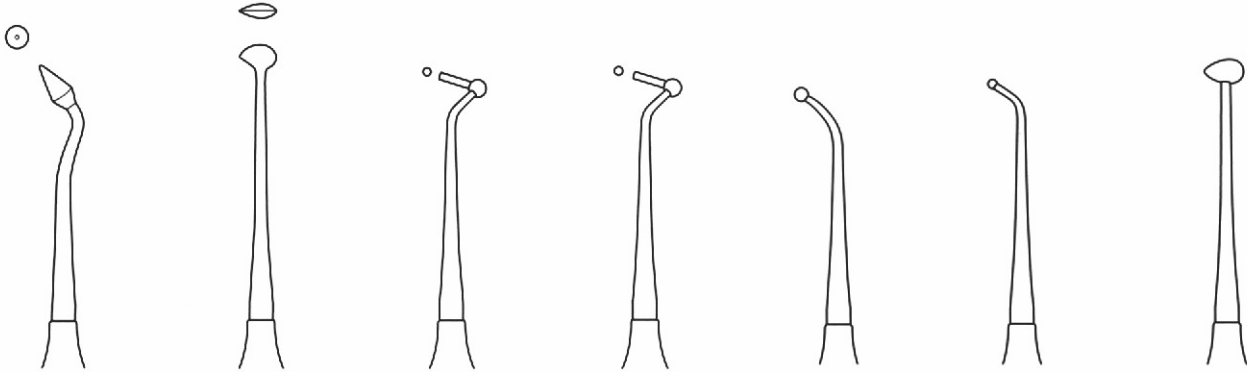

DS-60-2019
Fig. SB

DS-60-2020
Fig. 29/2B

DS-60-2021
Fig. L1
Loesche

DS-60-2022
Fig. L2
Loesche

DS-60-2023
Fig. 18
Ball Burnisher

DS-60-2024
Fig. 26/27S
Ball Burnisher

DS-60-2025
Fig. 28/29
Ball Burnisher

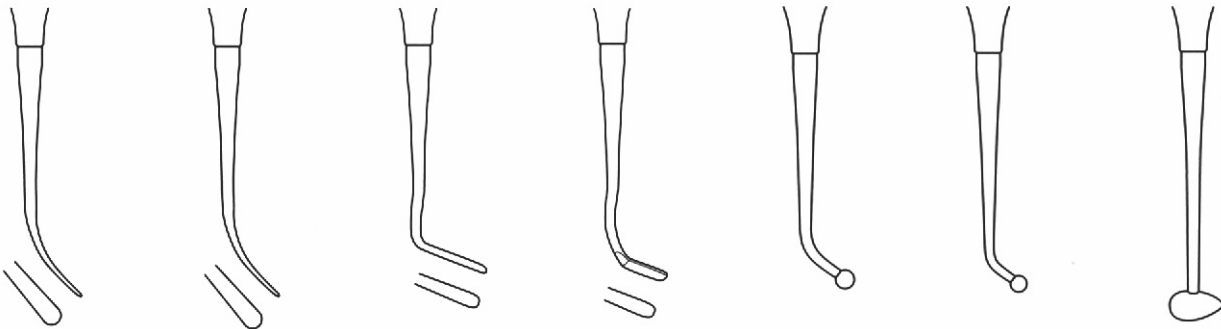



DS-60-2026
Fig. 1S



DS-60-2027
Fig. 2S



DS-60-2028
Fig. 3S



DS-60-2029
Fig. 4S



DS-60-2030
Fig. 1P



DS-60-2031
Fig. 2P



DS-60-2032
Fig. 3P



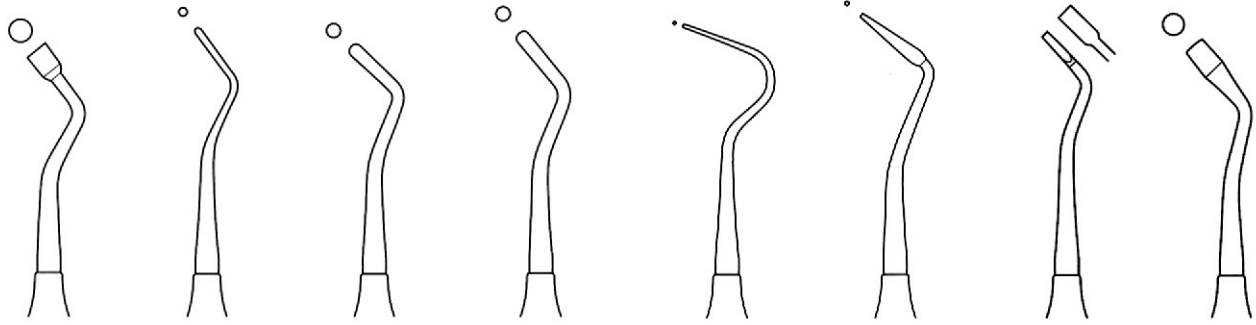

DS-60-2033 Fig. 4P DS-60-2034 Fig. 1D DS-60-2035 Fig. 2D DS-60-2036 Fig. 3D DS-60-2037 Fig. M1 Markley DS-60-2038 Fig. M2 DS-60-2039 Fig. M3 DS-60-2040 Fig. M4

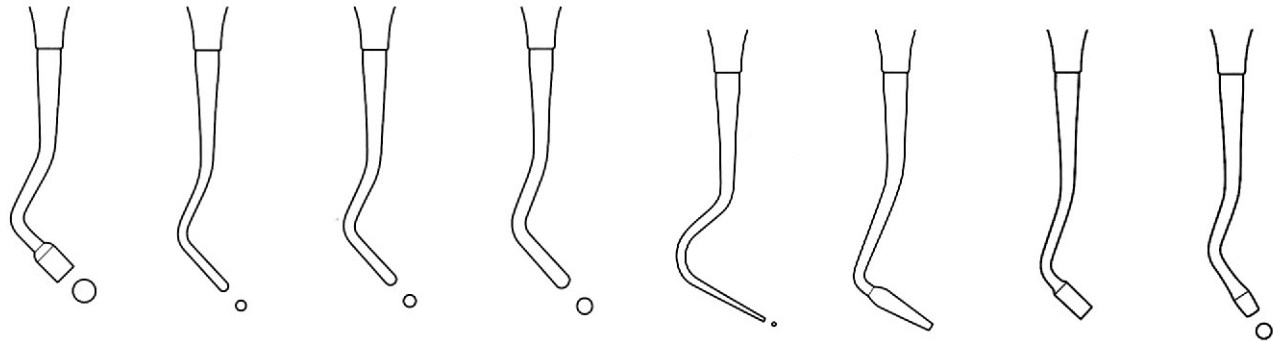

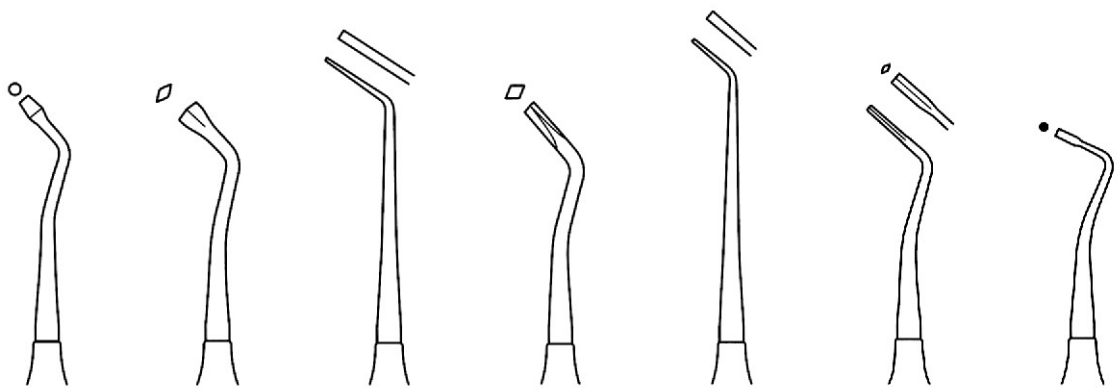

DS-60-2041 Fig. M5
 DS-60-2042 Fig. M6
 DS-60-2043 Fig. H1 Hollenback
 DS-60-2044 Fig. H2 Hollenback
 DS-60-2045 Fig. H3 Hollenback
 DS-60-2046 Fig. H4 Hollenback
 DS-60-2047 Fig. MQ 1S

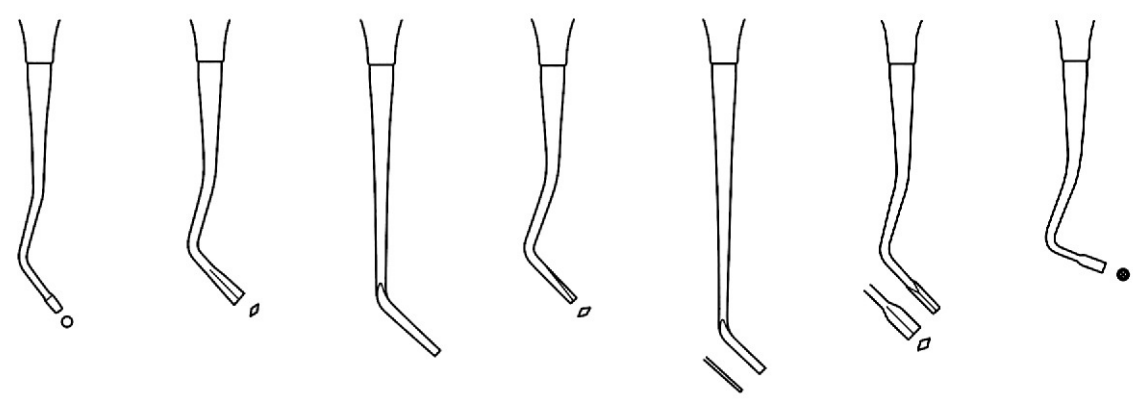

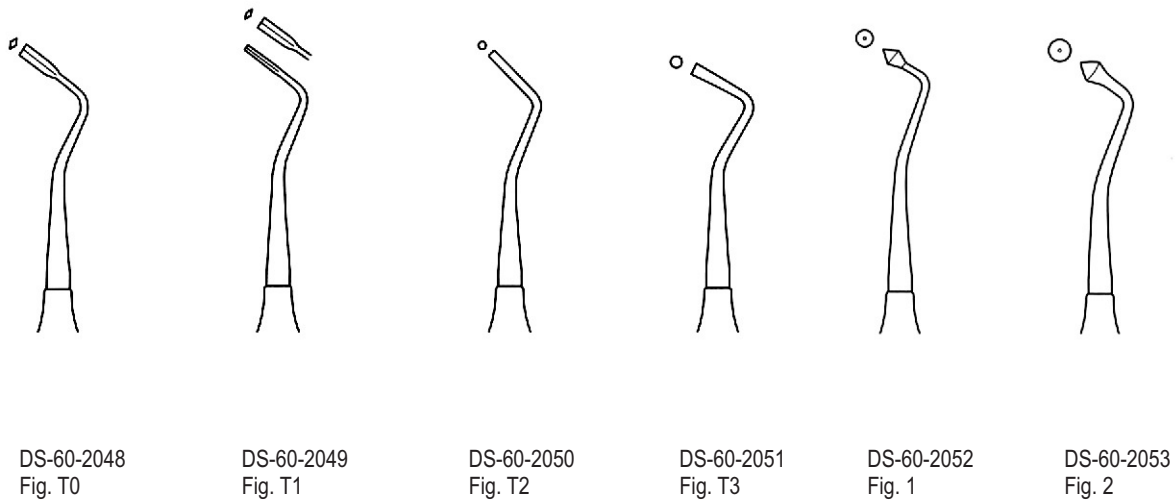

DS-60-2048
 Fig. T0

DS-60-2049
 Fig. T1

DS-60-2050
 Fig. T2

DS-60-2051
 Fig. T3

DS-60-2052
 Fig. 1

DS-60-2053
 Fig. 2

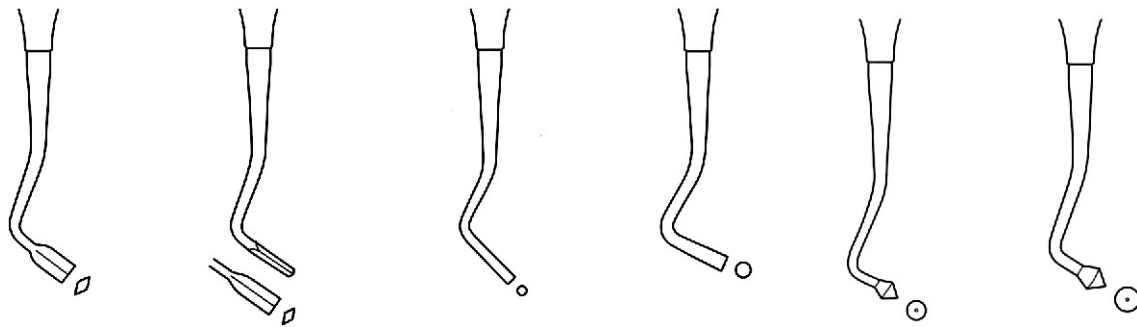



DS-60-2054
Fig. 3

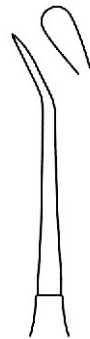

DS-60-2055
Fig. WO 1
Woodson



DS-60-2056
Fig. WO 2
Woodson



DS-60-2057
Fig. WO 3
Woodson



DS-60-2058
Fig. L2
Ladmore

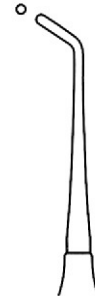

DS-60-2059
Fig. L3
Ladmore

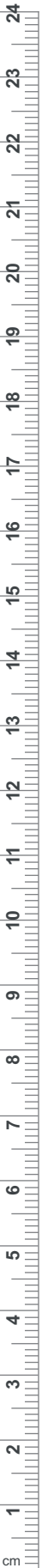

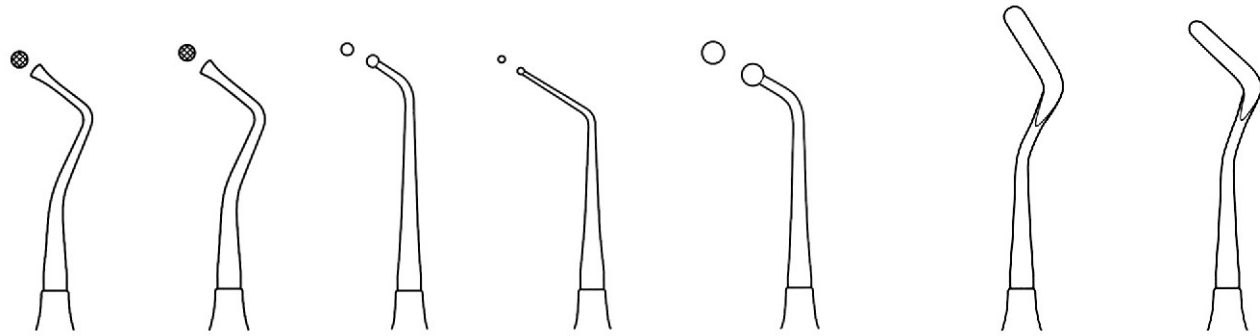

DS-60-2060
 Fig. 1
 Ward

DS-60-2061
 Fig. 2
 Ward

DS-60-2062
 Fig. 7A

DS-60-2063
 Fig. 19

DS-60-2064
 Fig. 7B

DS-60-2065
 Fig. 6

DS-60-2066
 Fig. 11

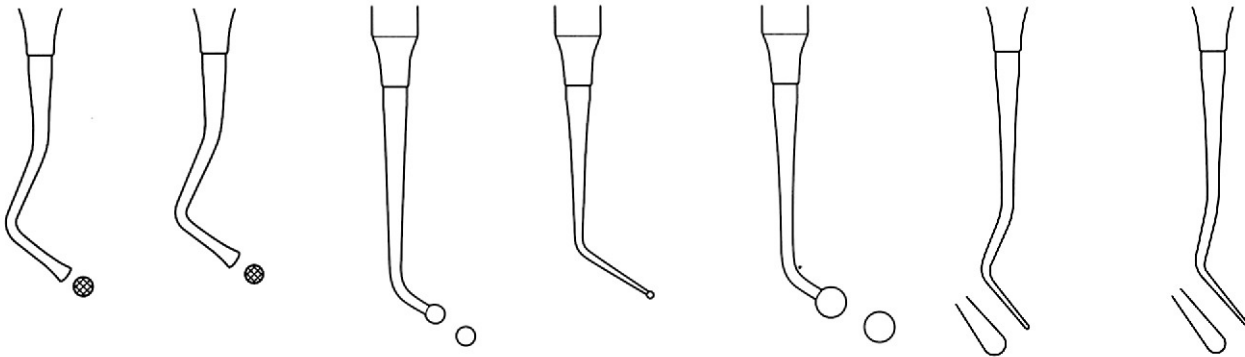

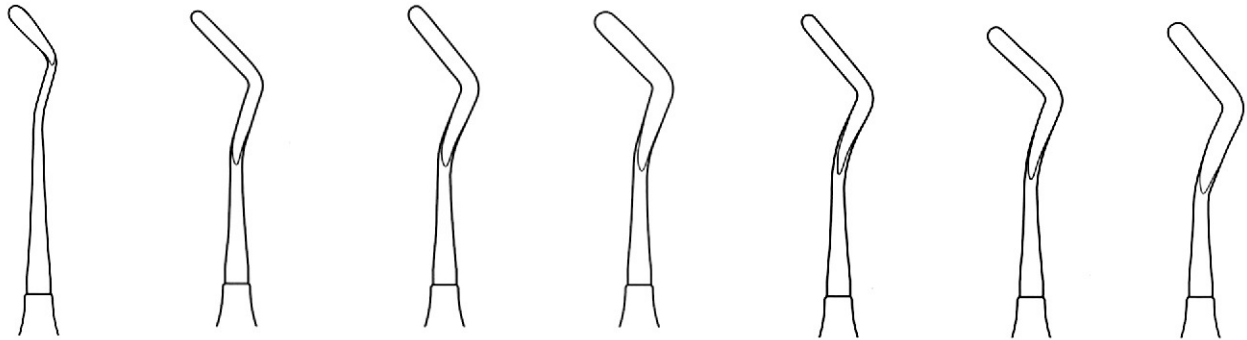

DS-60-2067
Fig. 179

DS-60-2068
Fig. 1
2 mm

DS-60-2069
Fig. 2
2.5 mm

DS-60-2070
Fig. 3
3 mm

DS-60-2071
Fig. 11

DS-60-2072
Fig. 12

DS-60-2073
Fig. 13

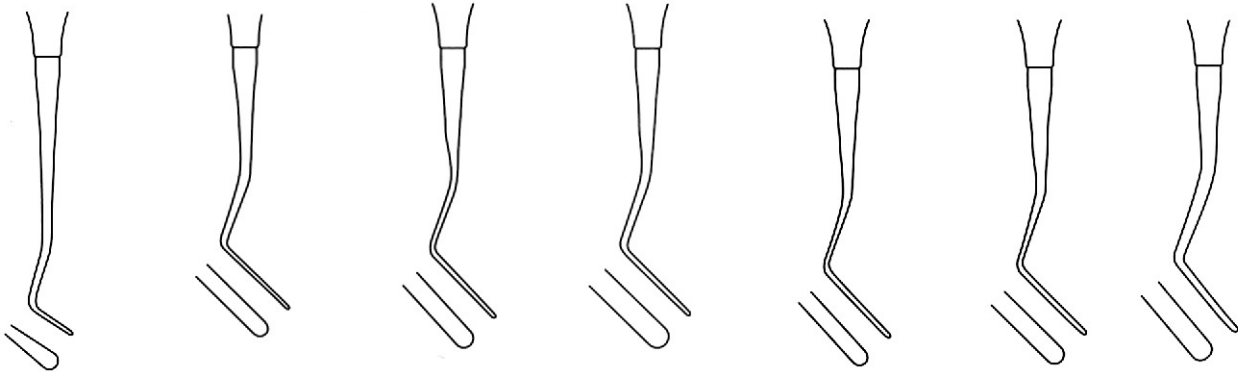

61

- EN** Gingivectomy Knives
- DE** Gingivektomie Messer
- ES** Cuchillos de gingivectomía

Page 106 to 107

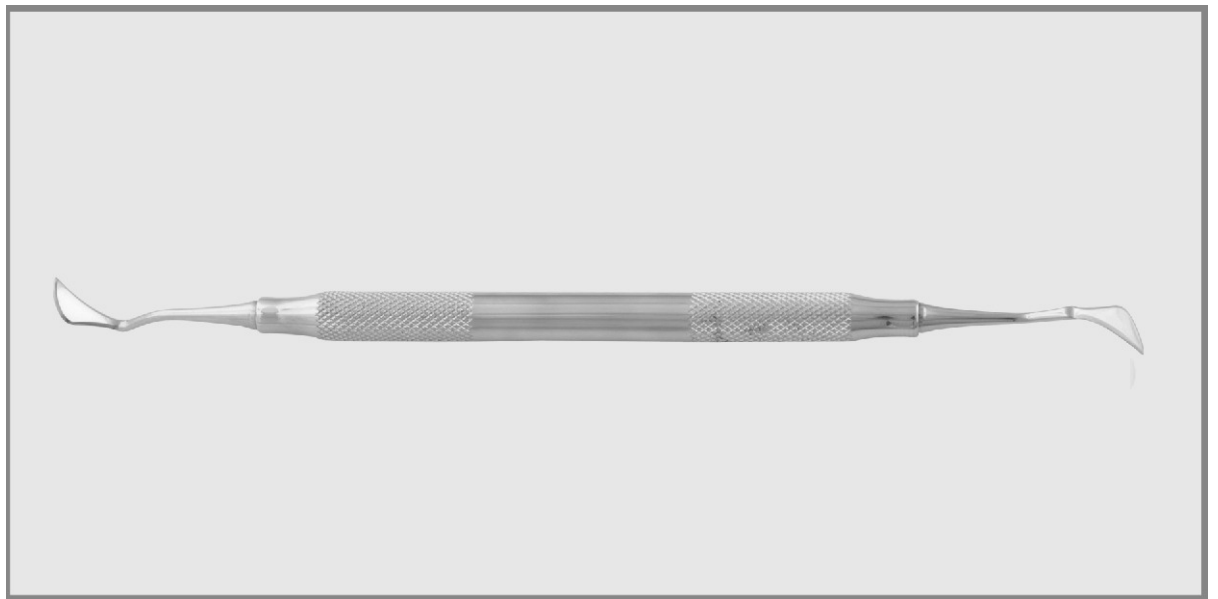

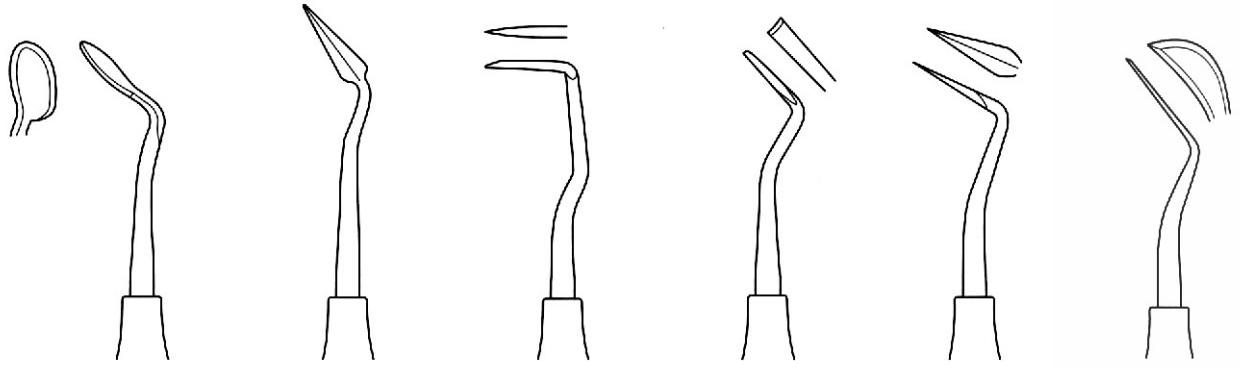

DS-61-2101
 Goldman-Fox
 Fig. 7

DS-61-2102
 Goldman-Fox
 Fig. 8

DS-61-2103
 Goldman-Fox
 Fig. 9

DS-61-2104
 Goldman-Fox
 Fig. 10

DS-61-2105
 Goldman-Fox
 Fig. 11

DS-61-2106
 Kirkland
 Fig. 15K/16K

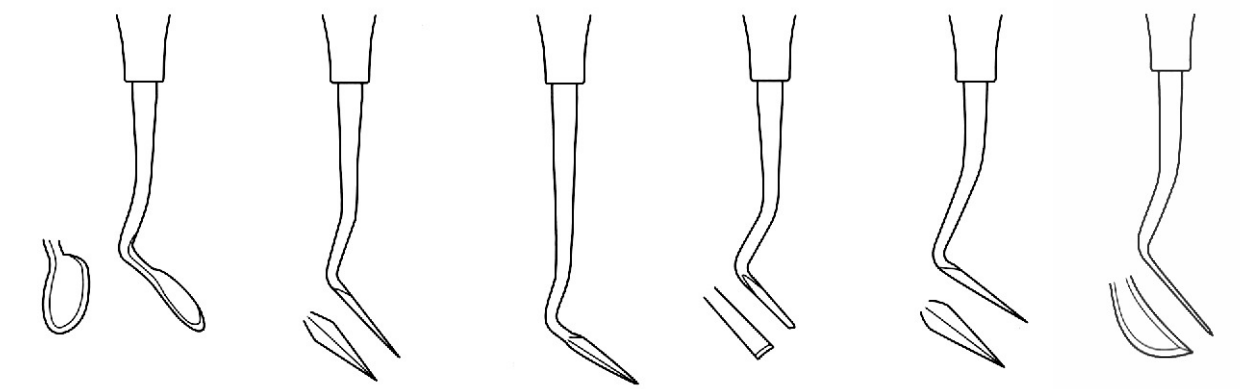

Periodontal Knives — EN
 Parodontale Messer — DE
 Cuchillos periodontales — ES

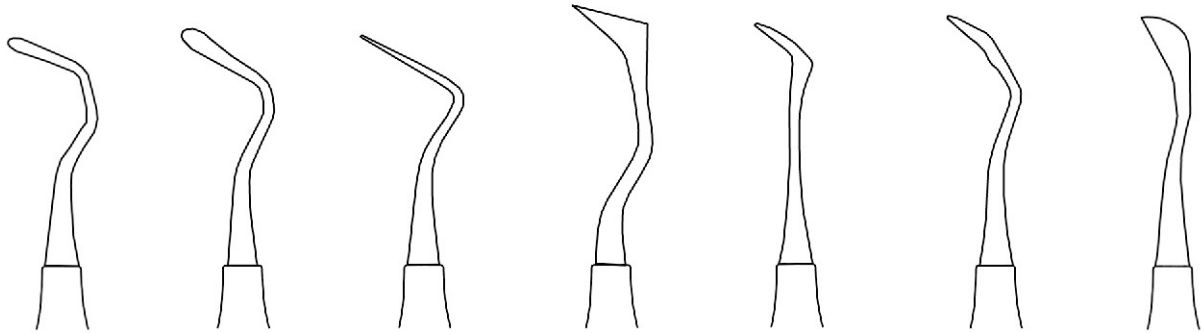

DS-61-2107 Fig. 1 Reddy Thin	DS-61-2108 Fig. 2 Reddy Thin	DS-61-2109 Fig. 1/2 Sanders	DS-61-2110 Fig. 19/20 USC Towner	DS-61-2111 Fig. CK-3 Crane Kaplan	DS-61-2112 Fig. CK-6 Crane Kaplan	DS-61-2113 Fig. 1/2 Solt
------------------------------------	------------------------------------	-----------------------------------	--	---	---	--------------------------------

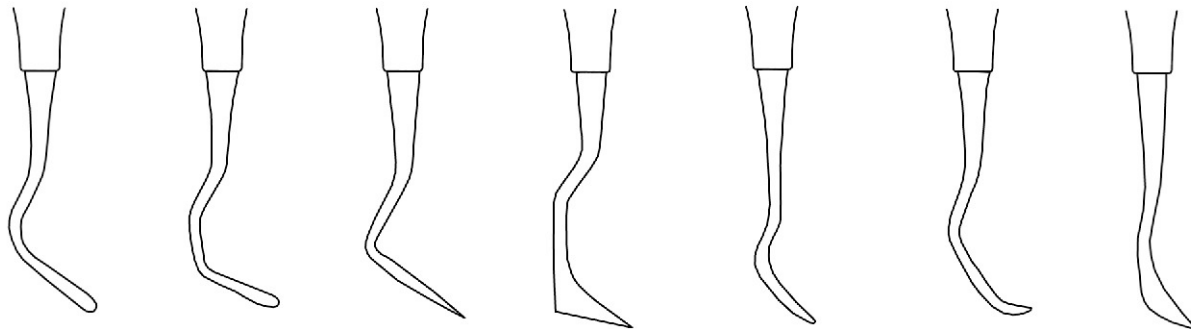

62

- EN** Cement Spatulas
- DE** Zementspatel
- ES** Espátulas de cemento

Page 108 to 112

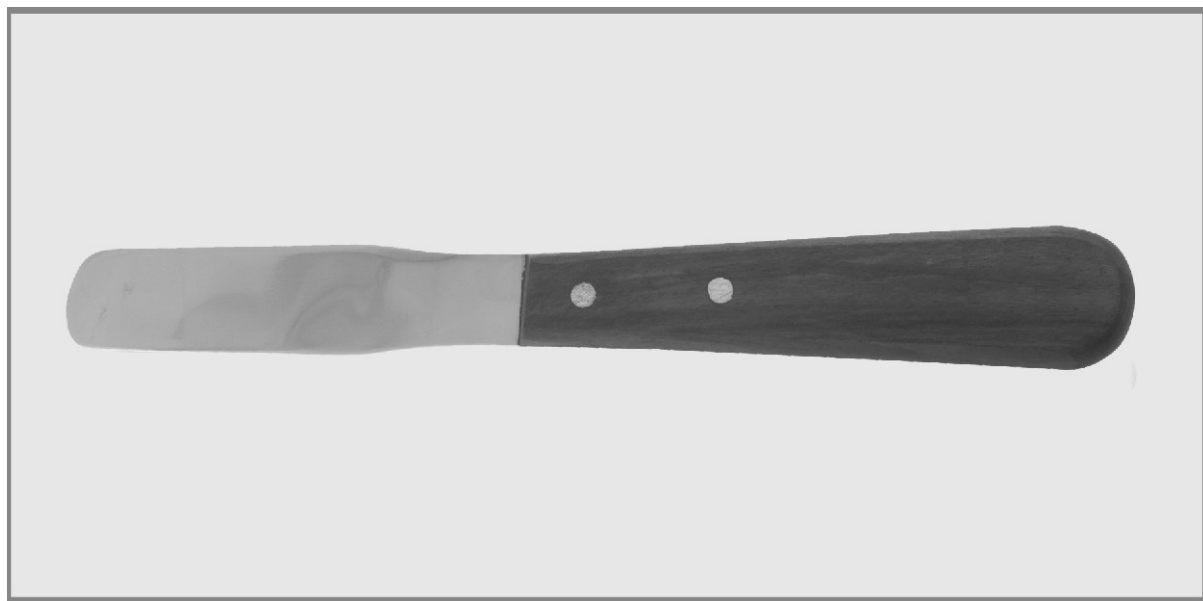



DS-62-2151
Fig. 26
Distal

DS-62-2152
Fig. 27
Mesial

DS-62-2153
Fig. 29
Mesial

DS-62-2154
Fig. 29
Mesial

DS-62-2155
Fig. 77/78
Distal

DS-62-2156
Mesial
54-1142-00

DS-62-2157
Fig. 28
Distal

Wooden Handle

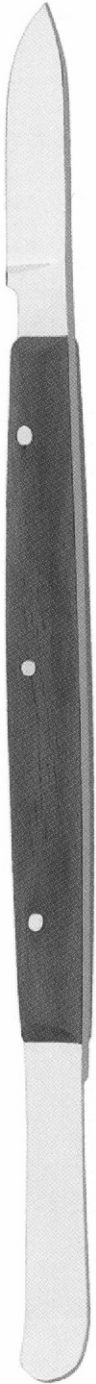

DS-62-2158
 Fig. 28
 Distal



DS-62-2159
 Fig. 28
 Distal



DS-62-2160
 Fig. 28
 Distal



DS-62-2161
 Fig. 28
 Distal

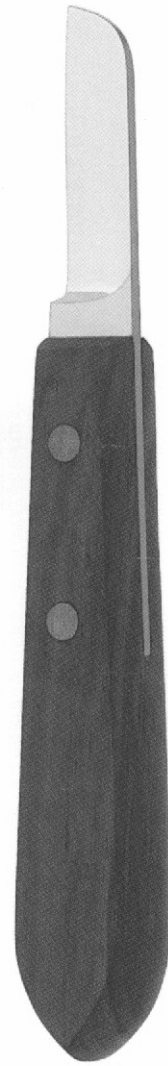

DS-62-2162
 Fig. 28
 Distal





DS-62-2163
Fig. 1



Fig. 2



Fig. 3



Fig. 4



Fig. 5



Fig. 1



Fig. 2
DS-62-2164

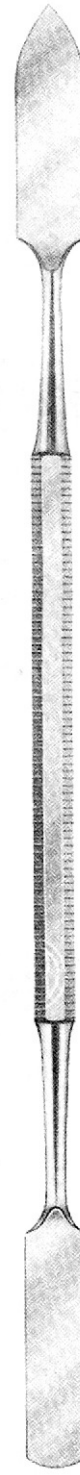
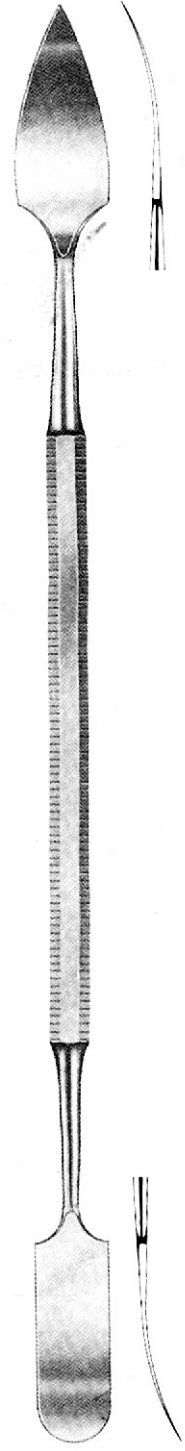

Fig. 3



DS-62-2165
Fig. 31
Gritman



DS-62-2166
 Fig. 1

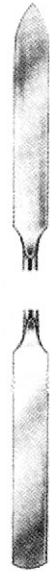

Fig. 2



Fig. 3



DS-62-2167
 Fig. 1

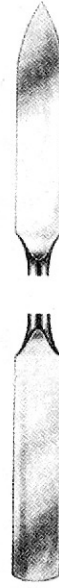

Fig. 2



Fig. 5



Fig. 3



Fig. 6



Fig. 4



Fig. 7





DS-62-2168
Fig. 1



Fig. 2



Fig. 4



Fig. 5



DS-62-2169
Fig. 313



Fig. 322



Fig. 324

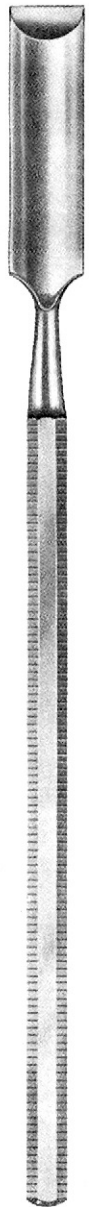

DS-62-2170



Fig. 6



Fig. 7



Fig. 8



Fig. 5



Fig. 8



Fig. 24 A



Fig. 25 E



Fig. 11

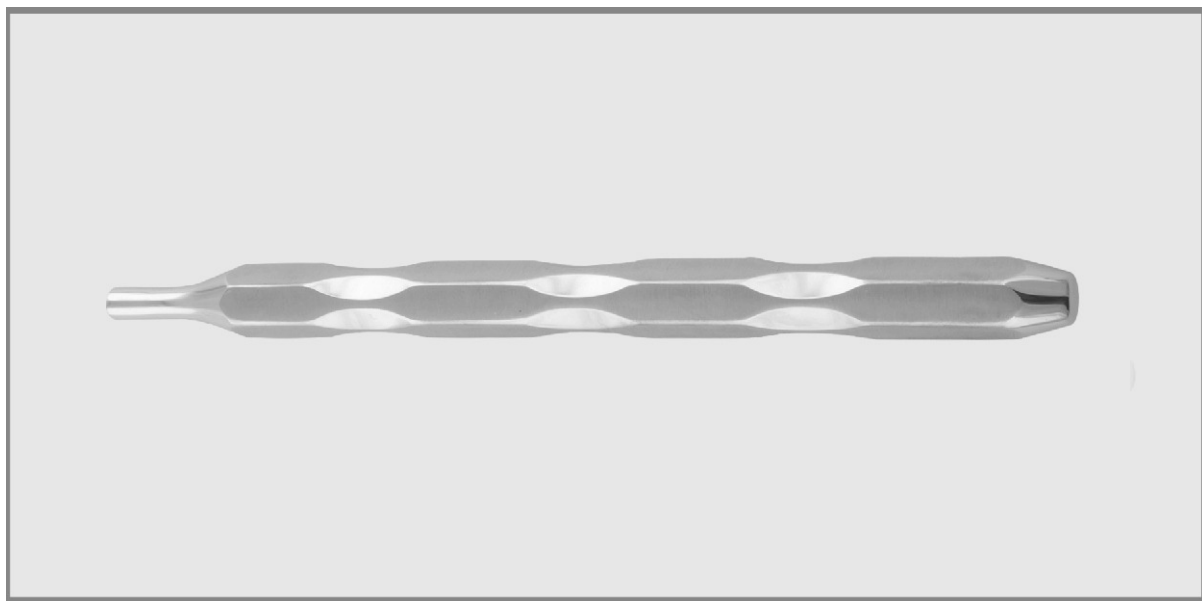

Fig. 12

63

- EN** Mouth Mirrors
- DE** Mundspiegel
- ES** Espejos bucales

Page 113 to 115





Simple Stem



Plain
Magnifying
Front Surface

1 = 16 mm
 3 = 20 mm
 4 = 22 mm
 5 = 24 mm

DS-63-2301-16
 DS-63-2301-20
 DS-63-2301-22
 DS-63-2301-24



Plain
Magnifying
Front Surface

4 = 22 mm
 5 = 24 mm

DS-63-2302-22
 DS-63-2302-24



Plain
Magnifying
Front Surface

3 = 20 mm
 4 = 22 mm
 5 = 24 mm

DS-63-2303-20
 DS-63-2303-22
 DS-63-2303-24

Cone Socket

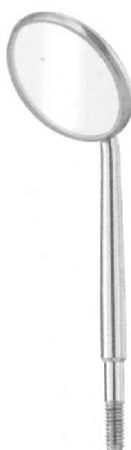

Plain
Magnifying
Front Surface

3 = 20 mm
 4 = 22 mm
 5 = 24 mm

DS-63-2304-20
 DS-63-2304-22
 DS-63-2304-24



Plain
Magnifying
Front Surface

3 = 20 mm
 4 = 22 mm
 5 = 24 mm

DS-63-2305-20
 DS-63-2305-22
 DS-63-2305-24

Mouth mirror handles — EN
 Mundspiegelgriff — DE
 Manches pour miroirs á bouche — ES



DS-63-2306-01
 4,5 cm/13/4



DS-63-2306-02
 Handle only

HILGER
 DS-63-2306-00
 18 cm/7"



DS-63-2307-14
 Hollow

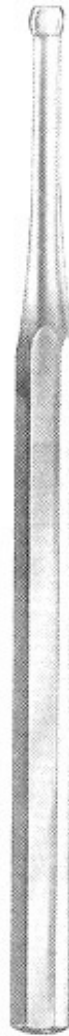

DS-63-2308-14
 Hollow



DS-63-2309-14
 Hollow

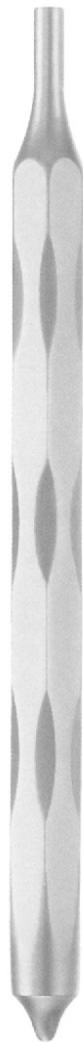

DS-63-2310-14
 Hollow

Mirror handles are available with Cone Socket and Simple Stem Fittings
 Matric / US Threads, Please specify while ordering

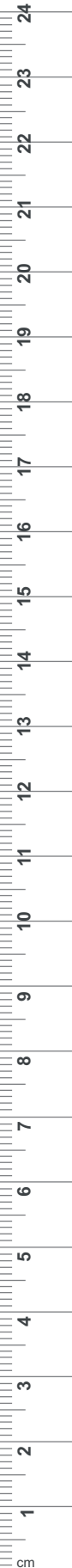



DS-63-2311-12
Hollow



DS-63-2312-12
Solid



DS-63-2313-12
Solid



DS-63-2314-12
Solid



DS-63-2315-00
Solid



DS-63-2316-00
Hollow

Mirror handles are available with Cone Socket and Simple Stem Fittings
 Matric / US Threads, Please specify while ordering

64

- EN** Amalgam Instruments
- DE** Amalgam Instrumente
- ES** Instrumentos de amalgama

Page 116 to 117

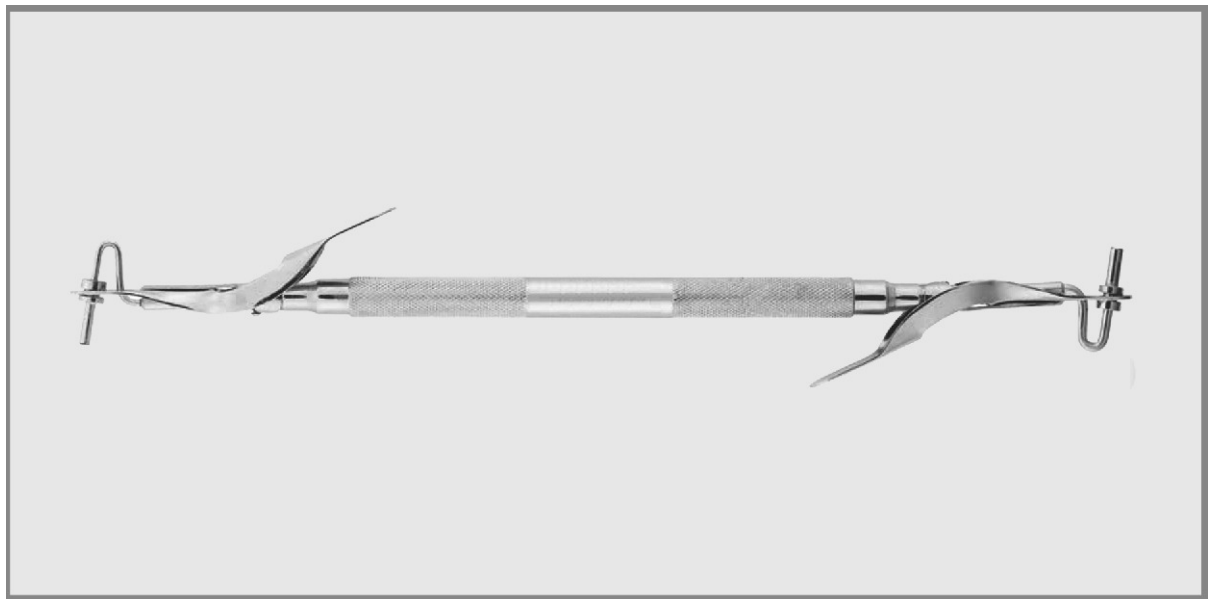

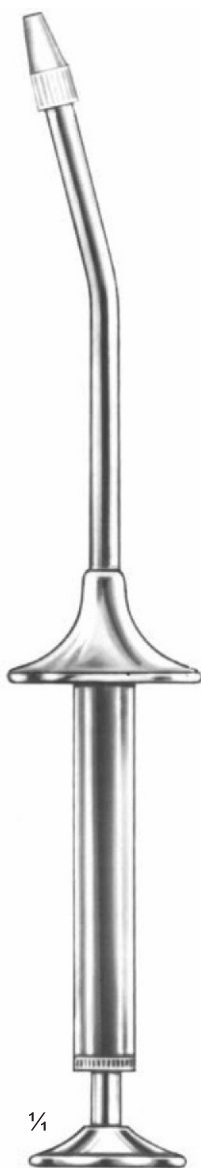

1/4

with metal tip
with plastic tip

DS-64-2351
DS-64-2352

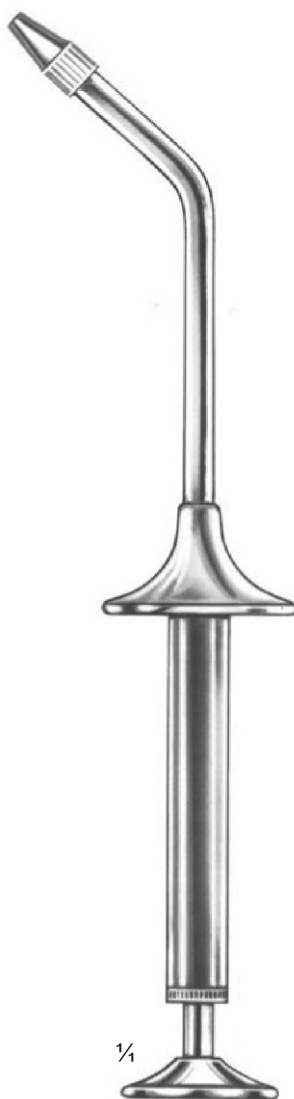

1/4

DS-64-2353
DS-64-2354

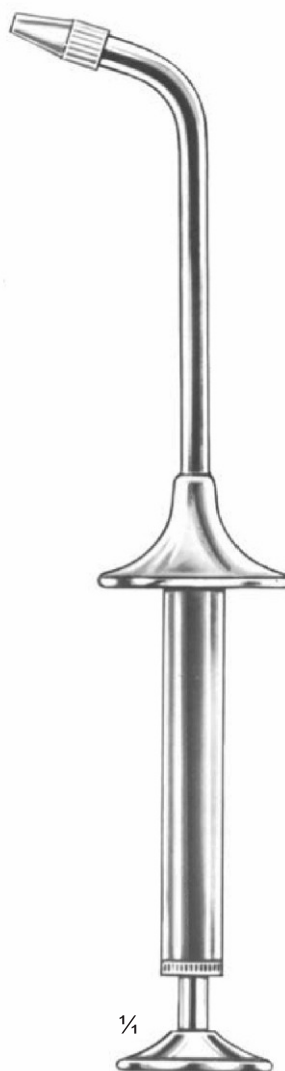

1/4

DS-64-2355
DS-64-2356



1/4

DS-64-2357
DS-64-2358

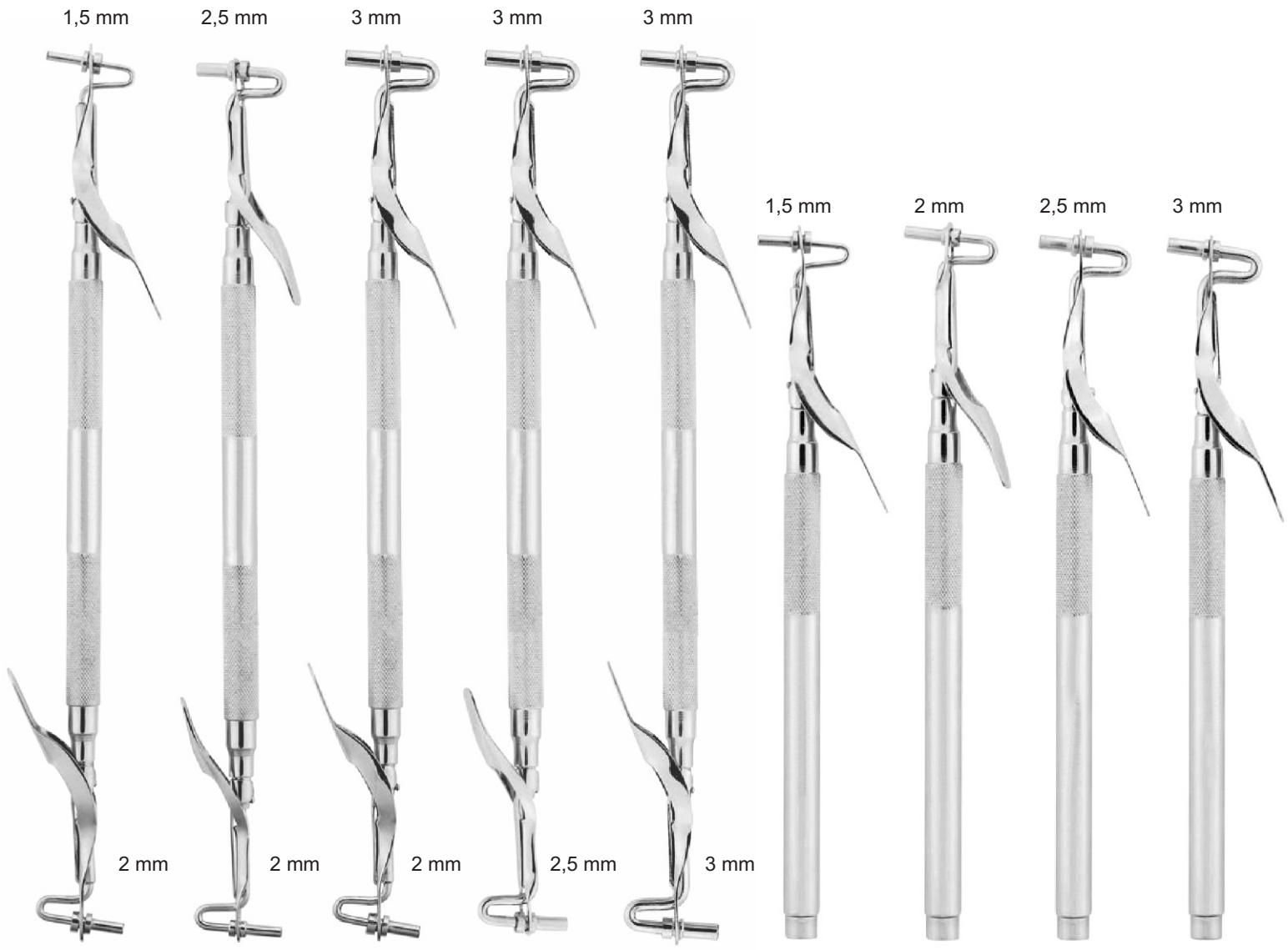

1,5 mm

2,5 mm

3 mm

3 mm

3 mm

1,5 mm

2 mm

2,5 mm

3 mm

2 mm

2 mm

2 mm

2,5 mm

3 mm

DS-64-2361
 Medium/small
 20 cm

DS-64-2362
 Medium/Large
 20 cm

DS-64-2363
 Medium/Jumbo
 20 cm

DS-64-2364
 Large/Jumbo
 20 cm

DS-64-2365
 Jumbo/Jumbo
 20 cm

DS-64-2366
 small
 15,5 cm

DS-64-2367
 Medium
 15,5 cm

DS-64-2368
 Large
 15,5 cm

DS-64-2369
 Jumbo
 15,5 cm



65

EN

Matrix Retainers

DE

Matrix-Halterungen

ES

Retenedores de matrices

Page 118 to 125





Tofflemire-Universal
DS-65-2601



Tofflemire-Senior
DS-65-2602



Tofflemire-Junior
DS-65-2603



Fig.1
Nystrom
left
DS-65-2604



Fig.2
Nystrom
right
DS-65-2605



Ivory 8
DS-65-2606 5 mm
DS-65-2607 6 mm
DS-65-2608 7 mm



Ivory 8N
DS-65-2609



adjustable

Didner 8P
DS-65-2610

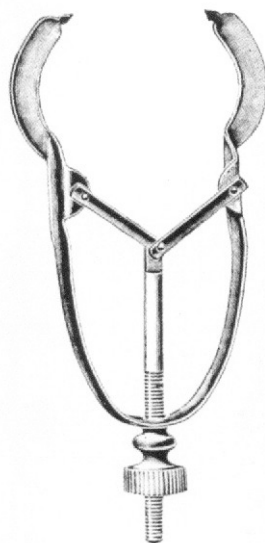

Ivory
DS-65-2611
Fig. 1

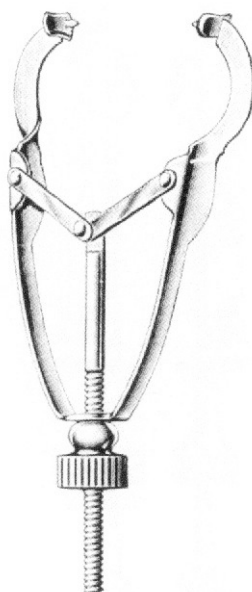

Ivory
DS-65-2612
Fig. 12

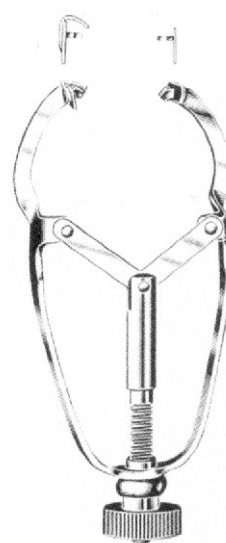

Ivory
DS-65-2613
Fig. 12A





Ainsworth
DS-65-2614
16 cm / 6 1/2"



Ainsworth
DS-65-2615
16 cm / 6 1/2"

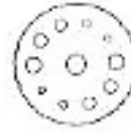

Ivory
DS-65-2616
15 cm / 6"



Ivory
DS-65-2617
15 cm / 6"



Ivory
DS-65-2618
17 cm / 6 3/4"



Brewer
DS-65-2619
17 cm / 6 3/4"



Stockes
 DS-65-2620
 17 cm / 6 3/4"

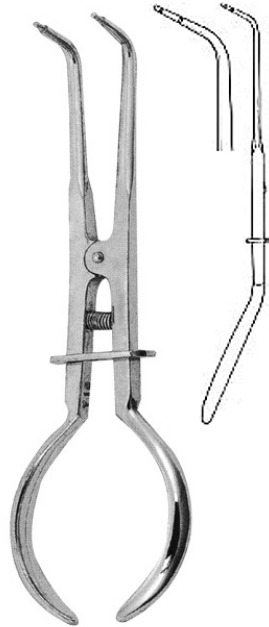

Stockes
 DS-65-2621
 17 cm / 6 3/4"



Palmer
 DS-65-2622
 17 cm / 6 3/4"



White
 DS-65-2623
 17 cm / 6 3/4"



Band Pusher-Mershon
 DS-65-2624
 14 cm / 5 1/2"

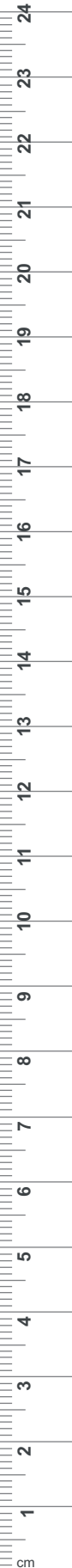



DS-65-2626
Fig. 00
Anterior Teeth



DS-65-2627
Fig. 0
Premolars



DS-65-2628
Fig. 1
Premolars



DS-65-2629
Fig. 1A
Premolars



DS-65-2630
Fig. 2
Premolars



DS-65-2631
Fig. 2A
Premolars



DS-65-2632
Fig. 2AS
Premolars



DS-65-2633
Fig. 3
Lower Molars



DS-65-2634
Fig. 4
Upper Molars



DS-65-2635
Fig. 5
Upper Molars



DS-65-2636
Fig. 6
Anterior Teeth



DS-65-2637
Fig. 7
Lower Molars



DS-65-2638
Fig. 7A
Lower Molars



DS-65-2639
Fig. 8
Upper Molars



DS-65-2640
Fig. 8A
Molars General



DS-65-2641
Fig. 9
Anterior Teeth



DS-65-2642
Fig. 9S
Anterior Teeth



DS-65-2643
Fig. 10
Molars General



DS-65-2644
Fig. 11
Molars General



DS-65-2645
Fig. 24
Molars General



DS-65-2646
Fig. 25
Molars General



DS-65-2647
Fig. 26
Lower Molars



DS-65-2648
Fig. 26N
Molars General



DS-65-2649
Fig. 27
Molars General



DS-65-2650
 Fig. 27N
 Premolars



DS-65-2651
 Fig. 28
 Lower Molars



DS-65-2652
 Fig. 29
 Lower Molars



DS-65-2653
 Fig. 30
 Upper Molars



DS-65-2654
 Fig. 31
 Upper Molars



DS-65-2655
 Fig. 56
 Molars General



DS-65-2656
 Fig. 56S
 Molars General



DS-65-2657
 Fig. 201
 Upper Molars



DS-65-2658
 Fig. 205
 Upper Molars



DS-65-2659
 Fig. 212
 Anterior Teeth



DS-65-2660
 Fig. 212SA
 Anterior Teeth



DS-65-2661
 Premolars
 12-06DS-65-W2



DS-65-2662
 Fig. W3
 Lower Molars



DS-65-2663
 Fig. W4
 Upper Molars



DS-65-2664
 Fig. W7
 Lower Molars

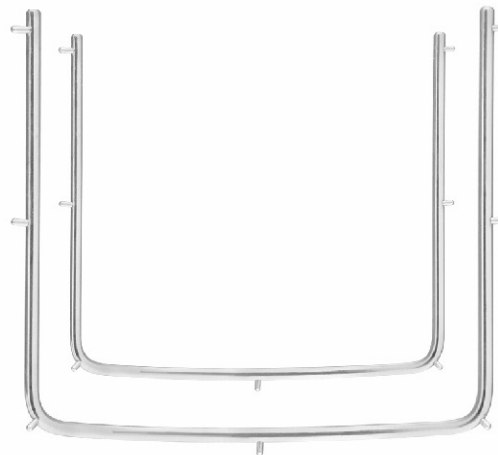

DS-65-2665 Frame - Child
 13 cm/5"
 DS-65-2666 Frame - Adult
 15 cm/6"

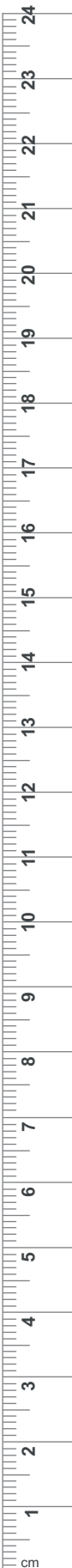



DS-65-2667
Beerendonk

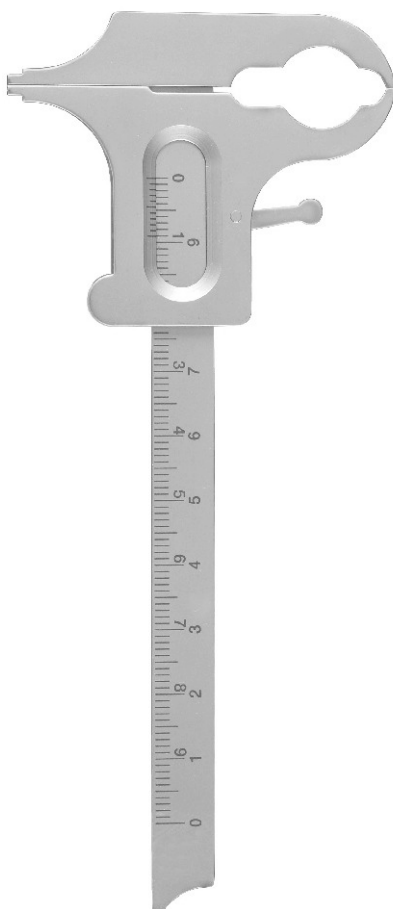

DS-65-2668
Boley



Iwanson
 One side graugation
 DS-65-2669 Metal
 DS-65-2670 Wax

Double side graugation
 DS-65-2671 Metal
 DS-65-2672 Wax

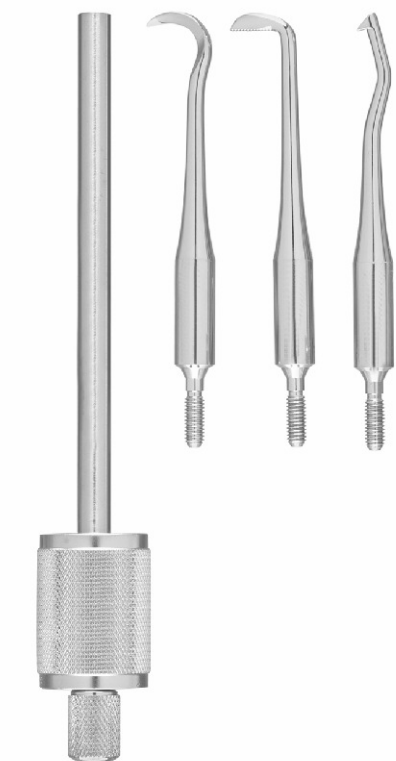

DS-65-2673
 Morrel
 Crown Remover



DS-65-2674
 Crown Remover
 Manual



DS-65-2675
 Crown Remover
 Manual



DS-65-2676
 Crown Remover
 Automatic



DS-65-2677
 Crown Remover
 Automatic



66

- EN** Hemostatic Forceps
- DE** Arterienklemmen
- ES** Pincas hemostaticas

Page 126 to 132

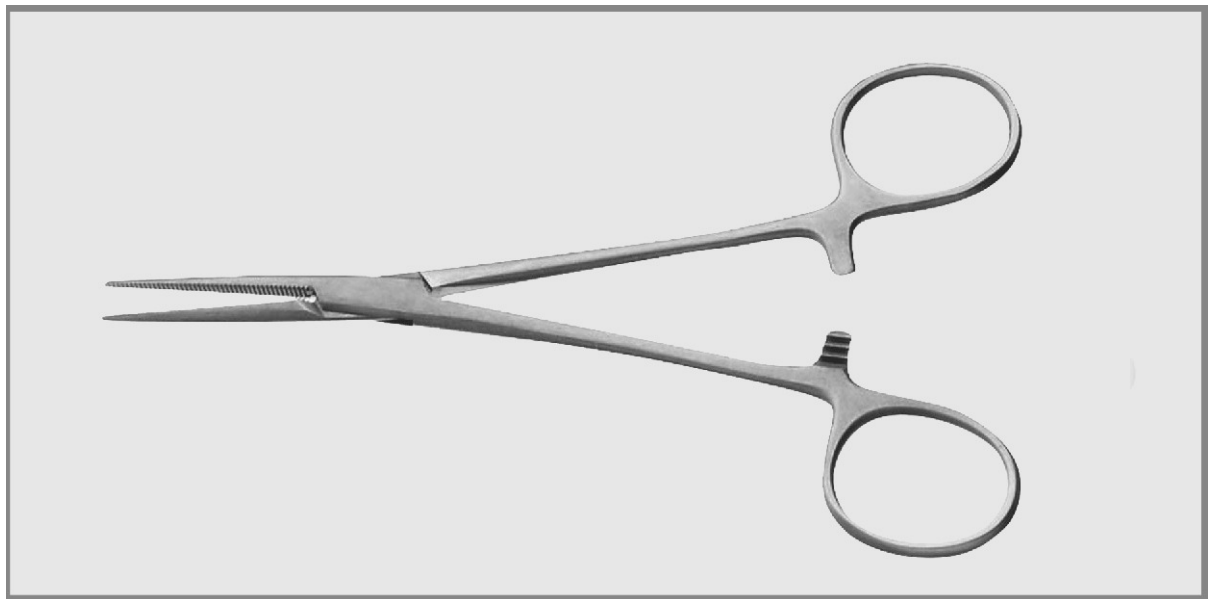



Halsted-Mosquito



DS-66-2701
12.5 cm/5"



DS-66-2702
14.5 cm/5 3/4"



DS-66-2703
14 cm/5 1/2"



DS-66-2704
12.5 cm/5"
1:2



DS-66-2705
14.5 cm/5 3/4"
1:2



DS-66-2706
12 cm/4 3/4"
1:2



DS-66-2707
14 cm/4 1/2"
1:2



Micro-Mosquito



DS-66-2708
10 cm/4"



DS-66-2709
12 cm/4 3/4"

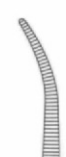

DS-66-2710
9.5 cm/3 1/2"



DS-66-2711
11.5 cm/4 1/2"



DS-66-2712
10 cm/4"
1:2



DS-66-2713
12 cm/4 3/4"
1:2



DS-66-2714
10 cm/4"
1:2



DS-66-2715
12 cm/4 3/4"
1:2



Halsted-Mosquito



DS-66-2716
18 cm/7"

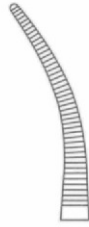

DS-66-2717
18 cm/7"



DS-66-2718
18 cm/7"
1:2



DS-66-2719
18 cm/7"
1:2



Leriche



DS-66-2720
15 cm/6"

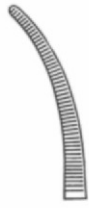

DS-66-2721
15 cm/6"



DS-66-2722
15 cm/6"
1:2

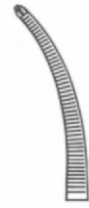

DS-66-2723
15 cm/6"
1:2

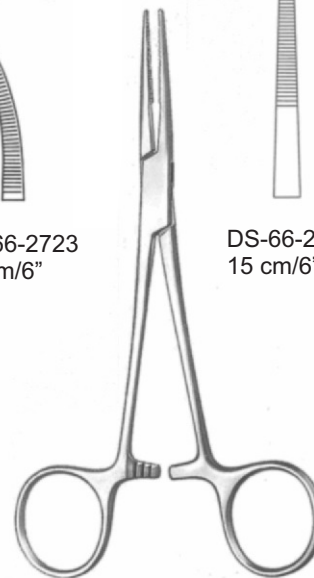

Kelly



DS-66-2724
15 cm/6"



DS-66-2725
15 cm/6"

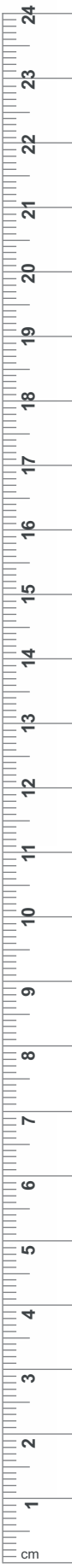

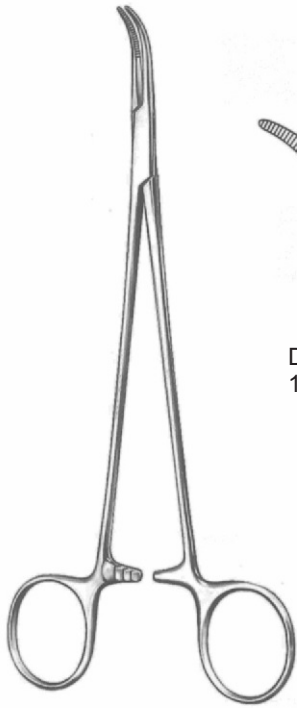

Mixer-Baby

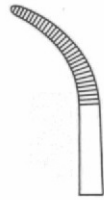

DS-66-2726
18.5 cm/7 1/4"

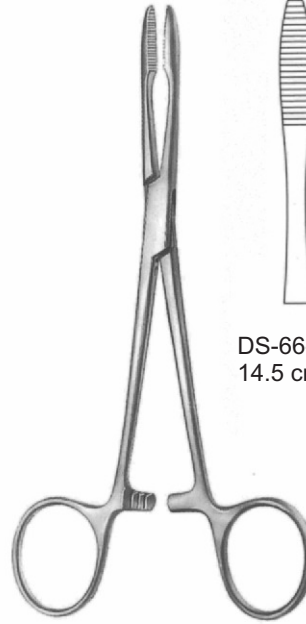

Pean



DS-66-2727
14.5 cm/5 3/4"



DS-66-2728
16 cm/6 1/4"



Pean



DS-66-2729
13 cm/5"



DS-66-2730
14 cm/5 1/2"

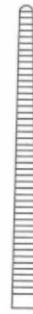

DS-66-2731
17 cm/6 3/4"



DS-66-2732
13 cm/5"



DS-66-2733
14 cm/5 1/2"



DS-66-2734
17 cm/6 3/4"

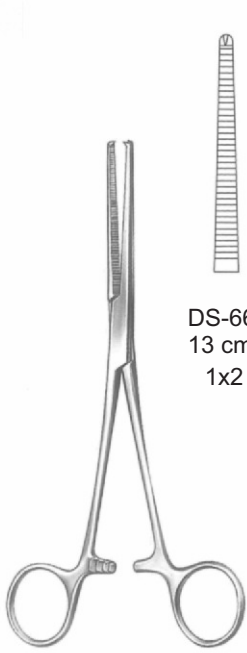

Kocher

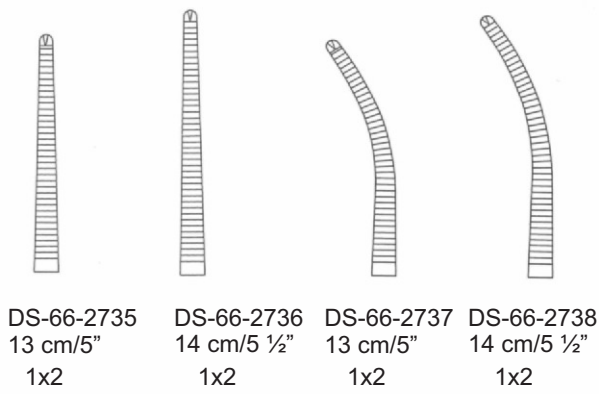

DS-66-2735
13 cm/5"
1x2

DS-66-2736
14 cm/5 1/2"
1x2

DS-66-2737
13 cm/5"
1x2

DS-66-2738
14 cm/5 1/2"
1x2

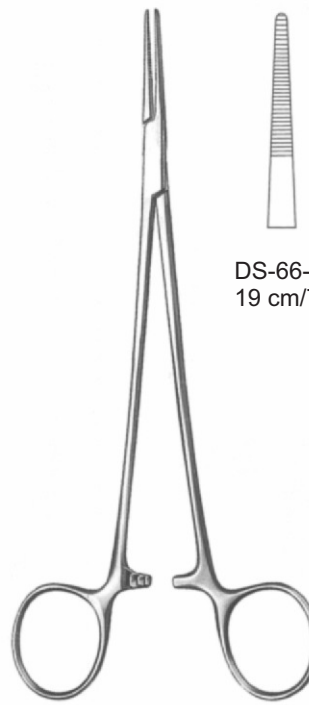

Adson

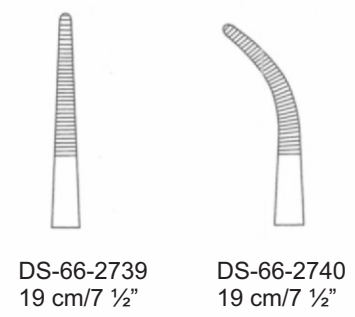

DS-66-2739
19 cm/7 1/2"

DS-66-2740
19 cm/7 1/2"



Gross-Maier

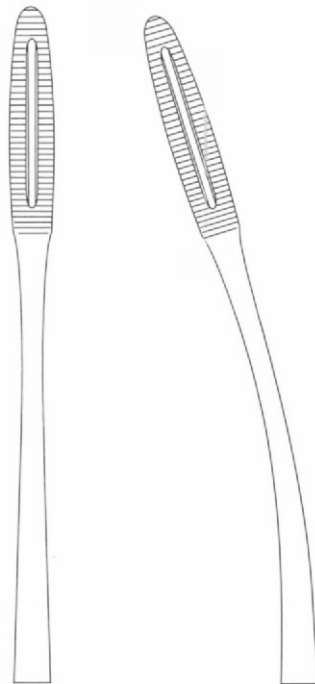

DS-66-2741
20 cm/8"

DS-66-2742
20 cm/8"



DeBakey-Mosquito

ATRAUMA

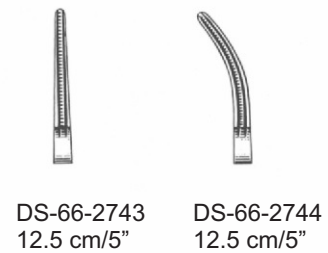

DS-66-2743
12.5 cm/5"

DS-66-2744
12.5 cm/5"

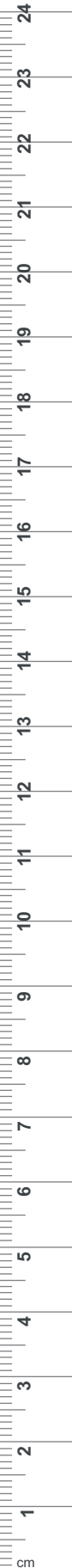



Babcock

- DS-66-2745 16 cm/6 1/4"
- DS-66-2746 18 cm/7 1/8
- DS-66-2747 20 cm/7 7/8
- DS-66-2748 24 cm/9 1/2

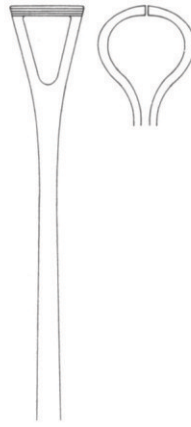

Babcock

DS-66-2749 TC
 16 cm/6 1/2

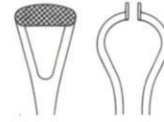

ATRAUMA

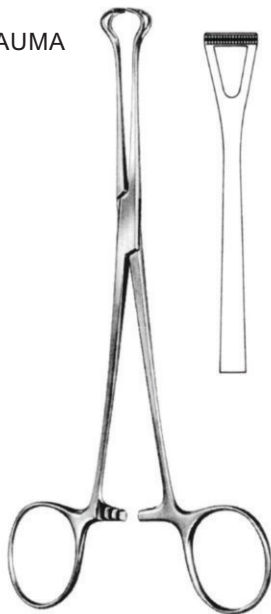

BABCOCK
 DS-66-2750
 16 cm/9 1/4

ATRAUMA

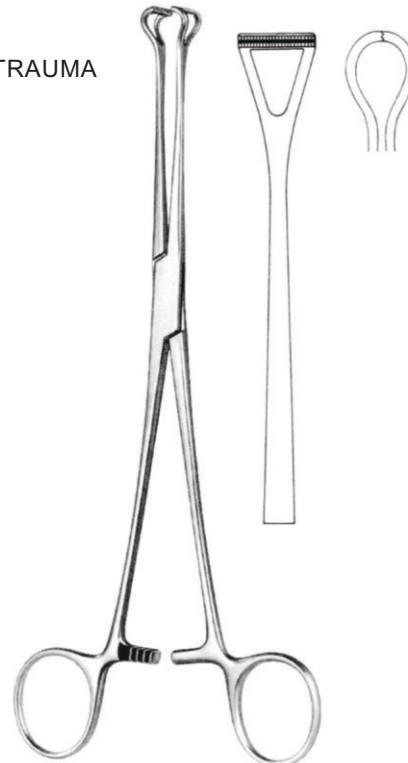

BABCOCK
 DS-66-2751
 20.5 cm/8 1/8

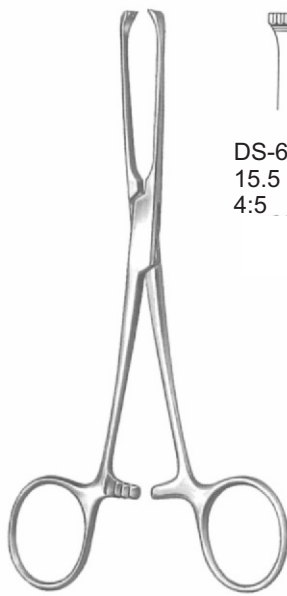

Allis

DS-66-2752
 15.5 cm/6"
 4:5



DS-66-2753
 15.5 cm/6"
 5:6



DS-66-2754
 19 cm/7 1/2"
 5:6

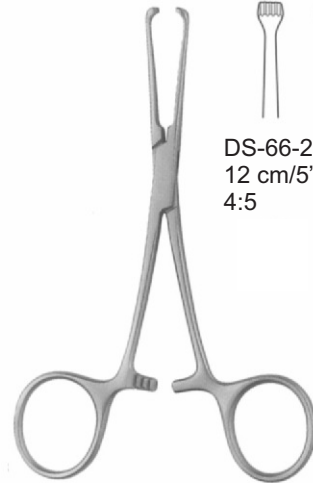

Allis-Baby

DS-66-2755
 12 cm/5"
 4:5

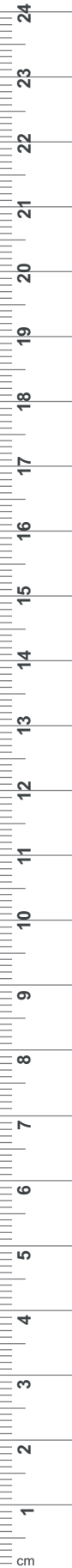

ATRAUMA



Allis



DS-66-2756
16 cm/6 1/2"



DS-66-2757
20 cm/8"

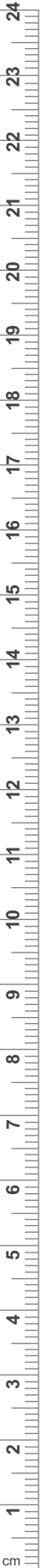

67

- EN** Towel Clamps
- DE** Handtuchklammern
- ES** Abrazaderas de toalla

Page 133 to 134

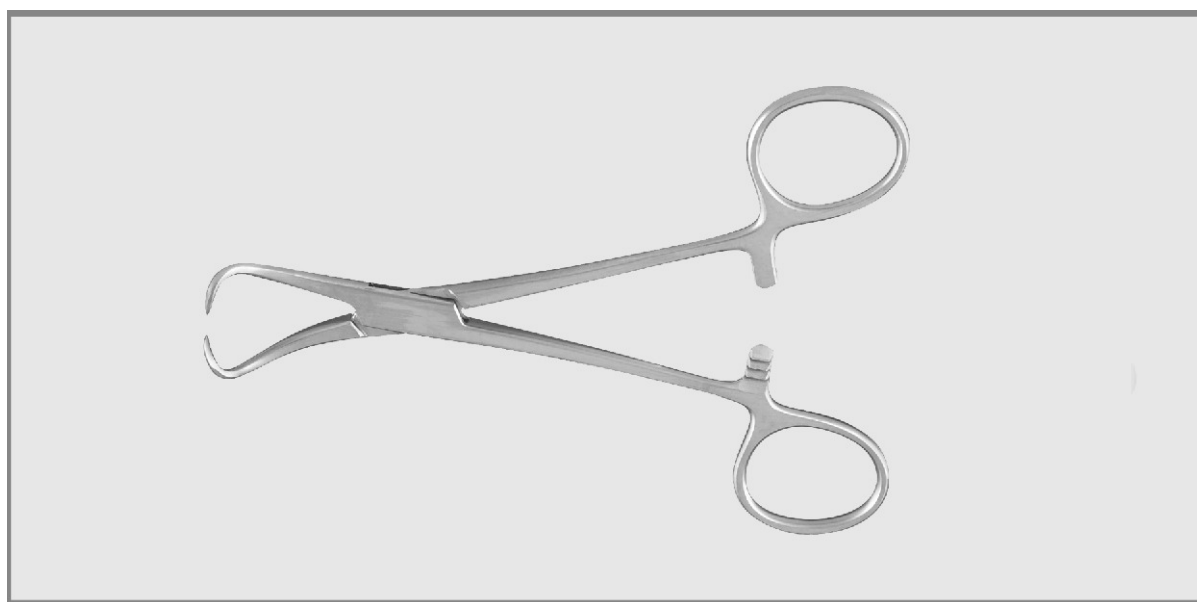

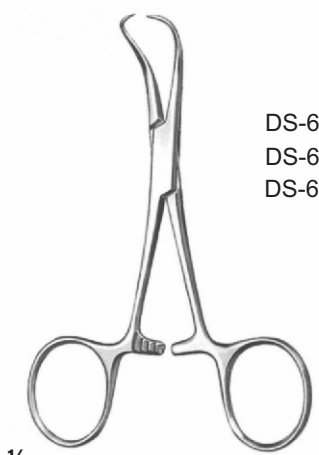

1/2

Backhaus

DS-67-2801 9 cm/3 1/2"
 DS-67-2802 11.5 cm/4 1/2"
 DS-67-2803 13 cm/5"



1/2

for paper clothes

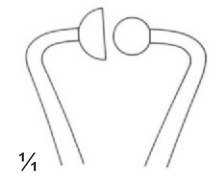

1/4

DS-67-2804
 11.5 cm/4 1/2"

DS-67-2805
 14 cm/5 1/2"



1/2

Peers-Bertram
 DS-67-2806
 14.5 cm/5 3/4"

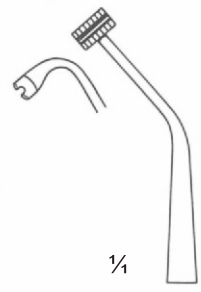

1/4

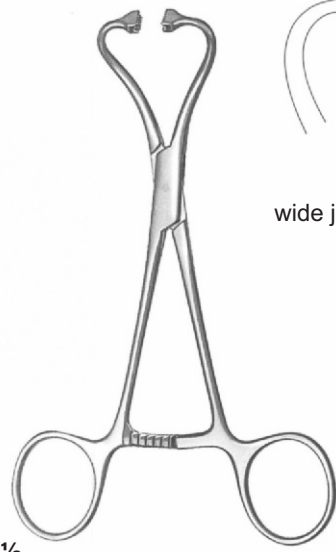

1/2

Peers-Bertram modif.
 DS-67-2807
 15.5 cm/6"

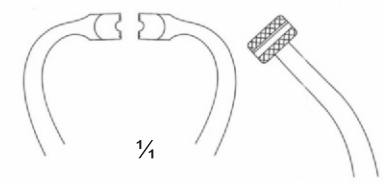

1/4

wide jaw for tube fixation



DS-67-2808
10.5 cm/4"

DS-67-2809
13.5 cm/5 1/4"



Schadel
DS-67-2810
8.5 cm/3 1/2"
sharp



Jones
sharp

DS-67-2811
8.5 cm/3 1/4"

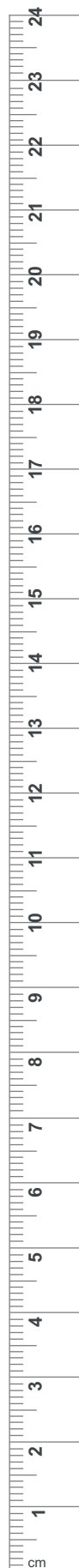

68

EN Needle Holders

DE Nadelhalter

ES Porte-aiguilles

Page 135 to 143



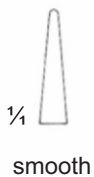
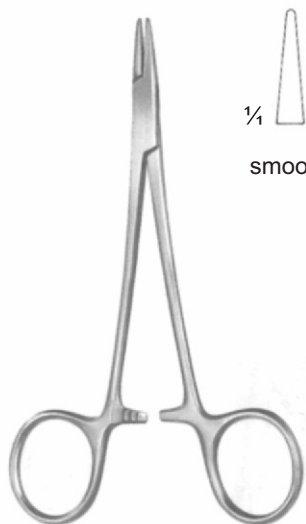

Webster
 DS-68-2901
 13 cm/5 1/8"

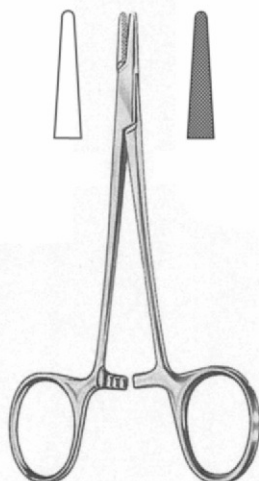

Halsey

DS-68-2902 13 cm/5 1/8" Plain
 DS-68-2903 13 cm/5 1/8" Serrated

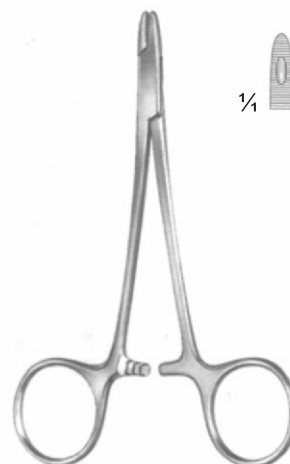

Derf

DS-68-2904
 12 cm/4 3/4"
 one feestrated jaw



Crile-Wood
 DS-68-2905
 15 cm/5 7/8"



Crile-Murray
 DS-68-2906
 15 cm/5 7/8"
 slender pattern

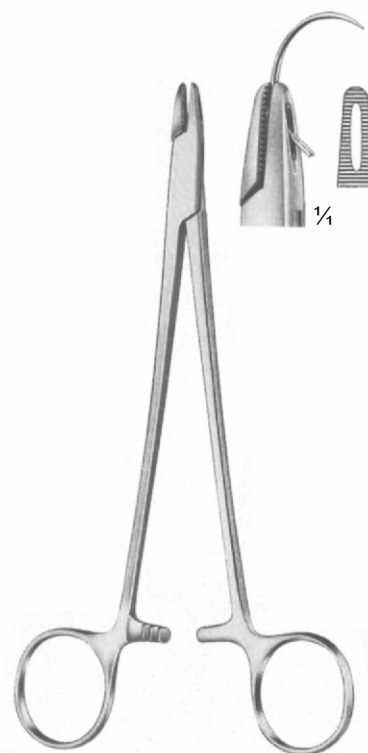

Adson
 DS-68-2907
 18 cm/7 1/8"
 one fenestrated jaw

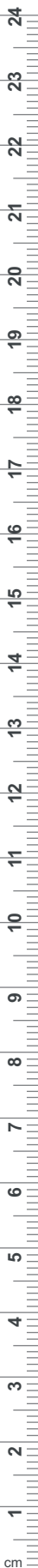

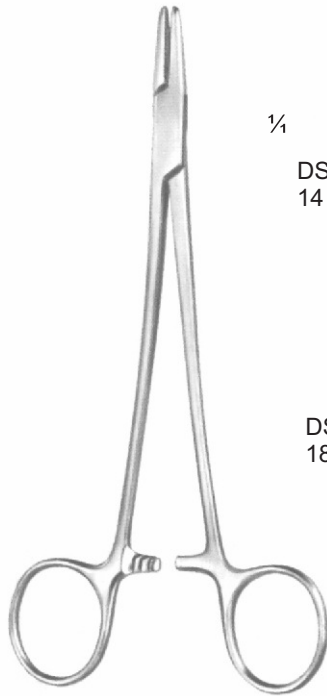

MAYO-HEGAR

1/4
 DS-68-2908
 14 cm/5 1/2"

DS-68-2909
 16 cm/6 1/4"

DS-68-2910
 18.5 cm/7 1/4"

DS-68-2911
 20.5 cm/8 1/8"

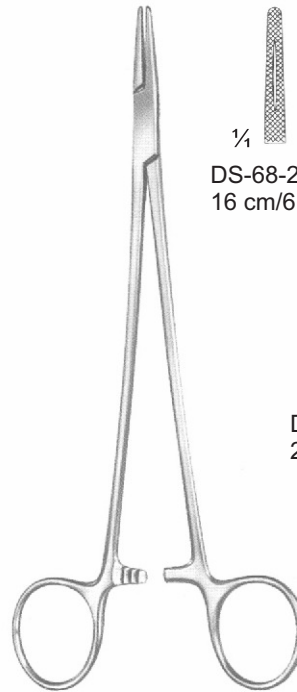

MAYO-HEGAR
 slender pattern

1/4
 DS-68-2912 DS-68-2913
 16 cm/6 1/4" 19 cm/7 1/2"

1/4
 DS-68-2914
 20.5 cm/8 1/8"



HEGAR-BAUMGARTNER
 DS-68-2915
 14 cm/5 1/2"



MATHIEU

1/4
 DS-68-2916 DS-68-2917
 14 cm/5 1/2" 17 cm/6 3/4"

DS-68-2918
 20 cm/7 7/8"



MATHIEU
 slender pattern

1/4
 DS-68-2919 DS-68-2920
 14 cm/5 1/2" 17 cm/6 3/4"

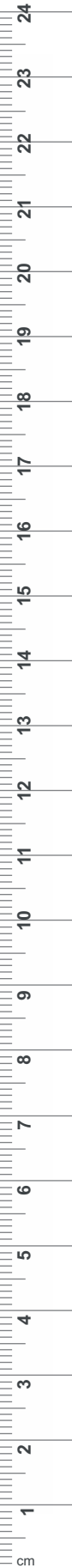



Lichtenberg
DS-68-2921
20 cm/7 7/8



Toennis
DS-68-2922
18.5 cm/7 1/4"



Crile
DS-68-2923
15 cm/5 7/8"

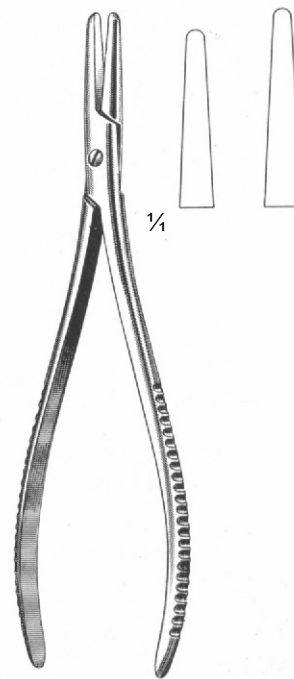

Langenbeck
DS-68-2924 16 cm/6 1/4"
DS-68-2925 20 cm/7 7/8"

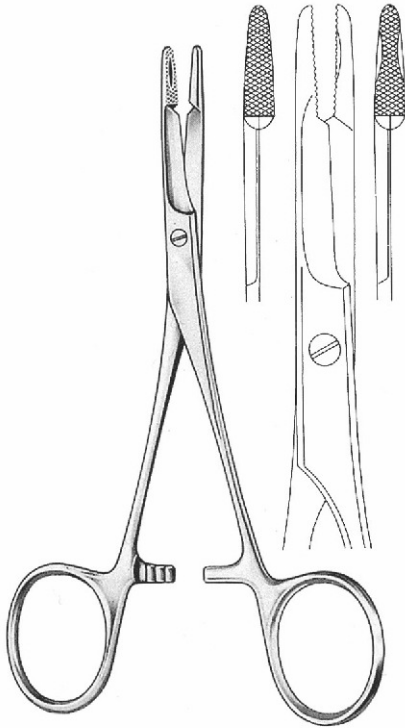

Olsen-Hegar

DS-68-2926 11 cm/4 3/8"

DS-68-2927 14 cm/5 1/2"

DS-68-2928 18 cm/7 1/8"

DS-68-2929 19 cm/7 1/2"

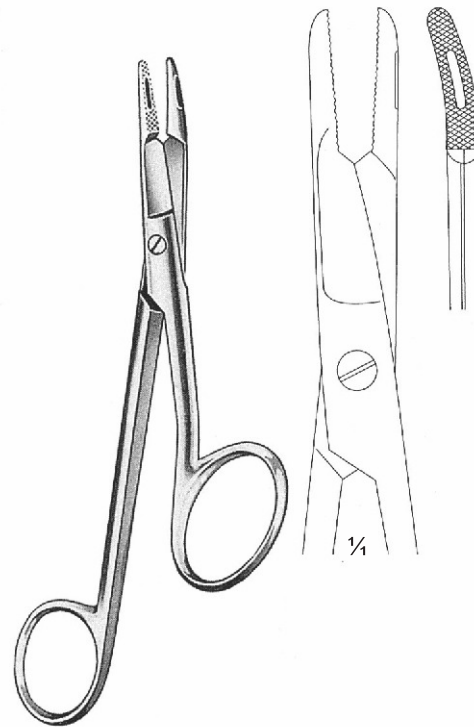

Gillies

DS-68-2930 Right hand

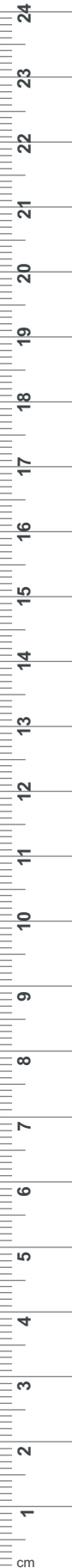
DS-68-2931 Left hand
16 cm/6 1/4"



DS-68-2932
 13 cm/5 1/8
 smooth jaw

HALSEY



DS-68-2933
 13 cm/5 1/8
 0.4 mm

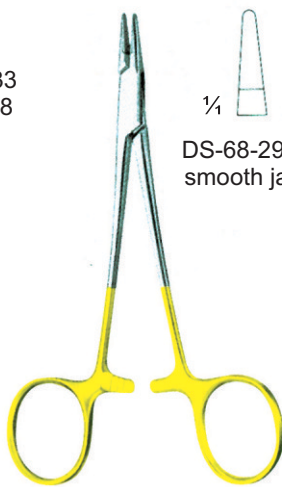

DS-68-2934
 smooth jaw

WEBSTER
 12.5 cm/4 7/8"



DS-68-2935
 0.4 mm



1/4
 0.4 mm

DERF
 DS-68-2936
 12 cm/4 3/4"



0.5 mm

Toennis
 DS-68-2937
 18 cm/7 1/8



0.5 mm
 DS-68-2938
 18.5 cm/7 1/4"



0.5 mm
 DS-68-2939
 20.5 cm/8 1/8



0.5 mm
 DS-68-2940
 23 cm/9"

Langenbeck

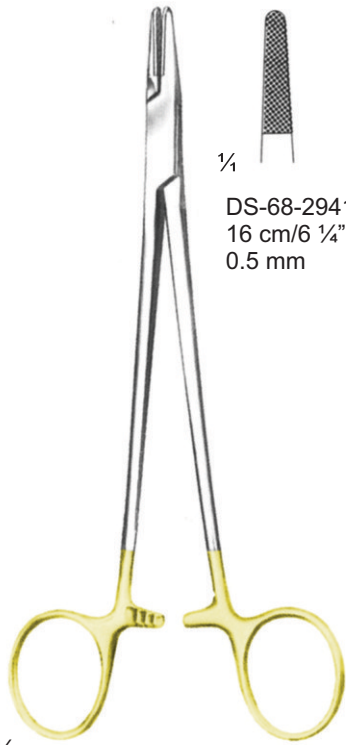

1/2

Mayo-Hegar
 standard profile

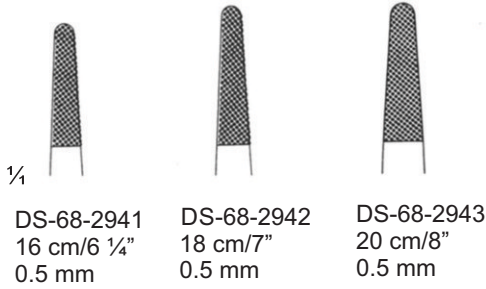

DS-68-2941
 16 cm/6 1/4"
 0.5 mm

DS-68-2942
 18 cm/7"
 0.5 mm

DS-68-2943
 20 cm/8"
 0.5 mm

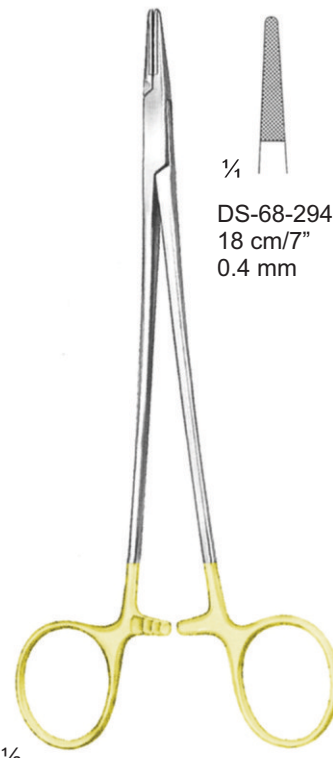

1/2

Debaquey
 mini profile

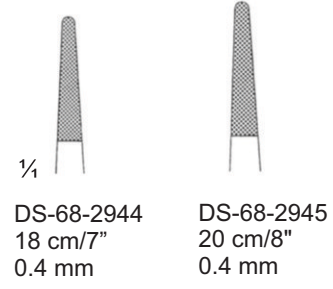

DS-68-2944
 18 cm/7"
 0.4 mm

DS-68-2945
 20 cm/8"
 0.4 mm



1/2

HEGAR-BAUMGARTNER

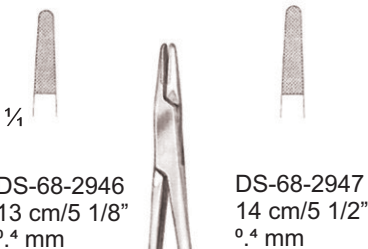

DS-68-2946
 13 cm/5 1/8"
 0.4 mm

DS-68-2947
 14 cm/5 1/2"
 0.4 mm



1/2

Mathieu
 Standard Profile

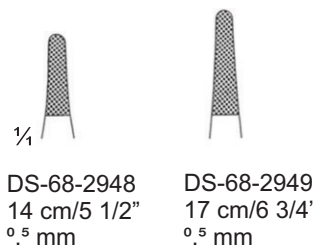

DS-68-2948
 14 cm/5 1/2"
 0.5 mm

DS-68-2949
 17 cm/6 3/4"
 0.5 mm



DS-68-2950
 20 cm/8"
 0.5 mm



1/2

Mathieu
 Standard Profile

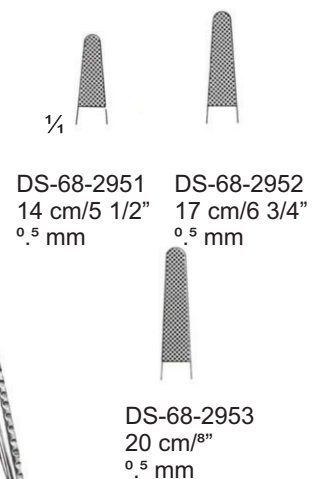

DS-68-2951
 14 cm/5 1/2"
 0.5 mm

DS-68-2952
 17 cm/6 3/4"
 0.5 mm

DS-68-2953
 20 cm/8"
 0.5 mm

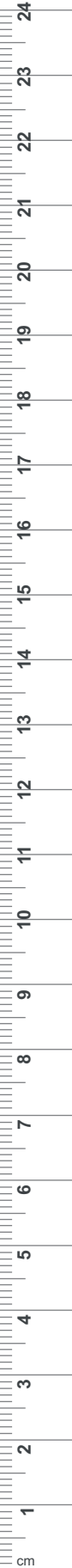



1/2

Mathieu



DS-68-2954	DS-68-2955	DS-68-2956
17 cm/6 3/4"	20 cm/8"	23 cm/9"
0.5 mm	0.5 mm	0.5 mm

with interior ratchet
 standard profile

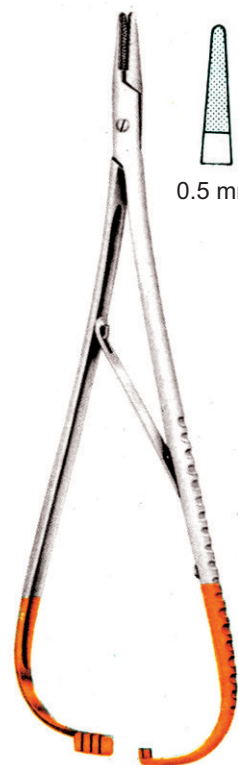

0.5 mm

Lichtenberg
 DS-68-2957
 20 cm/7 7/8"



1/2

Zweifel

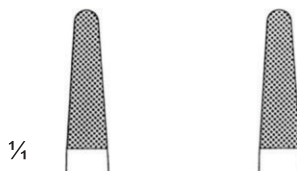

DS-68-2958	DS-68-2959
20.5 cm/8"	23 cm/9"
0.5 mm	0.5 mm

with hinged rehet
 Standard Profile

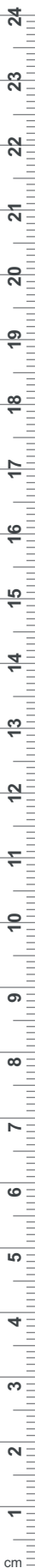

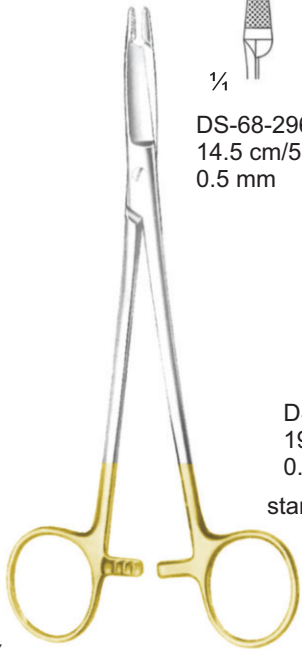
1/2

Olsen-Hegar

DS-68-2960
 14.5 cm/5 3/4"
 0.5 mm

DS-68-2961
 17 cm/6 3/4"
 0.5 mm

DS-68-2962
 19 cm/9 1/2"
 0.5 mm
 standard profile

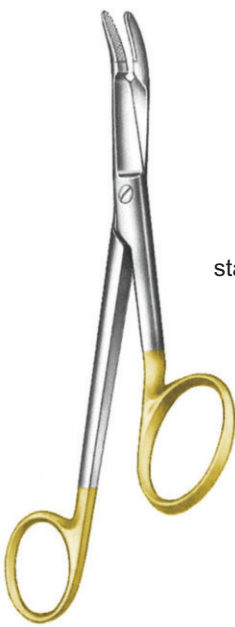

Gillies

DS-68-2963
 16 cm/6 1/4"
 0.5 mm
 standard profile



Foster-Gillies

DS-68-2964
 11 cm/4 1/4"
 smooth jaw



Gillies-Mini

DS-68-2965
 15 cm/6"
 0.4 mm
 mini profile





$\frac{1}{4}$ 
 DS-68-2966
 12 cm/4 $\frac{3}{4}$ "
 with lock

Castroviejo



$\frac{1}{4}$ 
 DS-68-2967
 12 cm/4 $\frac{3}{4}$ "
 with lock

Castroviejo



$\frac{1}{4}$ 
 DS-68-2968
 12.5 cm/5"
 with lock, smooth jaw

Castroviejo



$\frac{1}{4}$ 
 DS-68-2969
 14.5 cm/5 $\frac{3}{4}$ "
 with lock
 micro profile
 0.3 mm

Castroviejo

$\frac{1}{4}$ 
 DS-68-2970
 14.5 cm/5 $\frac{3}{4}$ "
 with lock
 micro profile
 0.3 mm

$\frac{1}{4}$ 
 DS-68-2971
 14.5 cm/5 $\frac{3}{4}$ "
 smooth jaw
 0.3 mm

$\frac{1}{4}$ 
 DS-68-2972
 18 cm/7"
 with lock
 micro profile
 0.3 mm

$\frac{1}{4}$ 
 DS-68-2973
 21.5 cm/8 $\frac{1}{2}$ "
 with lock
 micro profile
 0.3 mm

$\frac{1}{4}$ 
 DS-68-2974
 14.5 cm/5 $\frac{3}{4}$ "
 smooth jaw

$\frac{1}{4}$ 
 DS-68-2975
 18 cm/7"
 with lock
 micro profile
 0.3 mm

$\frac{1}{4}$ 
 DS-68-2976
 21.5 cm/8 $\frac{1}{2}$ "
 with lock
 micro profile
 0.3 mm

69

- EN** Retractors
- DE** Wundhaken
- ES** Ecarteurs

Page 144 to 148





Fig. 2 = 30 x 10 mm
 Fig. 1 = 26 x 10 mm

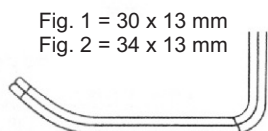
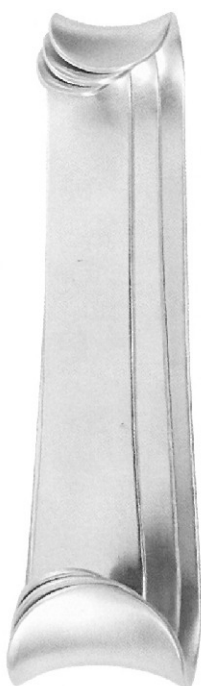

Fig. 1 = 30 x 13 mm
 Fig. 2 = 34 x 13 mm

FARABEU
 DS-69-3001
 12 cm/4 3/4"
 Fig. 1 - 2



ROUX
 DS-69-3002
 Set complete, Fig. 1- 3

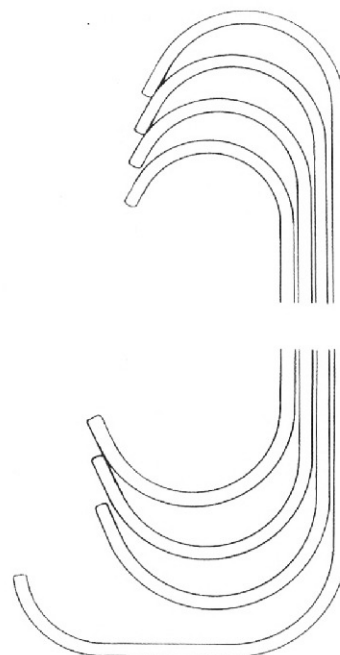
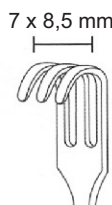

Fig. 1	14 cm/5 1/2"	DS-69-3003	24 x 20 / 30 x 28
Fig. 2	15 cm/6"	DS-69-3004	29 x 26 / 36 x 36
Fig. 3	17 cm/6 3/4"	DS-69-3005	23 x 29 / 38 x 43
Fig. 4	18 cm/7"	DS-69-3006	29 x 24 / 45 x 28



DS-69-3007
 sharp



DS-69-3008
 blunt

1/2

SENN
 17 cm/6 3/4"

sharp



16 cm/6 1/4"

DS-69-3009



DS-69-3010



DS-69-3011

sharp



1/2

16 cm/6 1/4"

DS-69-3012



DS-69-3013



DS-69-3014

DS-69-3015
 18 cm/7"
 Fig. 1

small curvature

DS-69-3016
 18 cm/7"
 Fig. 2

large curvature

1/2

GILLIES
 18 cm/7"

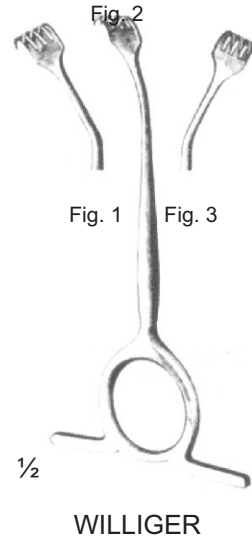
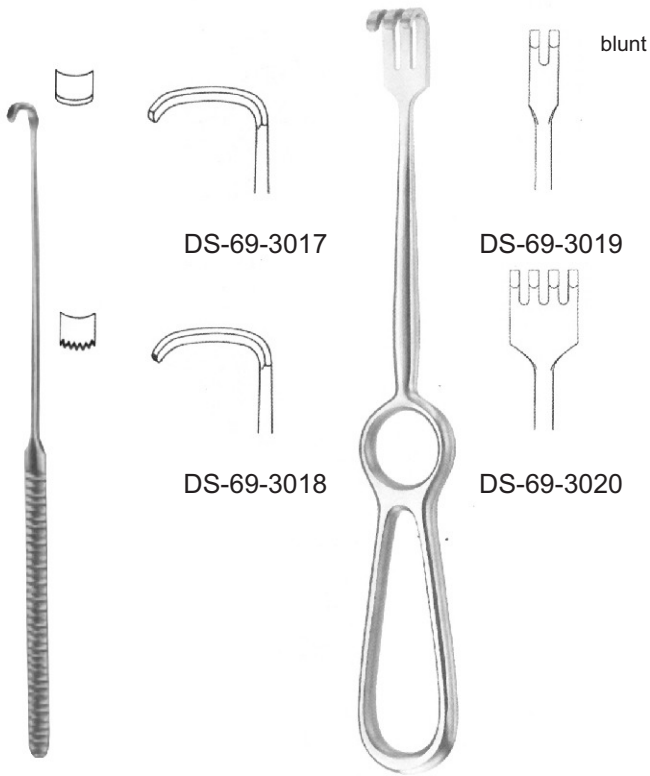
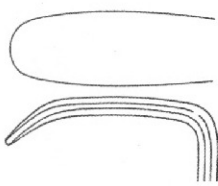

Fig. 1 DS-69-3021 DS-69-3024
 Fig. 2 DS-69-3022 DS-69-3025
 Fig. 3 DS-69-3023 DS-69-3026

STRANDELL-STILLE
 19, cm/7 1/2"

VOLKMANN
 21,5 cm/8 1/2"



DS-69-3027
 30x 11 mm

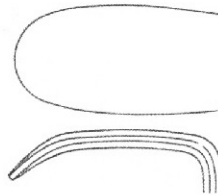

DS-69-3029
 30x 16 mm

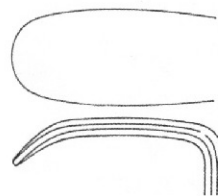

DS-69-3028
 30x 14 mm

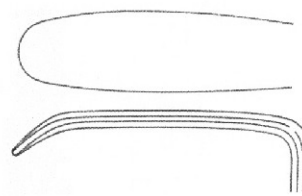

DS-69-3030
 40x 11 mm

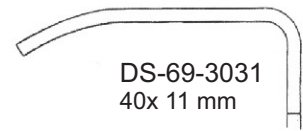

DS-69-3031
 40x 11 mm

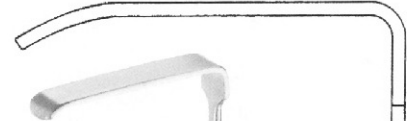

DS-69-3032
 55x 11 mm

LANGENBECK
 22 cm/8 3/4"

KOCHER-LANGENBECK
 22 cm/8 1/2"



MIDDELDORPF

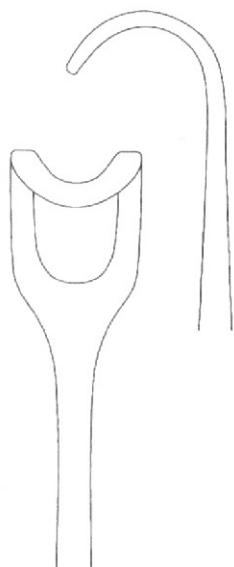

DS-69-3033
21,5 cm/8 1/2"
14 x 17 mm

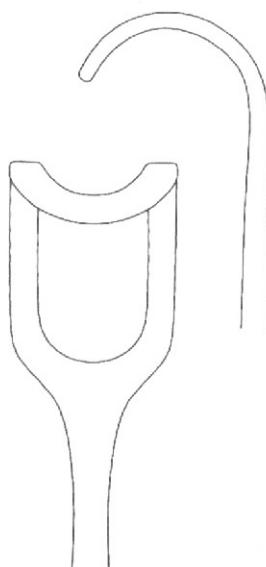

DS-69-3034
22 cm/8 3/4"
20 x 22 mm



KOCHER LANGENBECK
DS-69-3035
21 cm/8 1/4"
23 x 8 mm



WARD
DS-69-3036
15,5 cm/6"

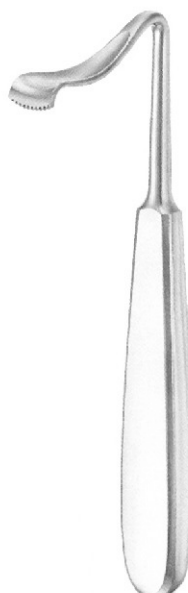

BOWDLER=HENRY
DS-69-3037
16 cm/6 1/4"



KAY (AUSTIN)
DS-69-3038

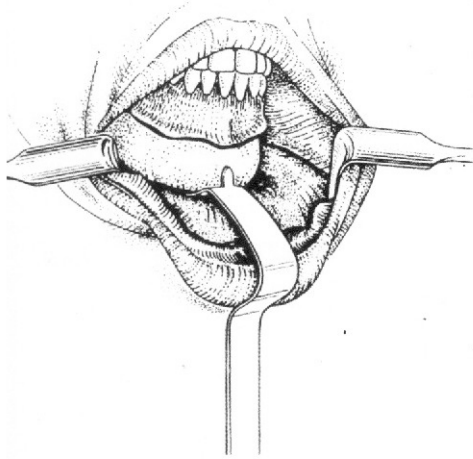

16,5 mm

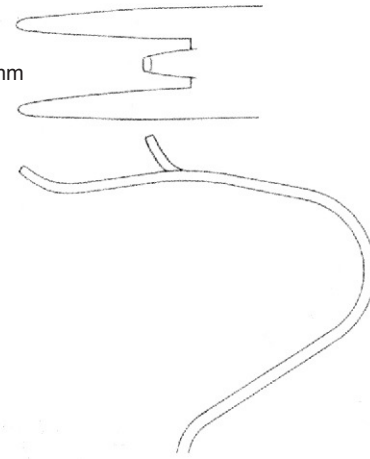

OBWEGESER
 DS-69-3039
 16 cm/6 1/4"

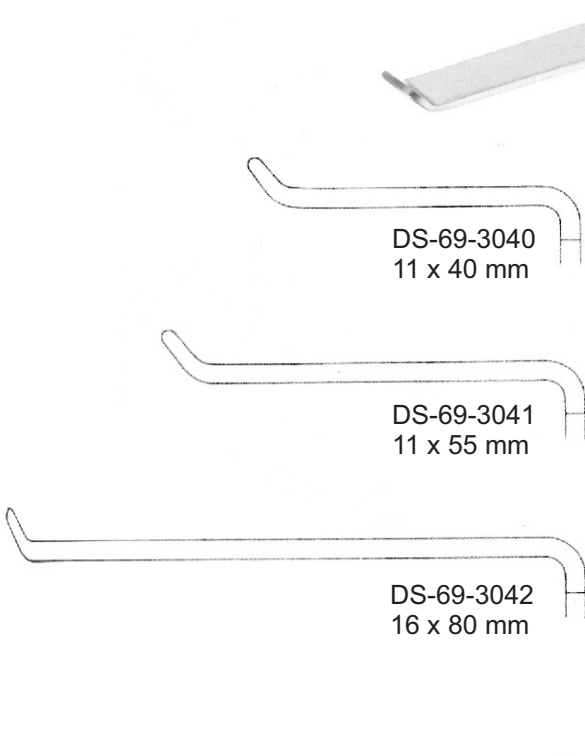

DS-69-3040
 11 x 40 mm

DS-69-3041
 11 x 55 mm

DS-69-3042
 16 x 80 mm

OBWEGESER
 21,5 cm/8 1/2"

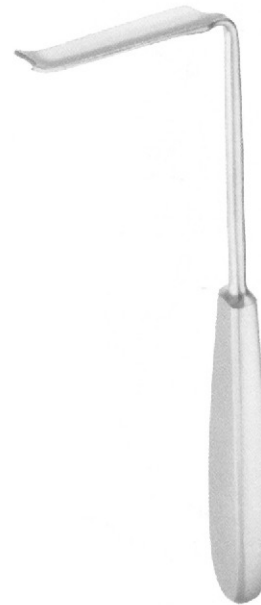

DS-69-3043
 30 x 9/12 mm

DS-69-3044
 45 x 9/12 mm

DS-69-3045
 60 x 9/12 mm

OBWEGESER

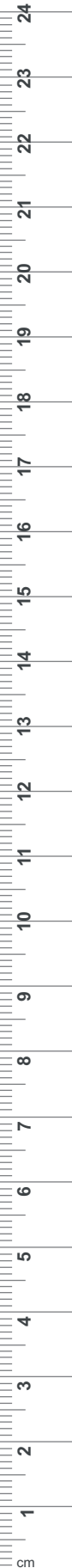

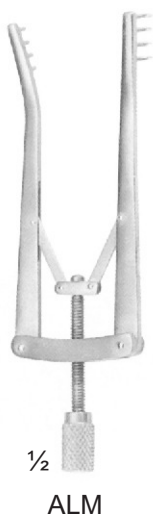
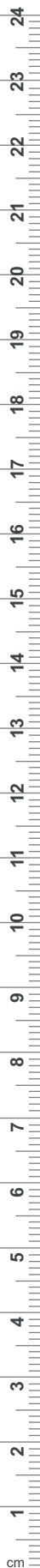

DS-69-3046
7 cm/2 3/4"
sharp

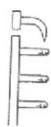

DS-69-3047
10 cm/4"
sharp

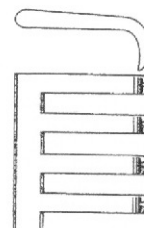
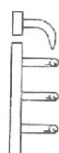

DS-69-3048
13 cm/4 1/4"
3 : 4
sharp

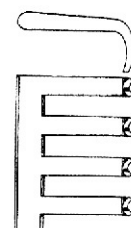

DS-69-3049
13 cm/4 1/4"
3 : 4
blunt

70

EN Mouth and Tongue

DE Mund und Zunge

ES Boca y la lengua

Page 149 to 152

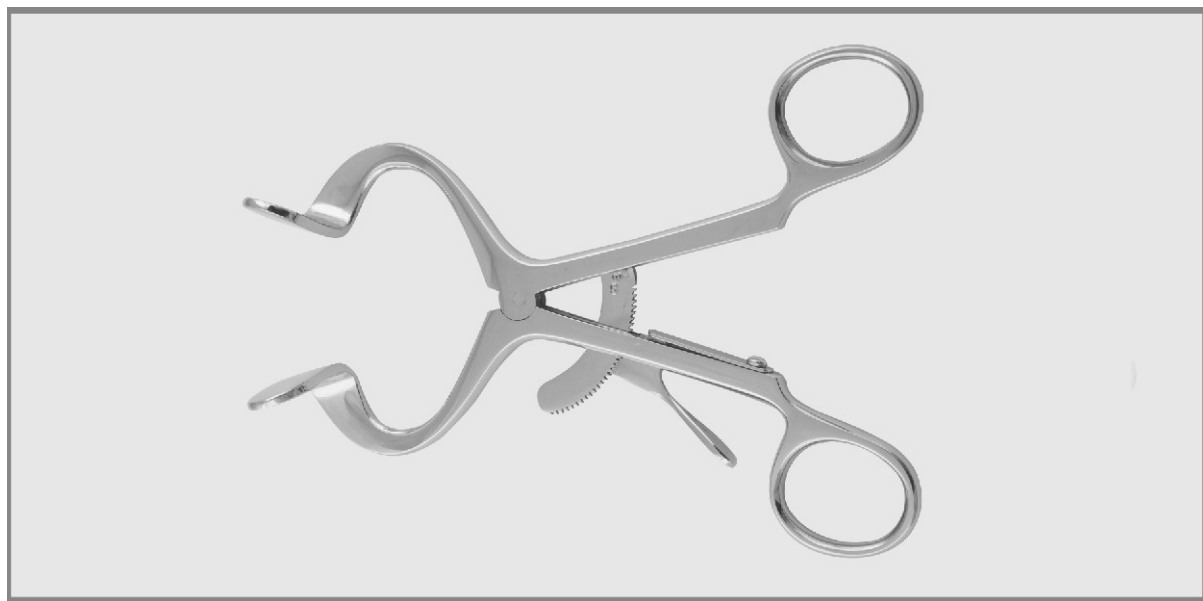



DOYEN-JANSEN (MOLT)
 DS-70-3100 9 cm/3 ½"
 DS-70-3101 11 cm/4 ½"
 DS-70-3102 14 cm/5 ½"



DENHARDT
 DS-70-3103
 12 cm/5"



HEISTER
 DS-70-3104
 13 cm/5 ¼"



ROSIER-KOENIG
 16 cm/6 ¼" DS-70-3105
 19 cm/7 ½" DS-70-3106



JENNINGS
 9 cm/3 ½" DS-70-3107
 11 cm/4 ½" DS-70-3108
 13 cm/5" DS-70-3109
 15 cm/6" DS-70-3110



COLLIN
 DS-70-3111
 16 cm/6 ½"



YOUNG
 DS-70-3112
 16 cm/6 ½"

DS-70-3113

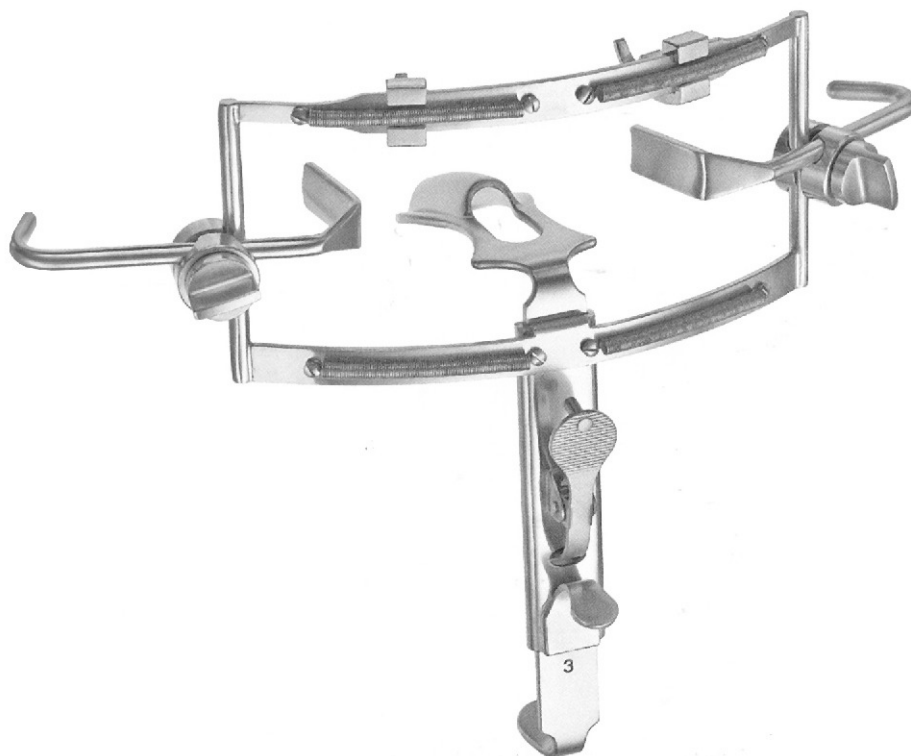

complete with frame,
3 tongue depressors,
2 tooth plates

DINGMANN
DS-70-3114
14,5 cm/5 3/4"

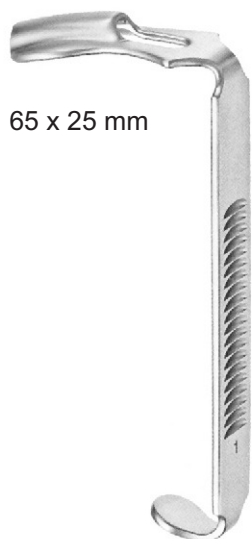

65 x 25 mm

DS-70-3115
13,5 cm/5 1/4"

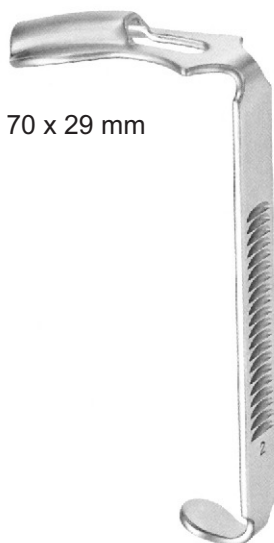

70 x 29 mm

DS-70-3116
13,5 cm/5 1/4"



80 x 32 mm

DS-70-3117
13,5 cm/5 1/4"





DS-70-3118
16 cm/6 1/4"

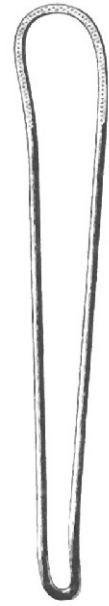

FRENZEL
DS-70-3119
16,5 cm/6 1/2"

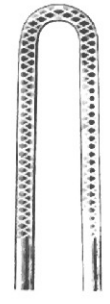

19 / 15 mm

BRUENINGS
DS-70-3120
19 cm/7 1/2"



BUCHWALD
DS-70-3121
19 cm/7 1/2"

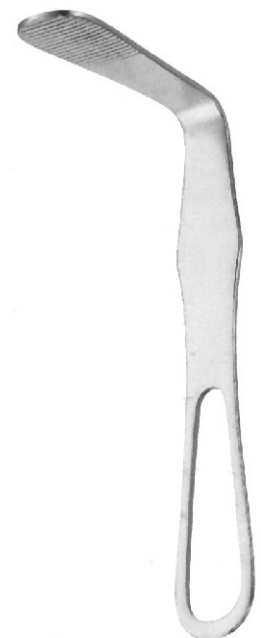

HARTMANN
DS-70-3122
15 cm/6"

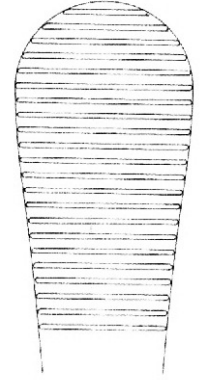

72 X 23 mm



24 / 30 mm

DS-70-3123
13,5 cm/5 1/4"

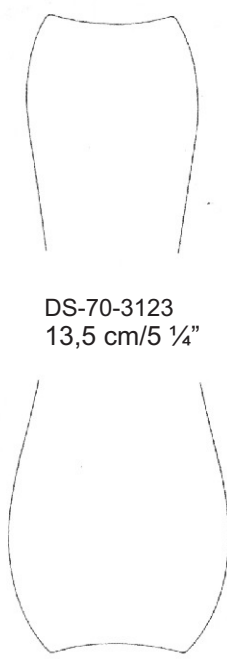

30 / 34 mm

DS-70-3124
16 cm/6 1/4"

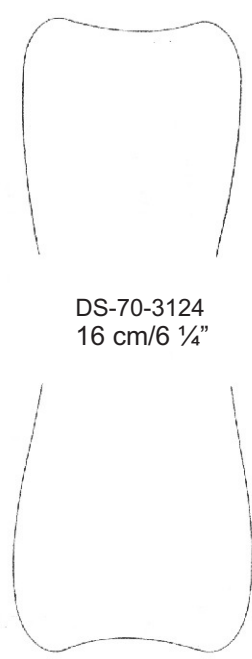

WIEDER

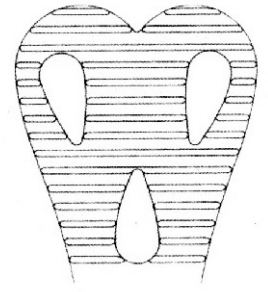

DS-70-3125
14 cm/5 1/2"
36 mm

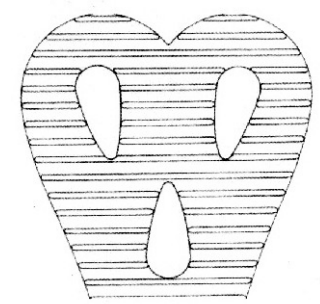

DS-70-3126
15 cm/6"
43 mm



85 x 24 mm

TOBOLD
 DS-70-3127
 14,5 cm/5 3/4"

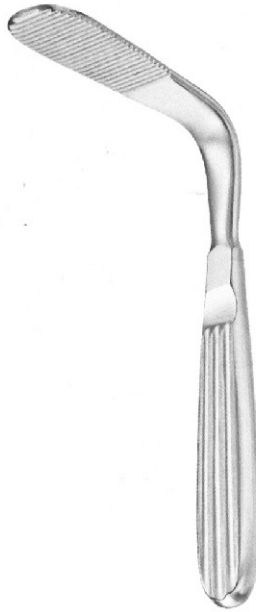

88 x 25 mm

TOBOLD
 DS-70-3128
 15 cm/6"

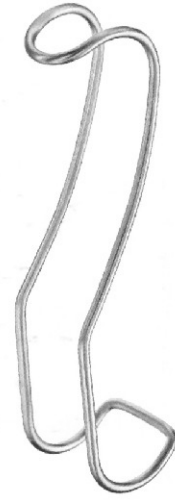

STERNBERG
 DS-70-3129
 14 cm/5 1/2"



SIMPLEX
 DS-70-3130
 11 cm/4 1/4"



CAWOOD-MINNESOTA
 DS-70-3131
 14 cm/5 1/2"

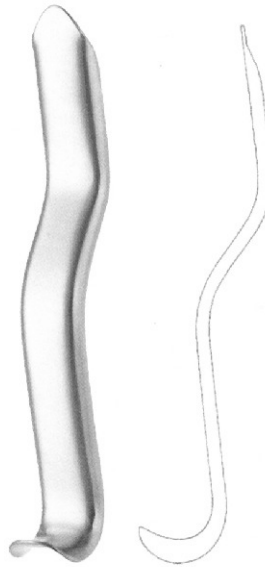

CAWOOD-MINNESOTA
 DS-70-3132
 15 cm/6"
 20 mm

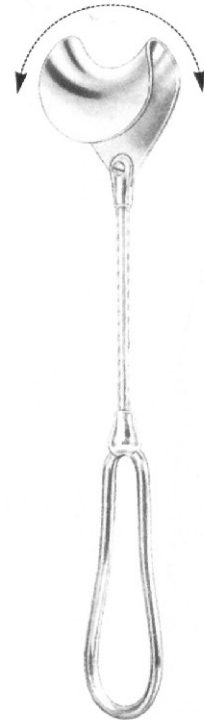

DS-70-3133
 19 cm/7 1/2"

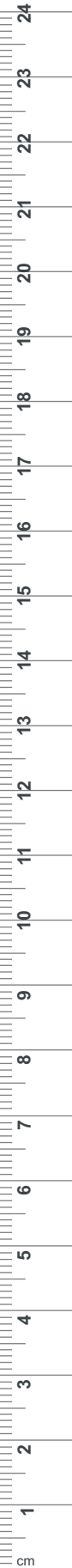

71

EN Scissors

DE Schere

ES Tijeras

Page 153 to 171

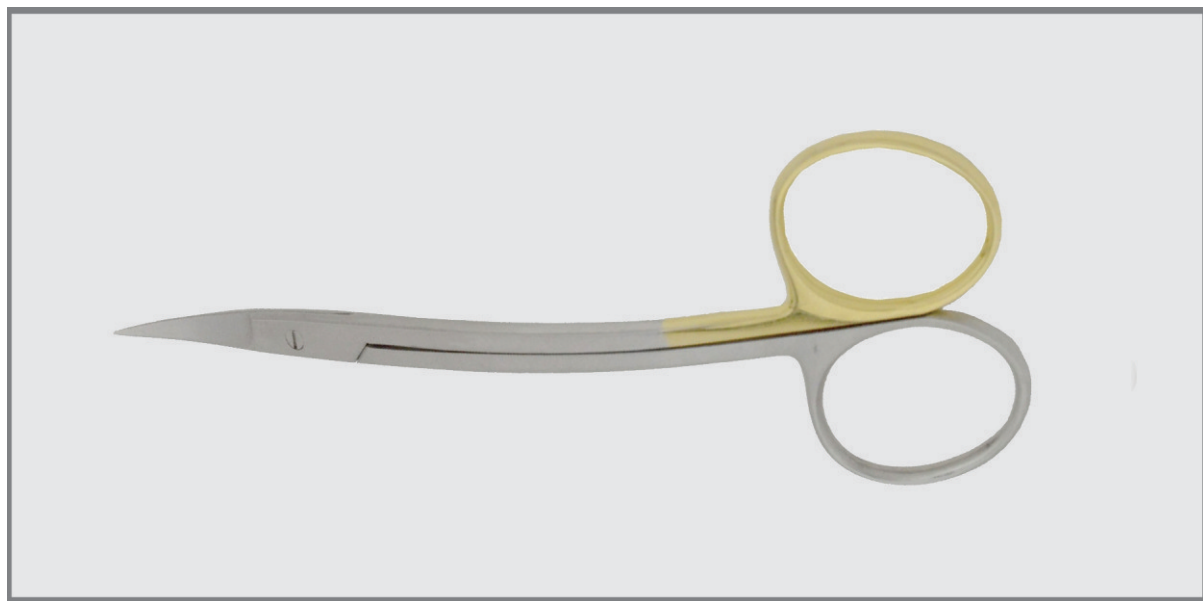

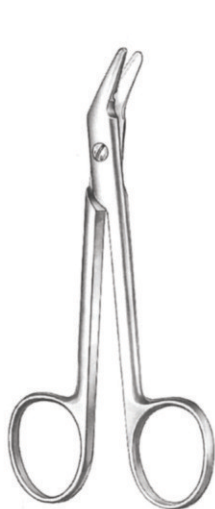

DS-71-3200
universal
12 cm/4 3/4"

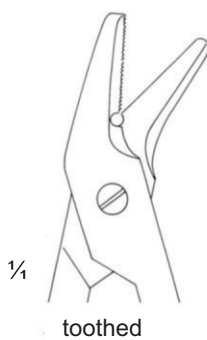

DS-71-3201 TC
universal
12 cm/4 3/4"

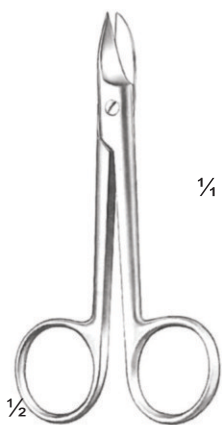

Beebee
10.5 cm/4 1/8"

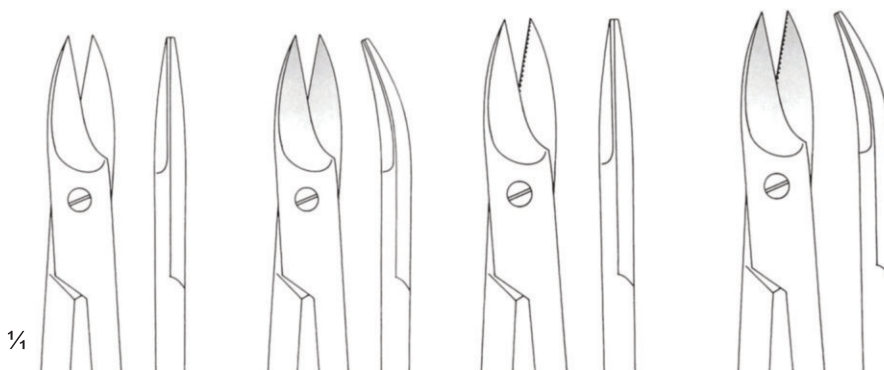

DS-71-3202
B-002-10 TC

DS-71-3203
B-003-10 TC

DS-71-3204
B-004-10 TC

DS-71-3205
B-005-10 TC

one toothed cutting edge



Beebee
10.5 cm/4 1/8"



1/2
 Standard
 14.5 cm/5 3/4

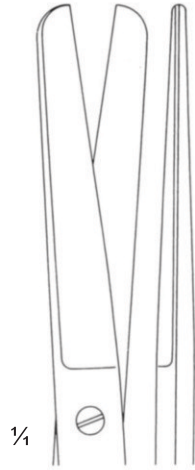

1/4
 DS-71-3206
 DS-71-3207 TC



1/4
 DS-71-3208
 DS-71-3209 TC



1/4
 DS-71-3210
 DS-71-3211 TC



1/2
 Standard
 14.5 cm/5 3/4



1/2
 Standard
 14.5 cm/5 3/4



1/4
 DS-71-3212
 DS-71-3213 TC



1/4
 DS-71-3214
 DS-71-3215 TC



1/4
 DS-71-3216
 DS-71-3217 TC



1/2
 Standard
 14.5 cm/5 3/4

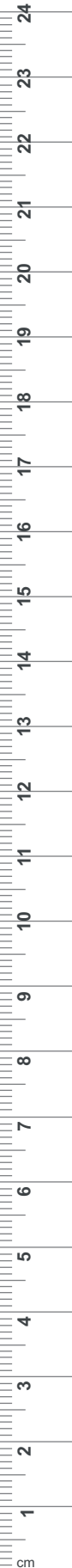

DELICATE

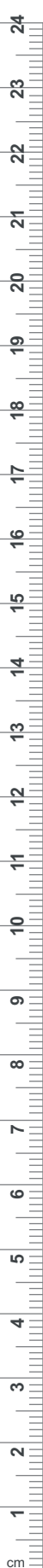
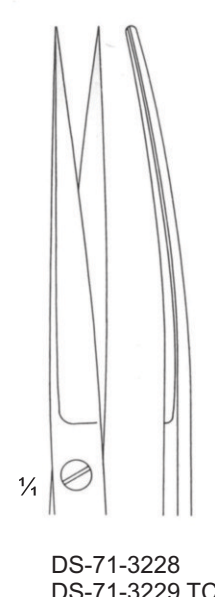
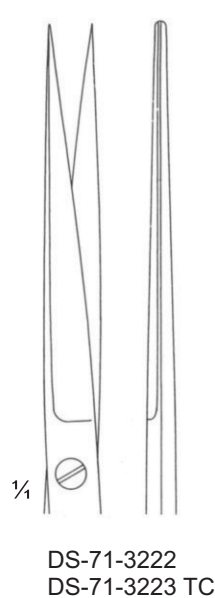
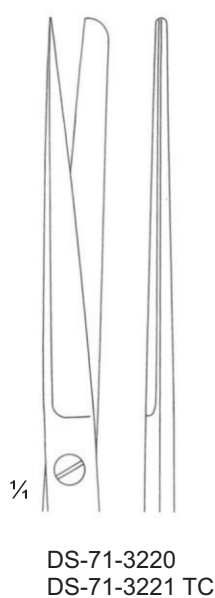
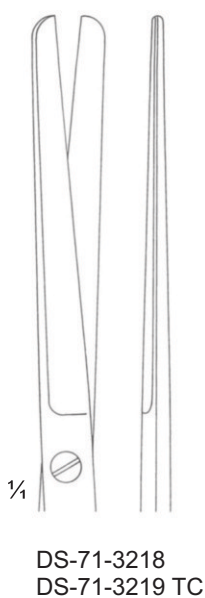

Wire Cutting Scissors ●— EN
 Drahtscheren ●— DE
 Tijeras para alambre ●— ES

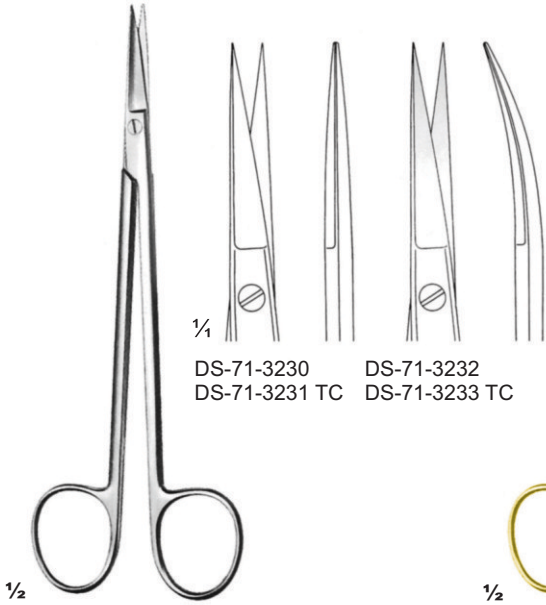

Kelly
16 cm/6 1/4"

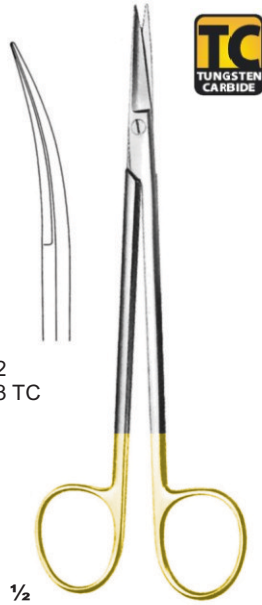

Kelly
16 cm/6 1/4"

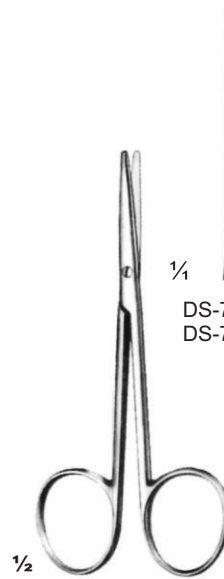

Metzenbaum
11.5 cm/4 1/2"



Metzenbaum
11.5 cm/4 1/2"



Metzenbaum
14 cm/5 1/2"

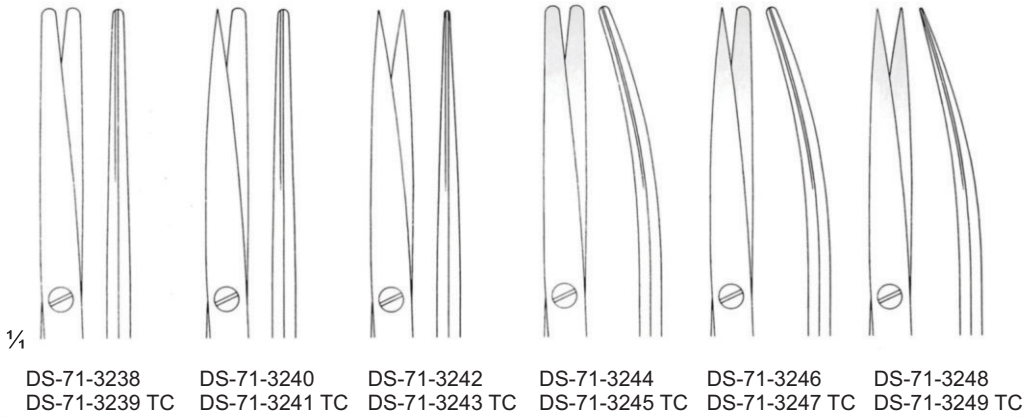

Metzenbaum
14 cm/5 1/2"



DELICATE



Metzenbaum
15.5 cm/6"

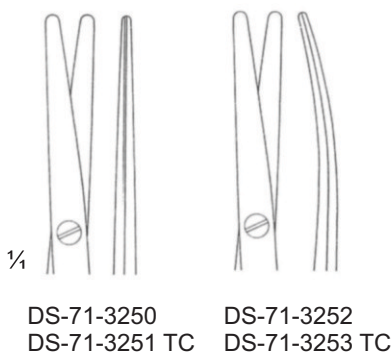

DS-71-3250 DS-71-3252
DS-71-3251 TC DS-71-3253 TC



Metzenbaum
15.5 cm/6"



Metzenbaum-Nelson
18 cm/7"

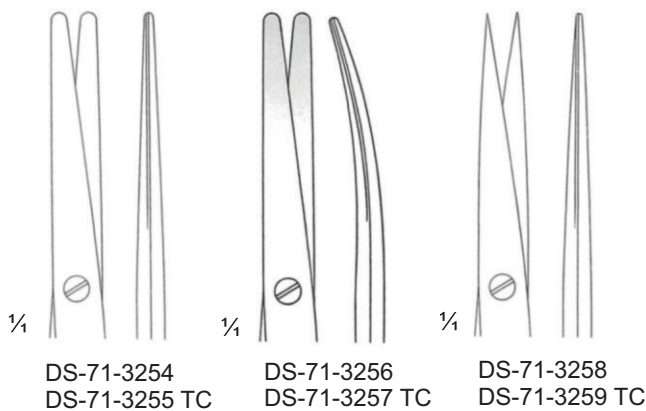

DS-71-3254 DS-71-3256 DS-71-3258
DS-71-3255 TC DS-71-3257 TC DS-71-3259 TC

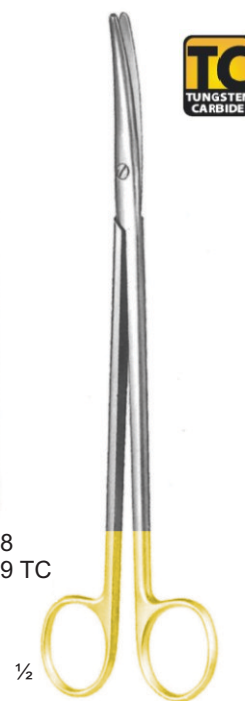

Metzenbaum-Nelson
18 cm/7"

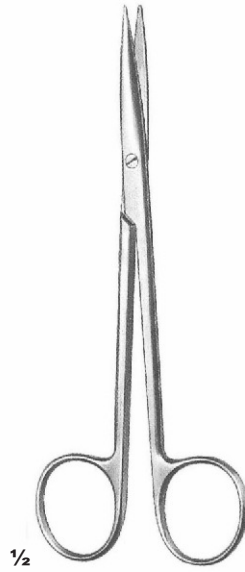

Metzenbaum
14.5 cm/5 3/4"

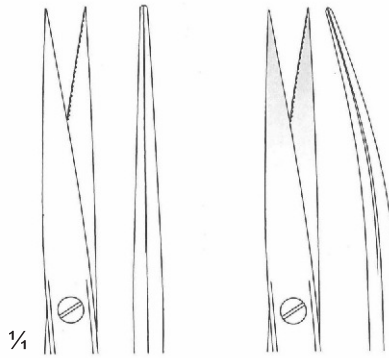

DS-71-3260

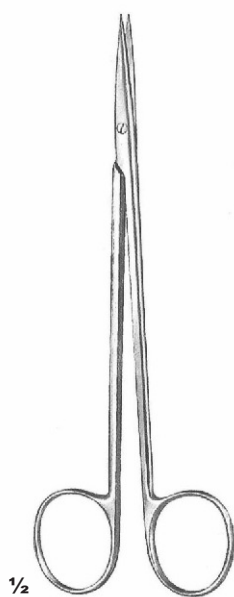

Nerve dissecting scissors
15.5 cm/6"

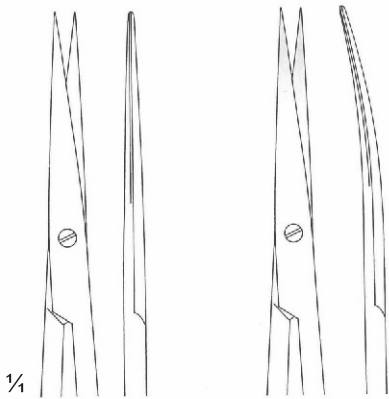

DS-71-3262

DS-71-3263

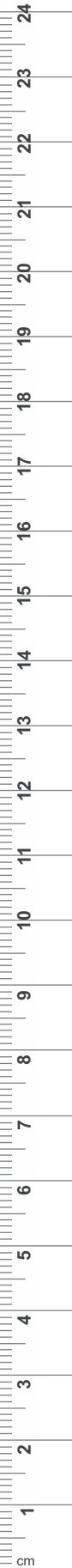



Lexer-Fino
slender pattern
16.5 cm/6 1/2"

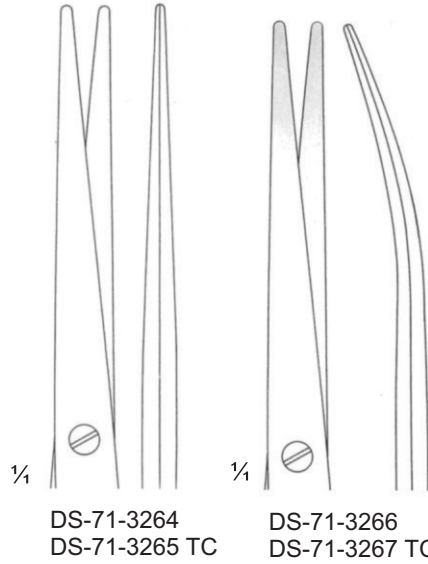

DS-71-3264
DS-71-3265 TC

DS-71-3266
DS-71-3267 TC



Lexer-Fino
slender pattern
16.5 cm/6 1/2"



Metzenbaum-Fino
slender pattern
14.5 cm/5 3/4"

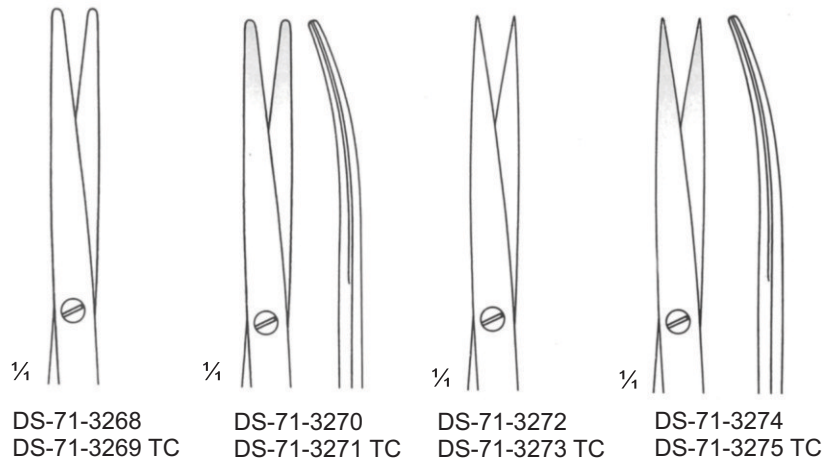

DS-71-3268
DS-71-3269 TC

DS-71-3270
DS-71-3271 TC

DS-71-3272
DS-71-3273 TC

DS-71-3274
DS-71-3275 TC



Metzenbaum-Fino
slender pattern
14.5 cm/5 3/4"



Metzenbaum-Fino
slender pattern
18 cm/7"



DS-71-3276
DS-71-3277 TC

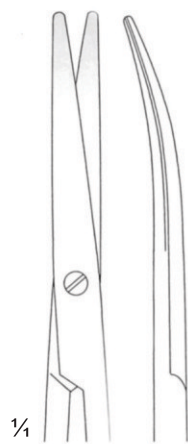

DS-71-3278
DS-71-3279 TC



Metzenbaum-Fino
slender pattern
18 cm/7"



Metzenbaum-Fino
S shaped
18 cm/7"



DS-71-3280
DS-71-3281 TC



Metzenbaum-Fino
S shaped
18 cm/7"



DS-71-3282
12.5 cm/5"



DS-71-3283
18 cm/7"

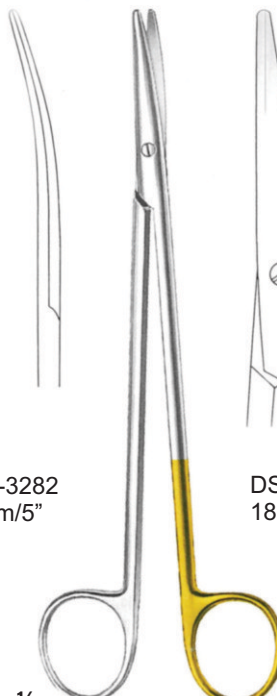

Salyer
fine model for cleft palate

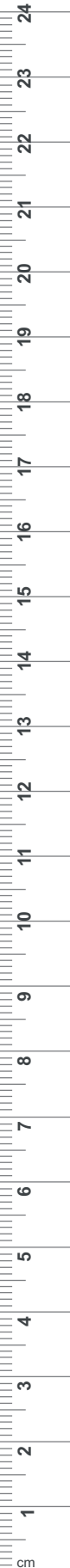

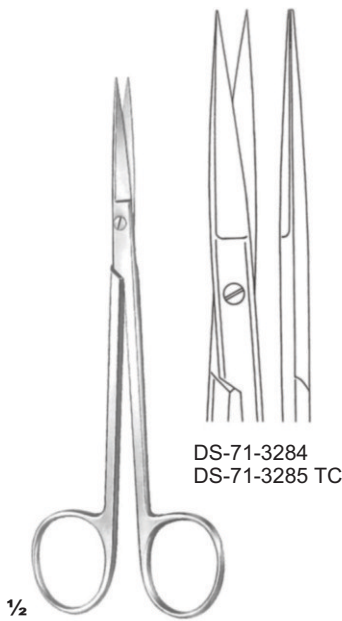
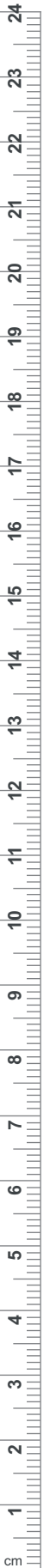

Sanvenero
14 cm/5 1/8"

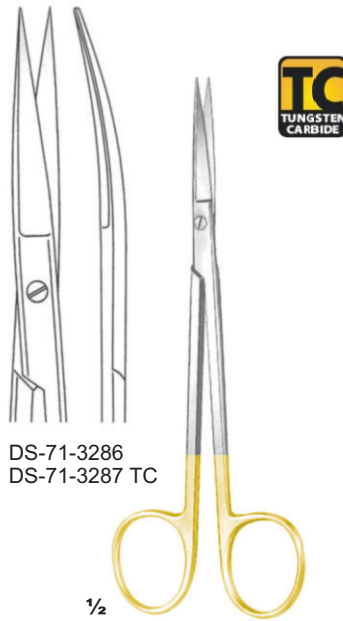

Sanvenero
14 cm/5 1/8"

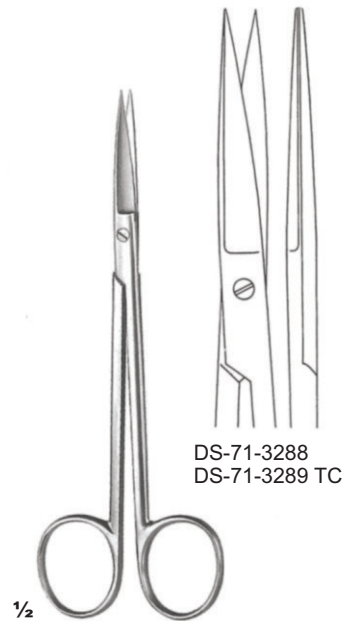

Joseph
14.5 cm/5 3/4"

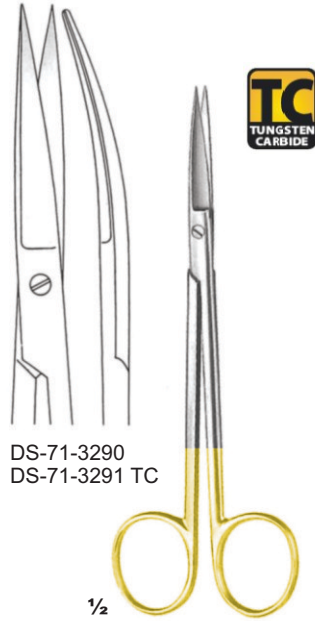

Joseph
14.5 cm/5 3/4"

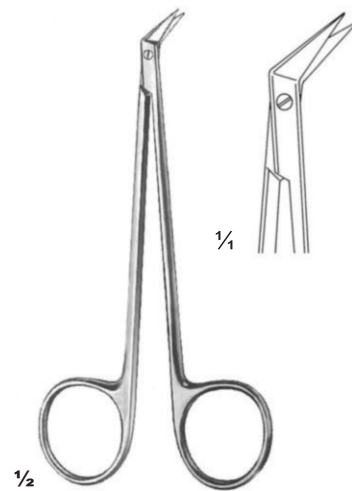

Diethrich-Salyer
DS-71-3292
12 cm/4 3/4"

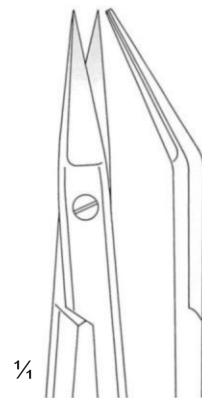

DS-71-3293
angled upwards



Dean
17.5 cm/7"



DS-71-3294
toothed, angled upwards

Gum scissors, operating scissors — EN
 Zahnfleissscheren, chirurgische scheren — DE
 Tijeras para encías, Tijeras quirúrgicas — ES



DS-71-3295
 DS-71-3296 TC

GOLDMANN-FOX
 13 cm/5 1/8"



DS-71-3297
 DS-71-3298 TC

GOLDMANN-FOX
 13 cm/5 1/8"

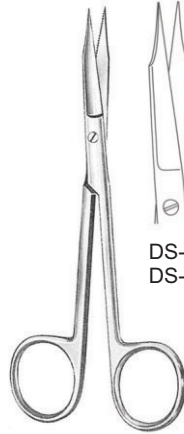

DS-71-3299
 DS-71-3300 TC

GOLDMANN-FOX
 13 cm/5 1/8"



DS-71-3301
 DS-71-3302 TC

Toothed Blades



GOLDMANN-FOX
 13 cm/5 1/8"

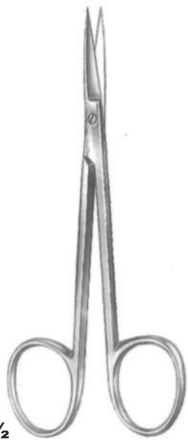

Small modle
 12 cm/4 3/4"

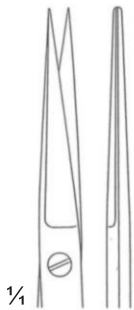

DS-71-3303



DS-71-3304



DS-71-3305



slender pattern
 DS-71-3306
 DS-71-3307 TC



Toennis-Adson
 17.5 cm/7"



Toennis-Adson
 17.5 cm/7"



1/2
 La Grange
 11.5 cm/4 1/2"

DS-71-3308
 S shaped



1/2
 Delicate
 11.5 cm/4 1/2"

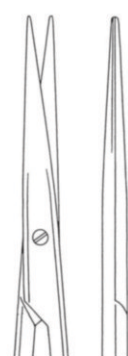

DS-71-3309



DS-71-3310

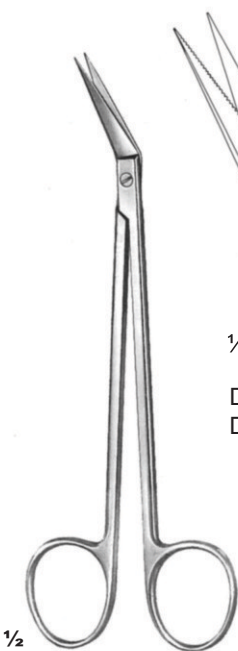

1/2
 Locklin
 16 cm/6 1/4"



1/4
 DS-71-3311
 DS-71-3312 TC

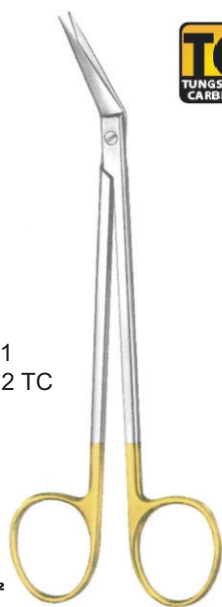

1/2
 Locklin
 16 cm/6 1/4"



1/2
 Locklin
 16 cm/6 1/4"

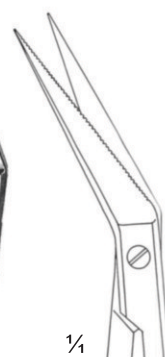

1/4
 DS-71-3313
 DS-71-3314 TC



1/2
 Locklin
 16 cm/6 1/4"



one toothed cutting edge

one toothed cutting edge

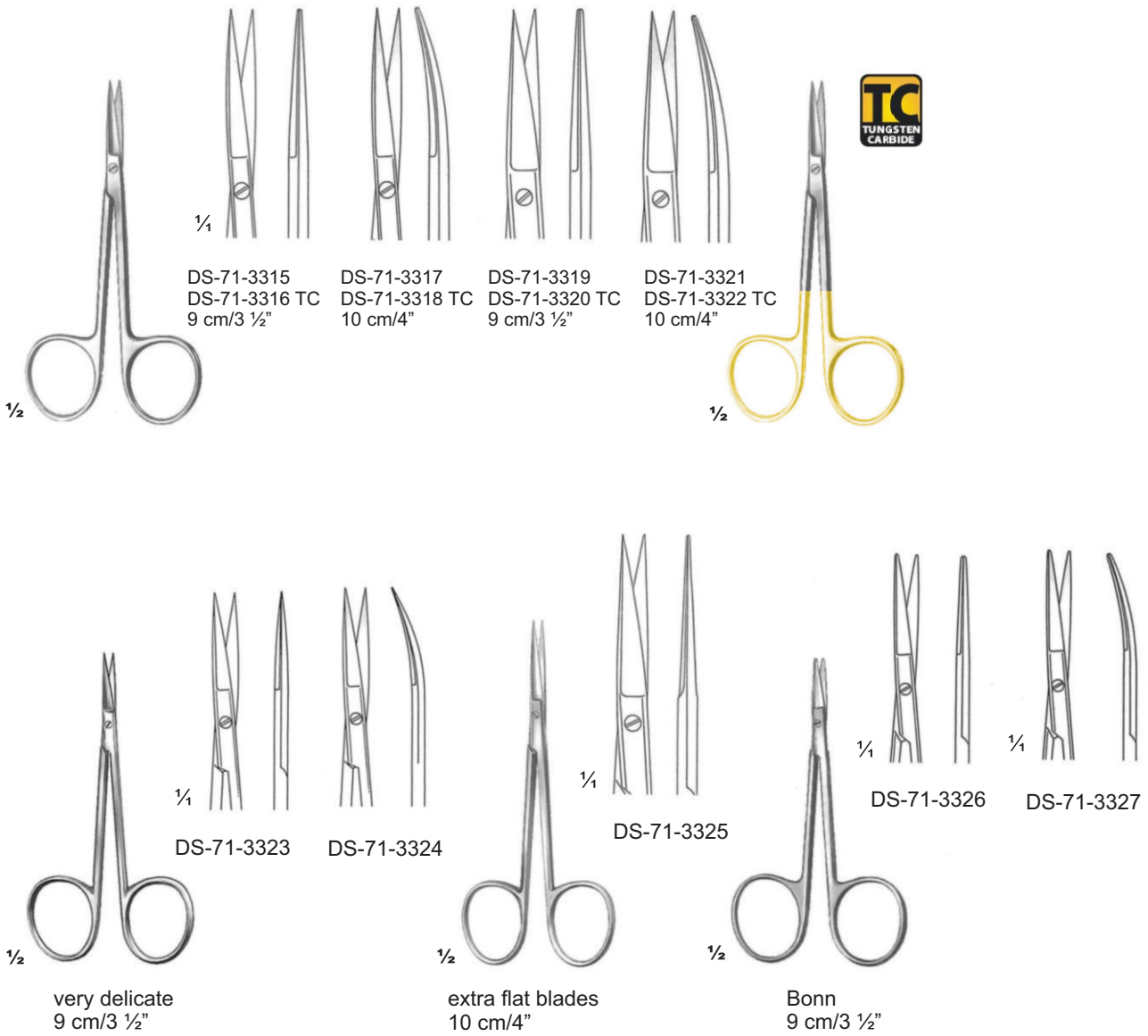



11.5 cm/4 1/2"

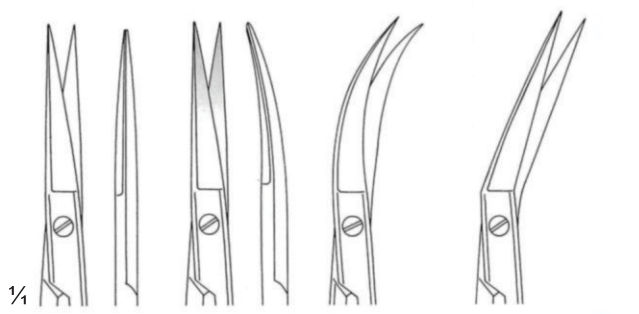

DS-71-3328 DS-71-3330 DS-71-3332 DS-71-3334
 DS-71-3329 TC DS-71-3331 TC DS-71-3333 TC DS-71-3335 TC



11.5 cm/4 1/2"

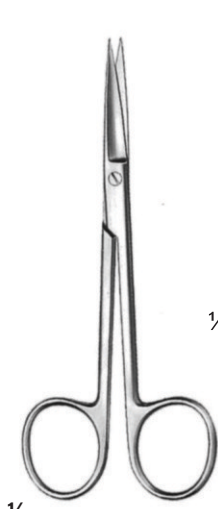

12.5 cm/5"

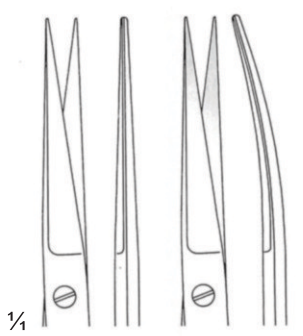

DS-71-3336 DS-71-3337



Stevens
 11 cm/4 1/2"

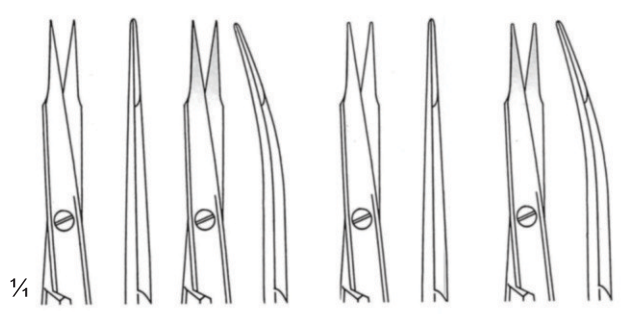

DS-71-3338 sharp DS-71-3339 sharp DS-71-3340 blunt DS-71-3341 blunt

Stitch scissors — EN
 Fadenscheren — DE
 Tijeras para hilos — ES

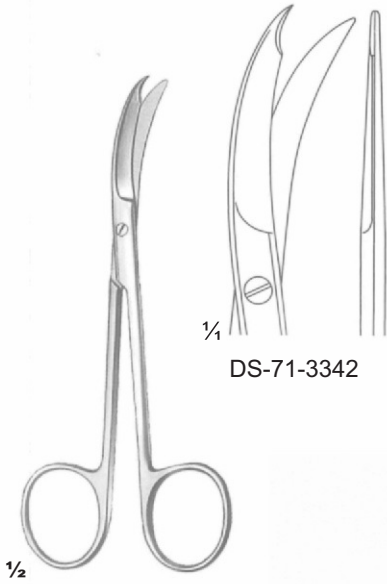

DS-71-3342

Northbent
13 cm/5"



DS-71-3343
9 cm/3 1/2"

Spencer

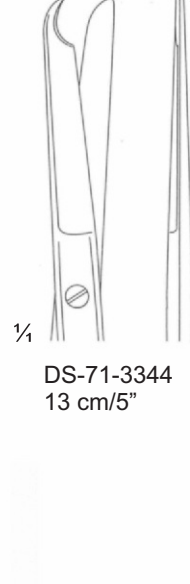

DS-71-3344
13 cm/5"

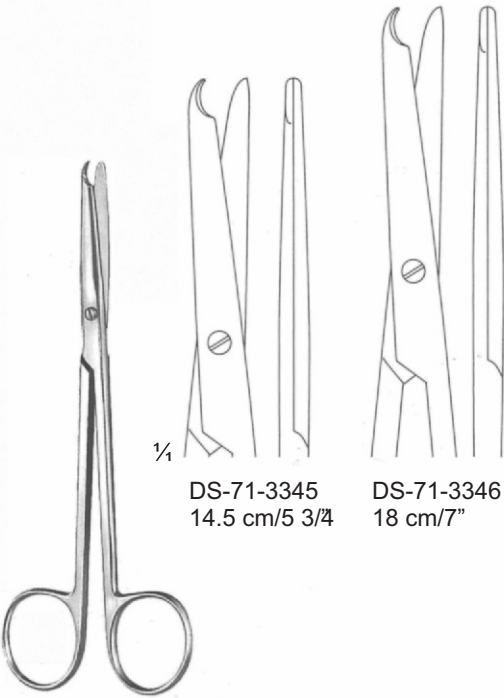

DS-71-3345
14.5 cm/5 3/4"

Buck

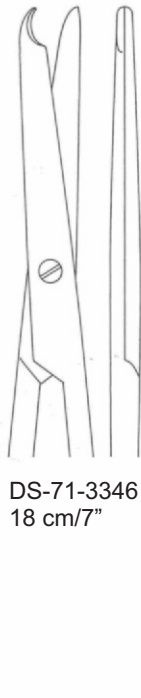

DS-71-3346
18 cm/7"

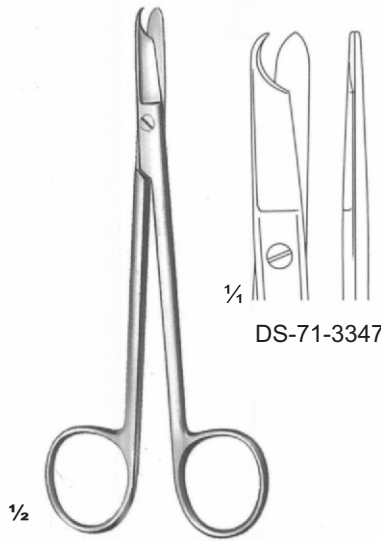

DS-71-3347

Littauer
14 cm/5 1/2"

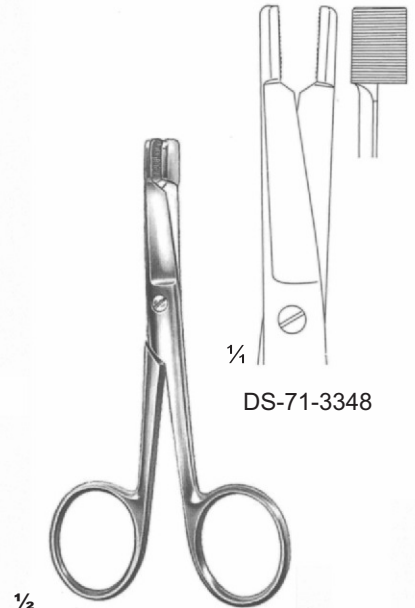

DS-71-3348

Eiselsberg
12 cm/4 3/4"



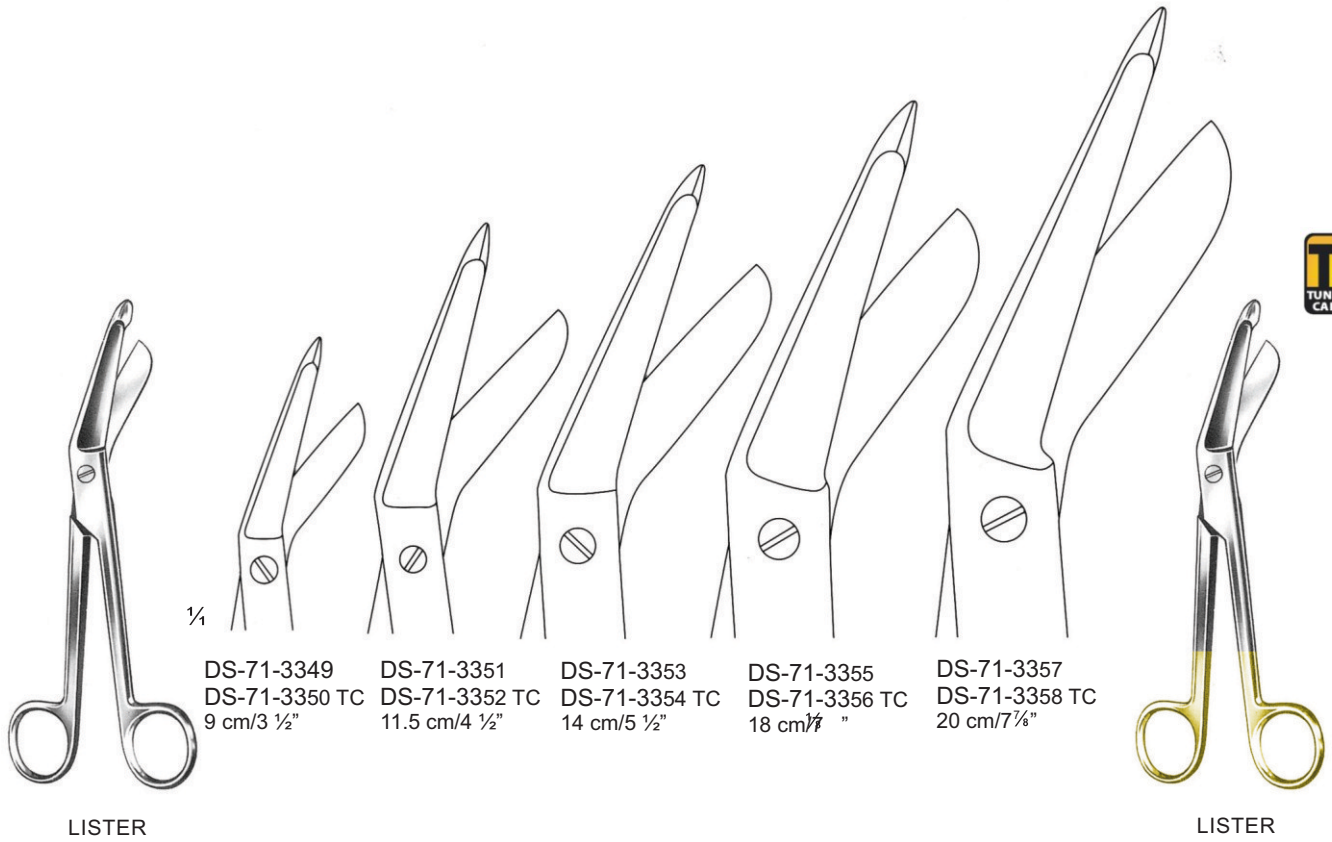

DS-71-3349
 DS-71-3350 TC
 9 cm/3 1/2"

DS-71-3351
 DS-71-3352 TC
 11.5 cm/4 1/2"

DS-71-3353
 DS-71-3354 TC
 14 cm/5 1/2"

DS-71-3355
 DS-71-3356 TC
 18 cm/7"

DS-71-3357
 DS-71-3358 TC
 20 cm/7 1/4"

LISTER

LISTER



DS-71-3359
 DS-71-3360 TC

DS-71-3361
 DS-71-3362 TC

Wagner
 12 cm/4 3/4"

Wagner
 12 cm/4 3/4"

Delicate dissecting scissors — EN
 Feine präparierscheren — DE
 Tijeras finas de disección — ES

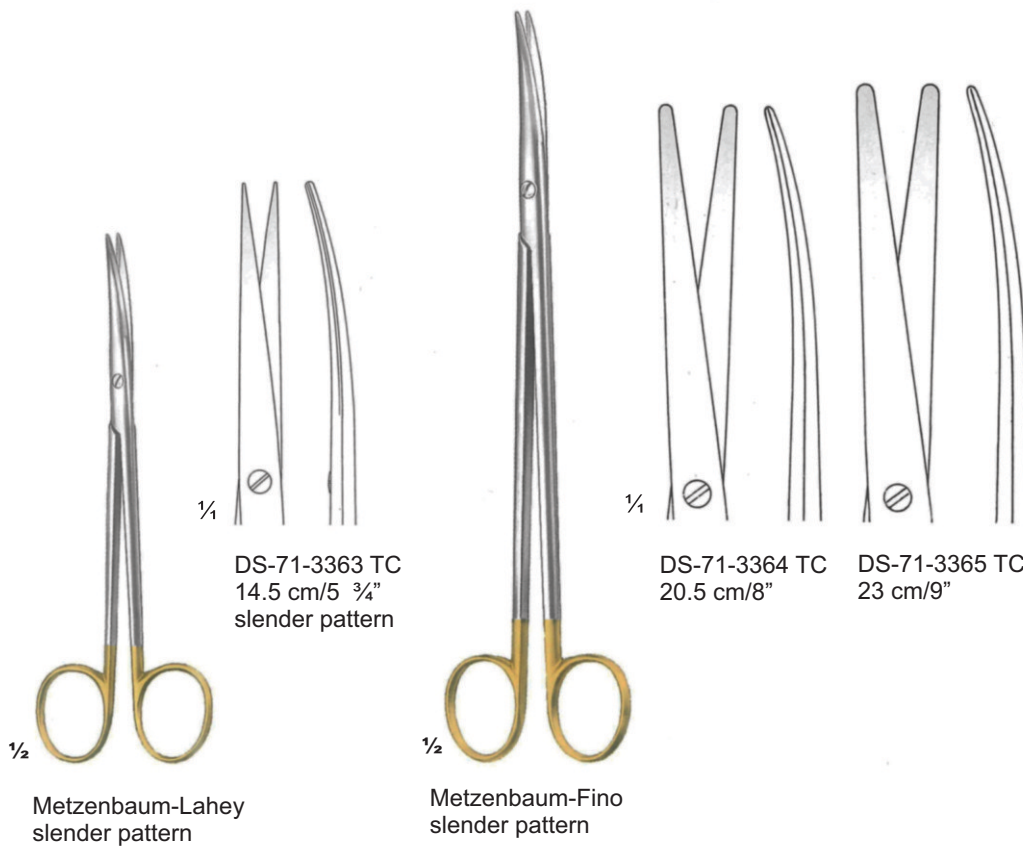
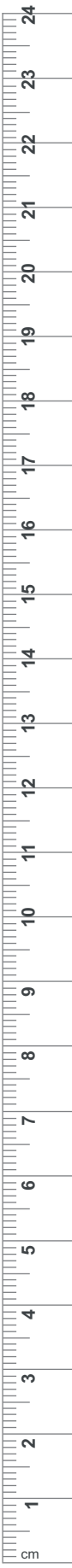

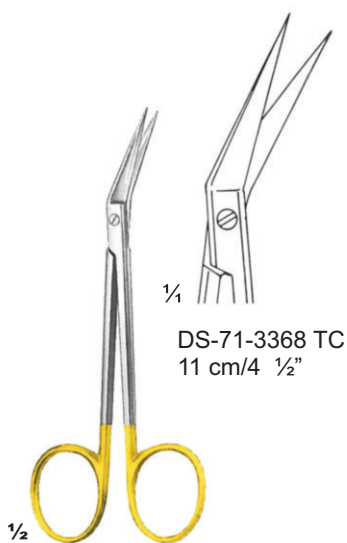
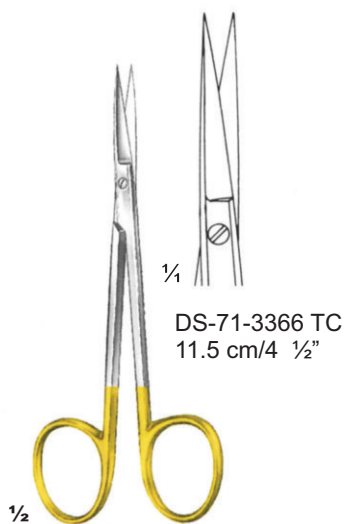

Ragnell

Gum scissors — EN
 Zahnfleschschere — DE
 Tijeras para encías — ES

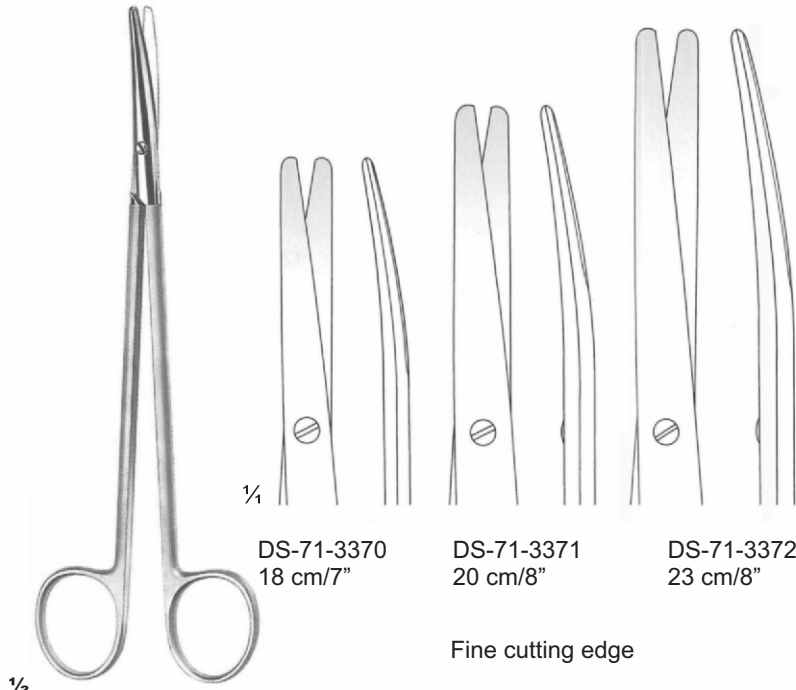

1/2

Metzenbaum

DS-71-3370
18 cm/7"

DS-71-3371
20 cm/8"

DS-71-3372
23 cm/8"

Fine cutting edge

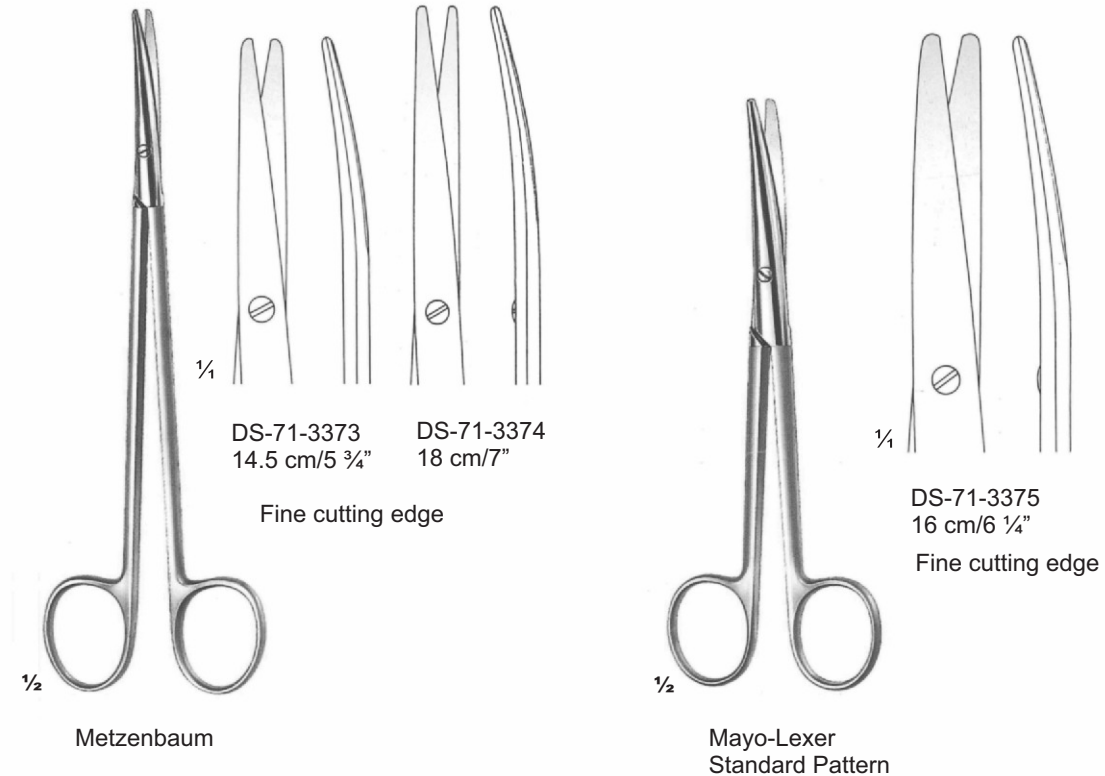

1/2

Metzenbaum

1/2

Mayo-Lexer
Standard Pattern

DS-71-3373
14.5 cm/5 3/4"

DS-71-3374
18 cm/7"

Fine cutting edge

DS-71-3375
16 cm/6 1/4"

Fine cutting edge



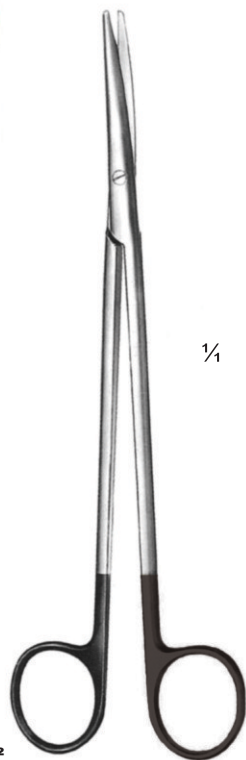

1/4



DS-71-3376 TCS
14.5 cm/5 3/4"



DS-71-3377 TCS
18 cm/7"

For synthetic suture material
One toothed cutting edge

1/2



1/4



DS-71-3378 TCS
14.5 cm/5 3/4"



DS-71-3379 TCS
17 cm/6 3/4"

For synthetic suture material
One toothed cutting edge

1/2

72

EN Micro Scissors

DE Mikroschere

ES Micro tijeras

Page 172 to 173

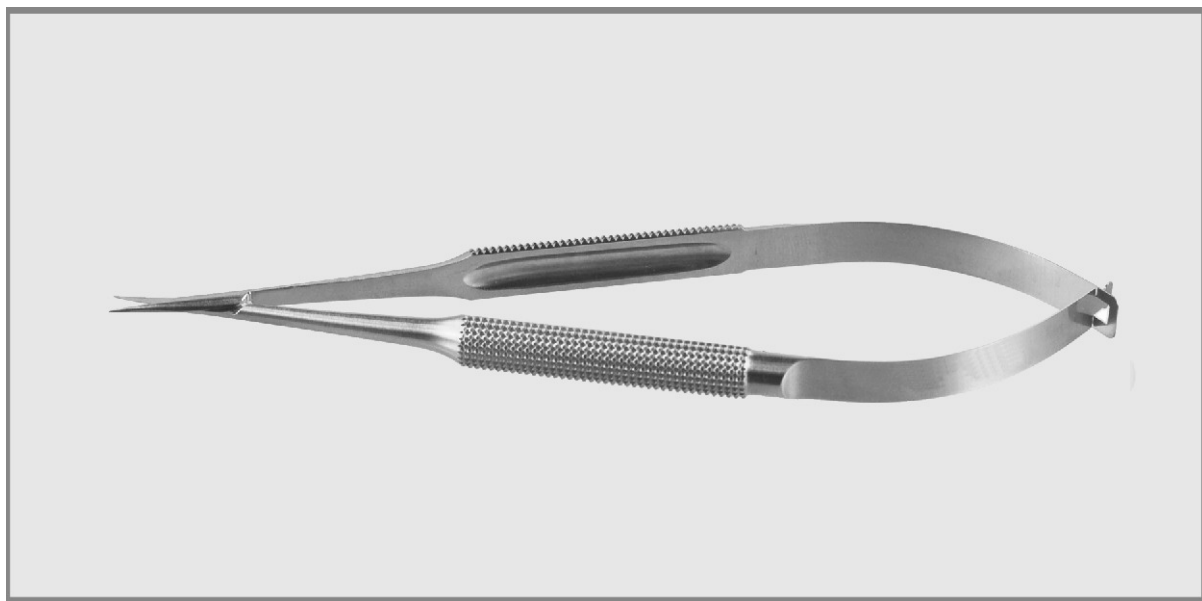

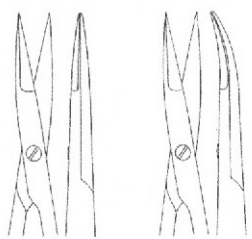

15 cm/6"	DS-72-3401	DS-72-3405
18 cm/7"	DS-72-3402	DS-72-3406
21 cm/8 1/4"	DS-72-3403	DS-72-3407
23 cm/9"	DS-72-3404	DS-72-3408

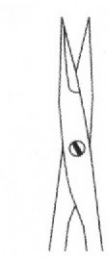

Streamlined

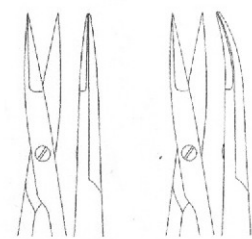

15 cm/6"	DS-72-3409	DS-72-3413
18 cm/7"	DS-72-3410	DS-72-3414
21 cm/8 1/4"	DS-72-3411	DS-72-3415
23 cm/9"	DS-72-3412	DS-72-3416



Streamlined

72

MICRO SCISSORS

Micro Scissors — EN
Mikroscheren — DE
Micro-ciseaux — ES



NOYES
DS-72-3417
13 cm/5"

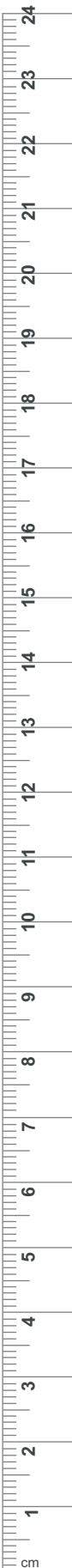

73

- EN** Orthodontics
- DE** Kieferorthopädie
- ES** Ortodoncia

Page 174 to 190

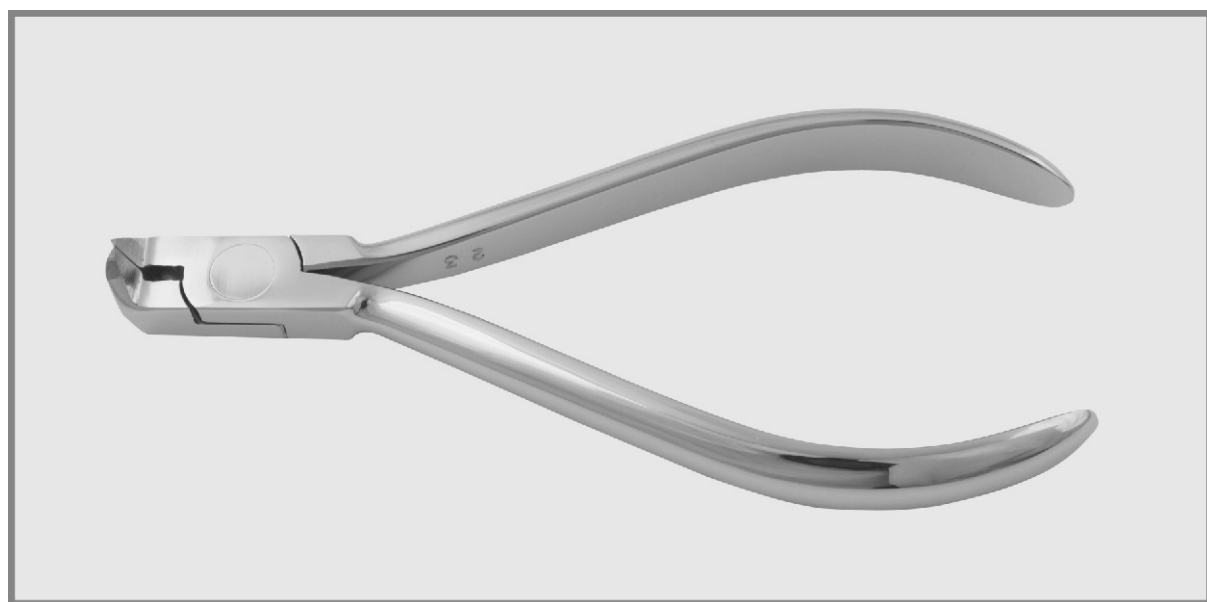



DS-73-3501
14 cm/5 1/2"



LANGENBECK
DS-73-3502
15 cm/6"



DS-73-3503
14 cm/5 1/2"



DS-73-3504
12,5 cm/4 3/4"



DS-73-3505
13 cm/5"



DS-73-3506
14 cm/5 1/2"



Contouring pliers

GOSLEE
 DS-73-3507
 14 cm/5 1/2"



Contouring pliers

GOSLEE
 DS-73-3508
 14 cm/5 1/2"



Contouring pliers

GOSLEE
 DS-73-3509
 14 cm/5 1/2"



serrated

DS-73-3510
 12,5 cm/4 3/4"



round

Flat

DS-73-3511
 15 cm/6"



round
 nose pliers

DS-73-3512
 13 cm/5"

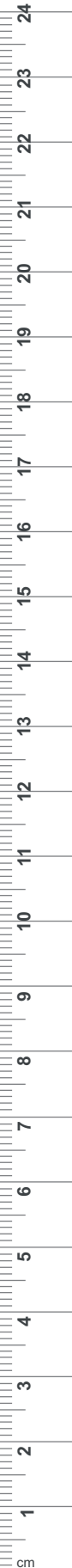



DS-73-3513
13 cm/5"



DS-73-3514
13 cm/5"



LANGENBECK
DS-73-3515
14 cm/5 1/2"



DUMONT
DS-73-3516
11,5 cm/4 1/2"



DUMONT
DS-73-3517
11,5 cm/4 1/2"



DUMONT
DS-73-3518
11,5 cm/4 1/2"

Wire cutter, front action



DS-73-3519
11 cm/4 1/4"



DS-73-3520
11,5 cm/4 1/2"



DS-73-3521
12,5 cm/4 3/4"



DS-73-3522
11,5 cm/4 1/2"



0,7 mmØ
for hard wire up to

DS-73-3523
11,5 cm/4 1/2"

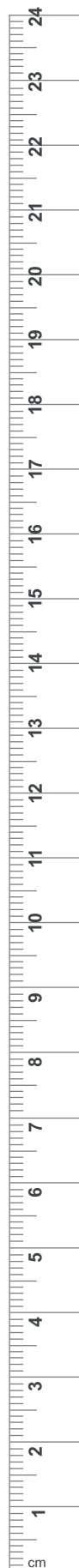



1,0 mm Ø
for hard wire up to



DS-73-3524
15 cm/6"



SCHWARZ
DS-73-3525
13 cm/5"
Modell I

SCHWARZ
DS-73-3528
14,5 cm/5 3/4"



SCHWARZ
DS-73-3526
13 cm/5"
Modell II

FISCHER
DS-73-3529
14 cm/5 1/2"



ANDRESEN
 DS-73-3530
 13,5 cm/5 1/2"



sling forming pliers

McKELLOPS
 DS-73-3531
 17 cm/6 3/4"



McKELLOPS-STADLER
 DS-73-3532
 16 cm/6 1/4"



STADLER
 DS-73-3533
 15 cm/6"



ANGLE
 DS-73-3534
 12,5 cm/5"



ANGLE
 DS-73-3535
 12,5 cm/5"





ADAMS
DS-73-3536
13 cm/5"



YOUNG
DS-73-3537
13 cm/5"



TWEED
DS-73-3538
13,5 cm/5 ½"



TWEED
DS-73-3539
13,5 cm/5 ½"



Contouring pliers

DE LA ROSA
DS-73-3540
12,5 cm/5"



DE LA ROSA
DS-73-3541
12,5 cm/5"

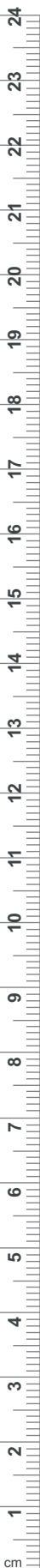

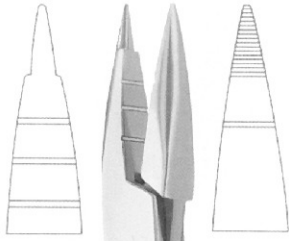

JARABAK
 DS-73-3542
 14 cm/5 1/2"

ovalen Draht bis
 hart 1,5 x 0,75 mm

oval wire up to
 1.5 x 0.75 mm

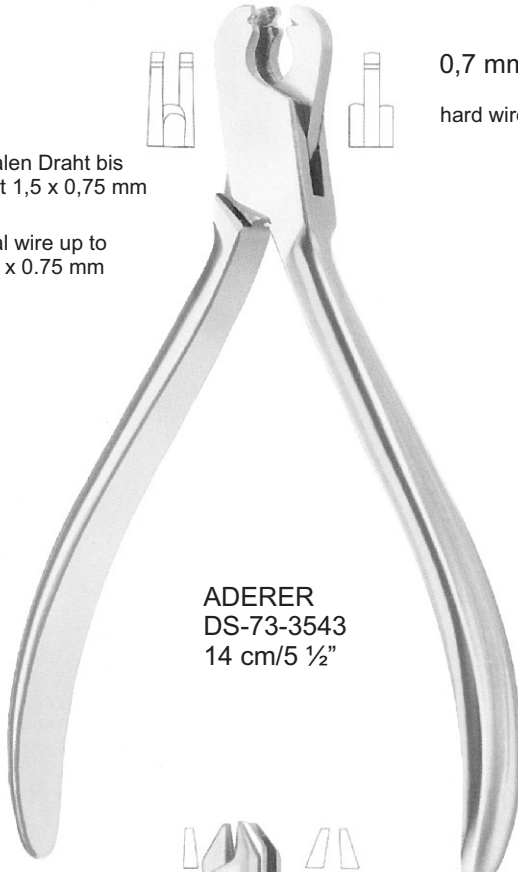

ADERER
 DS-73-3543
 14 cm/5 1/2"

0,7 mm Ø
 hard wire up to

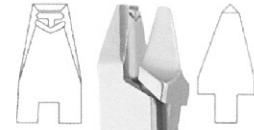

KOEHLER
 DS-73-3544
 12 cm/4 3/4"



DS-73-3545
 14 cm/5 1/2"

0,7 mm Ø
 for hard wire up to

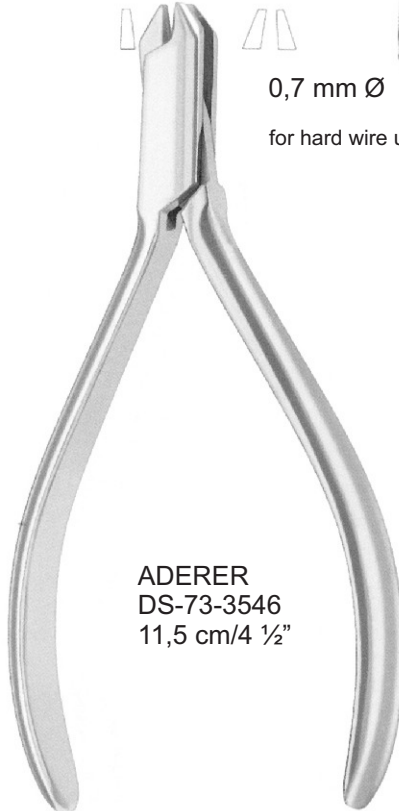

ADERER
 DS-73-3546
 11,5 cm/4 1/2"

0,7 mm Ø
 for hard wire up to

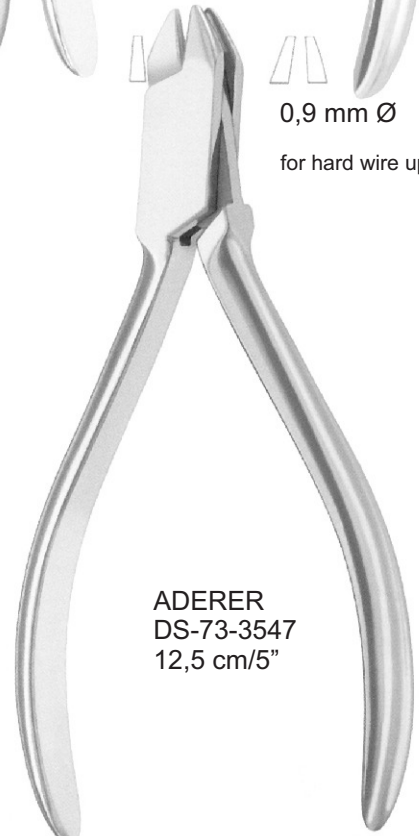

ADERER
 DS-73-3547
 12,5 cm/5"

0,9 mm Ø
 for hard wire up to

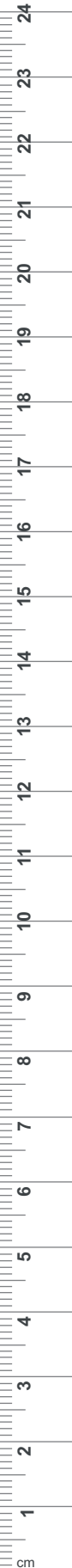



Bending Pliers

ANGLE
DS-73-3548
13 cm/5"



ANGLE
DS-73-3549
13 cm/5"



WALDSACHS
DS-73-3550
15,5 cm/6"



Universal
DS-73-3551
15,5 cm/6 ¼"



DS-73-3552
15,5 cm/6 ¼"



FURRER
DS-73-3553
15 cm/6"

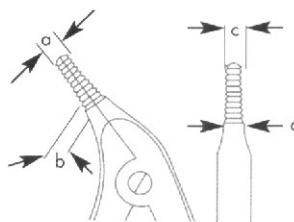

a	b	c	d
3,3	4	2,3	3,0
4,4	5	3,4	3,8

Telescope crown pliers

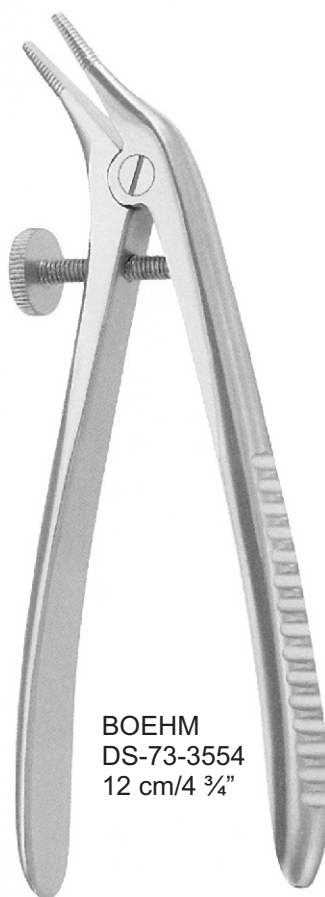

BOEHM
 DS-73-3554
 12 cm/4 3/4"



BOEHM
 DS-73-3555
 15 cm/4"

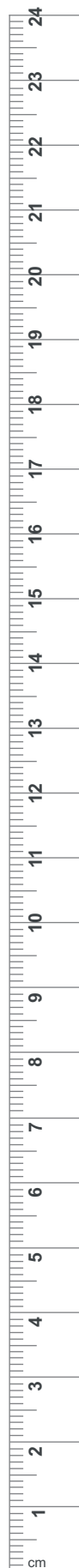



OLIVER
JONES
DS-73-3556
15 cm/6"



OLIVER
DS-73-3557
15 cm/6"



OLIVER
DS-73-3558
15 cm/6"

Step loop bending pliers



ADERER
DS-73-3559
13,5 cm/5 1/4"



NANCE
DS-73-3560
12,5 cm/5"

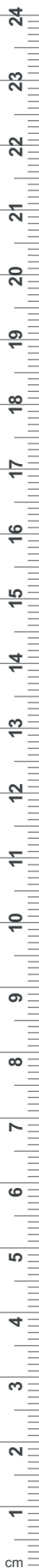



0,7 mm Ø

for hard wire up to

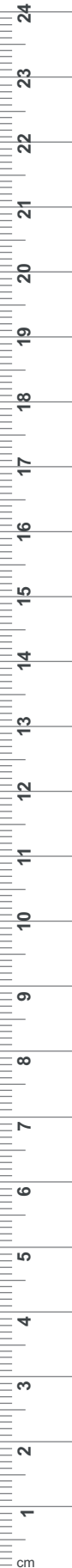



TRYFUS
DS-73-3567
16 cm/6 1/4"

Crown stretching pliers



PEESO
DS-73-3568
12 cm/6 1/4"

smooth



PEESO
DS-73-3569
13,5 cm/5 1/4"

serrated



PEESO
DS-73-3570
14 cm/5 1/2"

straight



HOW
DS-73-3571
14 cm/5 1/2"

curved



HOW
DS-73-3572
14 cm/5 1/2"



DS-73-3573
 18 cm/7"



DS-73-3574
 14,5 cm/5 3/4"

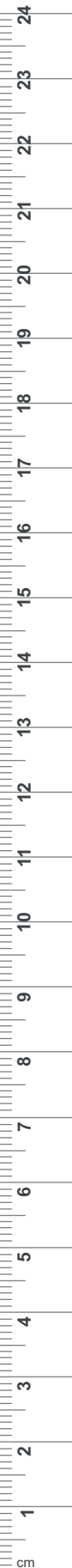



FREVERT
 DS-73-3575
 12 cm/4 3/4"



TRIPLEX
 DS-73-3576
 14 cm/5 1/2"



REYNOLD
 DS-73-3577
 12 cm/4 3/4"



GORDON
 DS-73-3578
 13,5 cm/5 1/4"

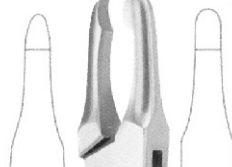

JOHNSON
 DS-73-3579
 13 cm/5"

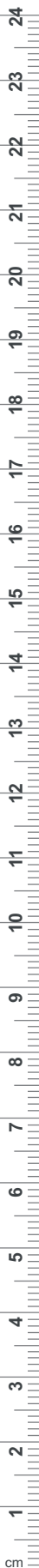

Clamping tweezer / bracket holder



DS-73-3580 DS-73-3581 DS-73-3582 DS-73-3583 DS-73-3584 DS-73-3585 DS-73-3586 DS-73-3587 Bracket P. Gauge DS-73-3588 Band Remover DS-73-3589 Band Remover

Bracket positioning gauge



DS-73-3590





DS-73-3591
12.5 cm/5"



DS-73-3592
12.5 cm/5"



DS-73-3593
12.5 cm/5"



DS-73-3594
12.5 cm/5"



DS-73-3595
12.5 cm/5"



DS-73-3596
12.5 cm/5"



DS-73-3597
12.5 cm/5"



DS-73-3598
12.5 cm/5"



DS-73-3599
12.5 cm/5"



DS-73-3600
12.5 cm/5"



DS-73-3601
12.5 cm/5"



DS-73-3602
12.5 cm/5"

74

- EN** Bone Rongeurs
- DE** Knochen Rongeur
- ES** Rongeurs de hueso

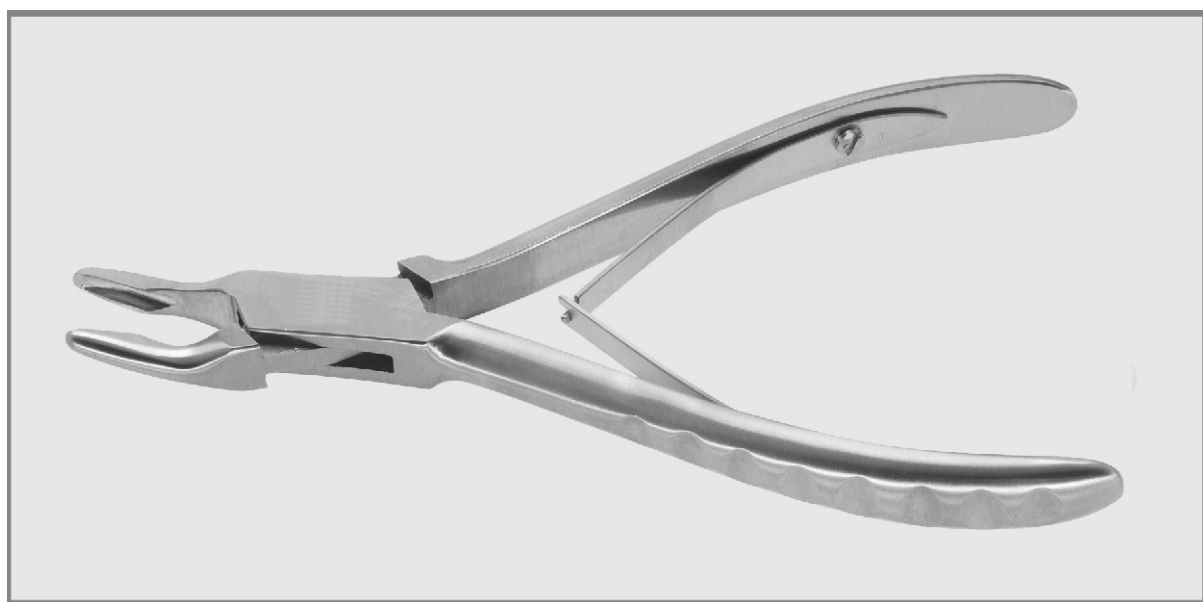

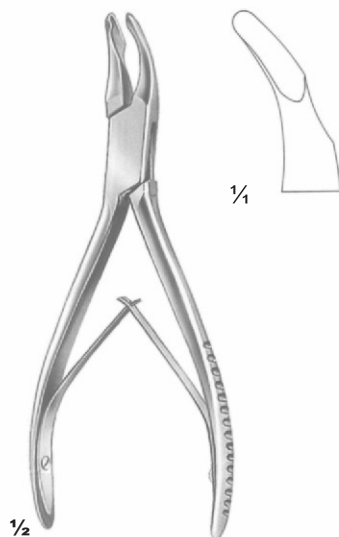

Cleveland
 DS-74-3701
 15 cm

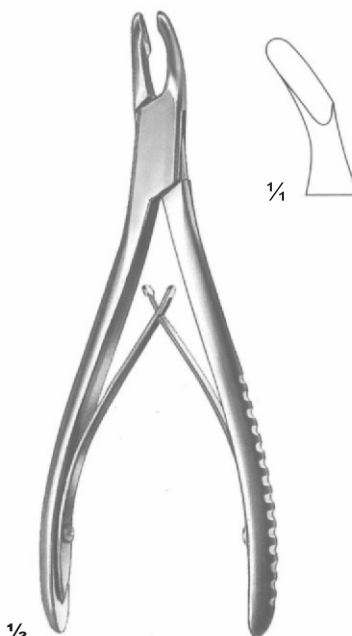

Cleveland
 DS-74-3702
 15 cm

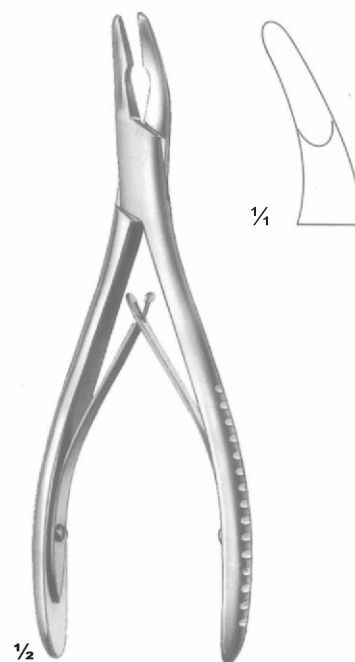

Hartmann
 DS-74-3703
 18 cm

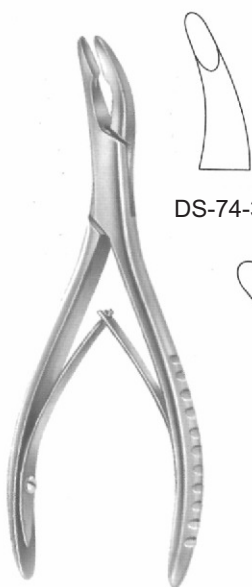

LUER
 15 cm



DS-74-3704



DS-74-3705



DS-74-3706



BLUMENTHAL
 15 cm



DS-74-3707
 16 cm/6 1/4



DS-74-3708
 15.5 cm/6 1/8



DS-74-3709
 15.5 cm/6 1/8

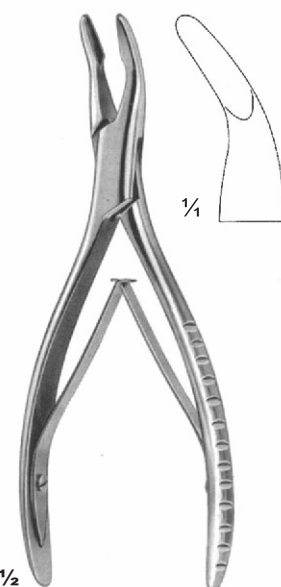

MEAD
 DS-74-3710
 16.5 cm/6 1/2"

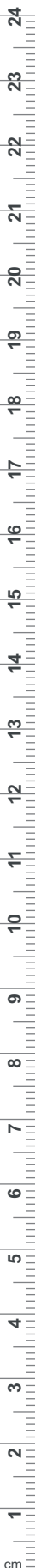

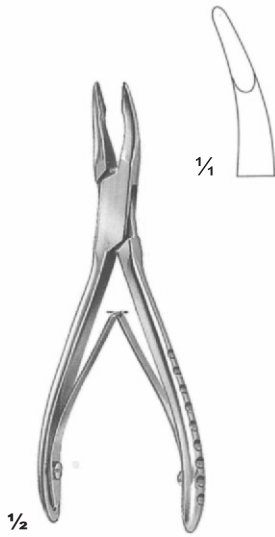

Friedmann
 DS-74-3711
 14 cm

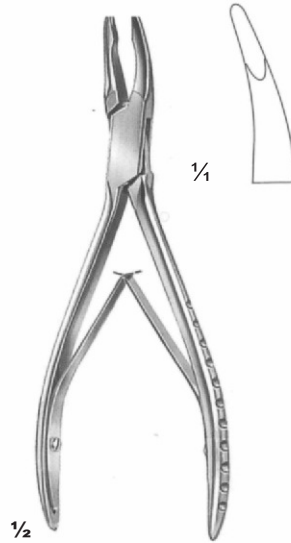

Friedmann
 DS-74-3712
 14 cm

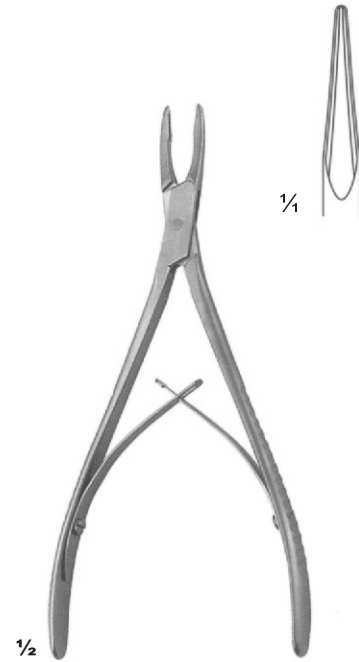

Friedmann-Micro
 DS-74-3713
 15 cm/6"
 straight

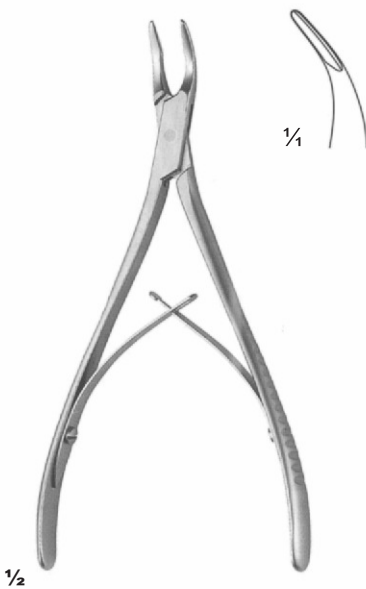

Friedmann-Micro
 DS-74-3714
 15 cm/6"
 30°

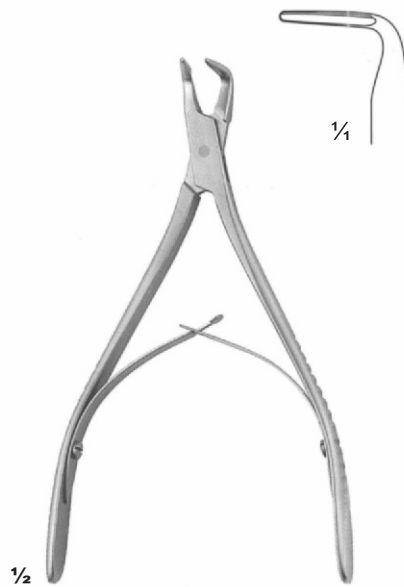

Friedmann-Micro
 DS-74-3715
 14.5 cm/5 3/4"
 90°

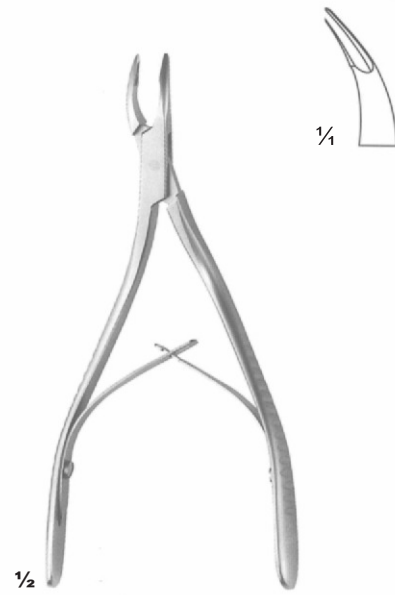

Friedmann-Micro
 DS-74-3716
 14.5 cm/5 3/4"
 S shape
 30°

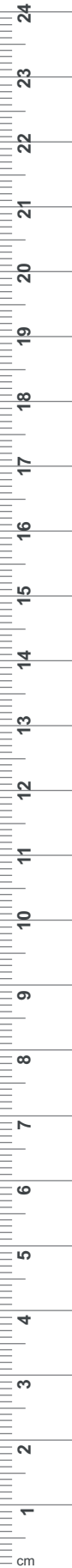



1/4

DS-74-3717



DS-74-3718

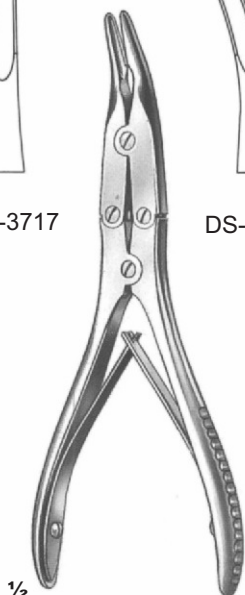

1/2

Bohler
15.5 cm/6"



1/4

Beyer
DS-74-3719
18 cm/7"



1/2



1/4

Mayfield
DS-74-3720
18 cm/7"



1/2



1/4

Zaufal-Jansen
DS-74-3721
18 cm/7"

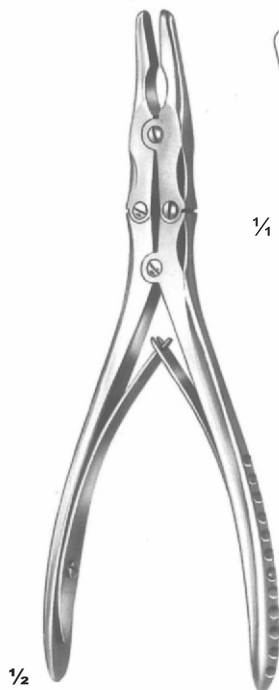

1/2



1/4

Ruskin
DS-74-3722
19 cm/7 1/2"



1/2

75

EN Forceps

DE Zange

ES Fórceps

Page 194 to 201

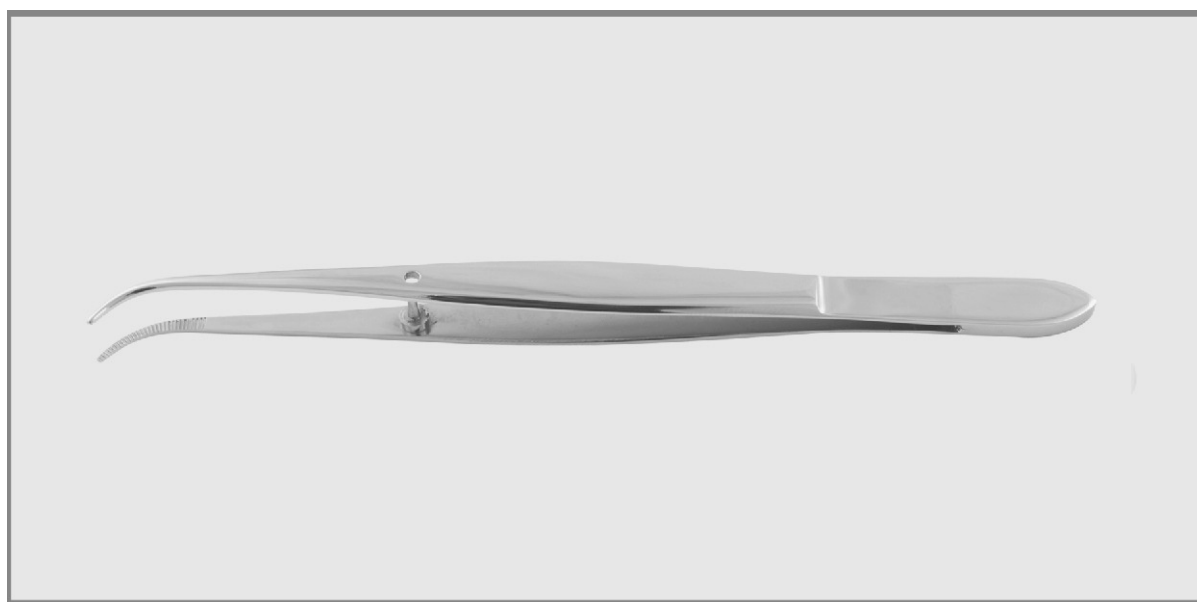



standard pattern

1/2

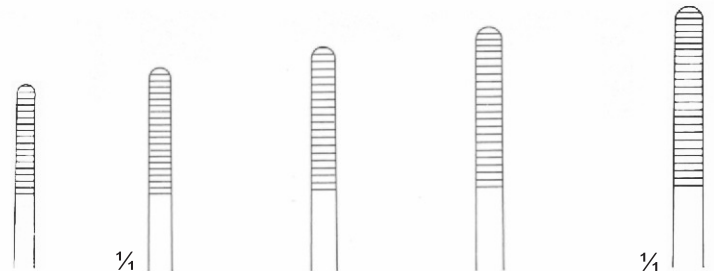

DS-75-3801 13 cm/5 1/8" DS-75-3802 14.5 cm/5 3/4" DS-75-3803 16 cm/5 1/4" DS-75-3804 18 cm/7" DS-75-3805 20 cm/7 7/8"



slender pattern



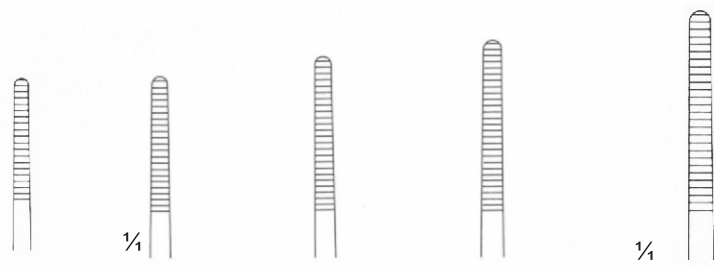

1/2

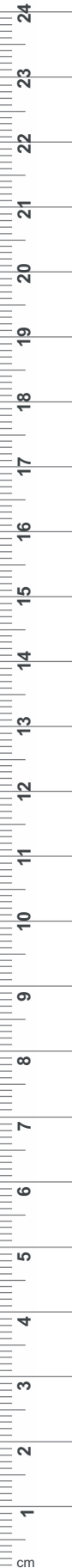
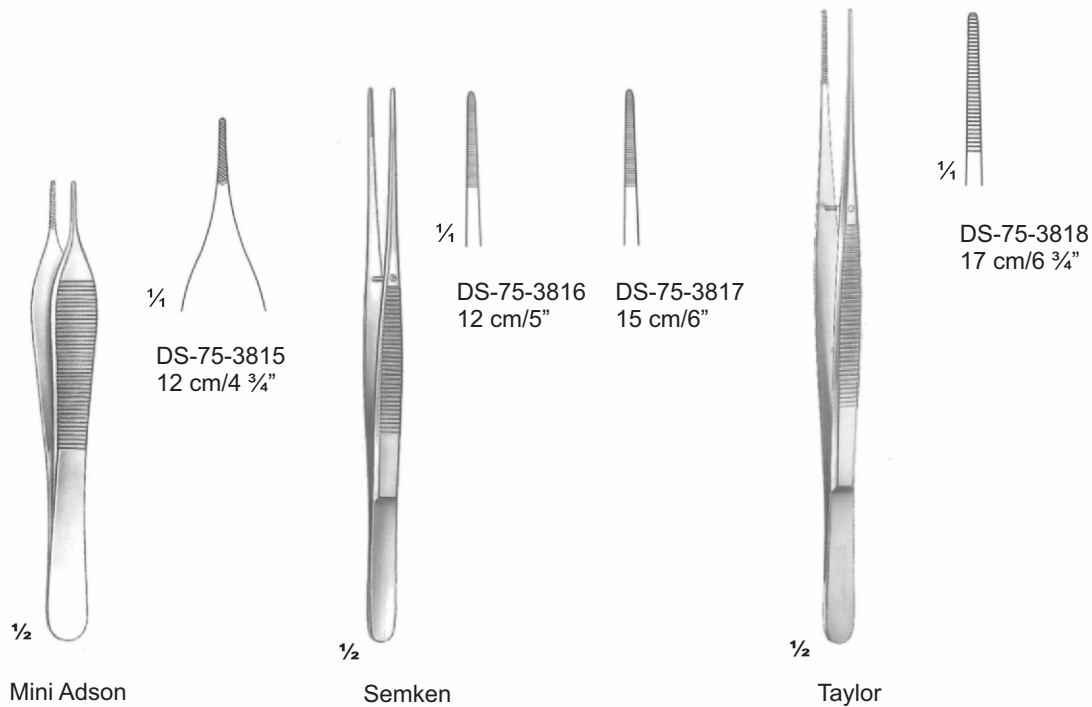
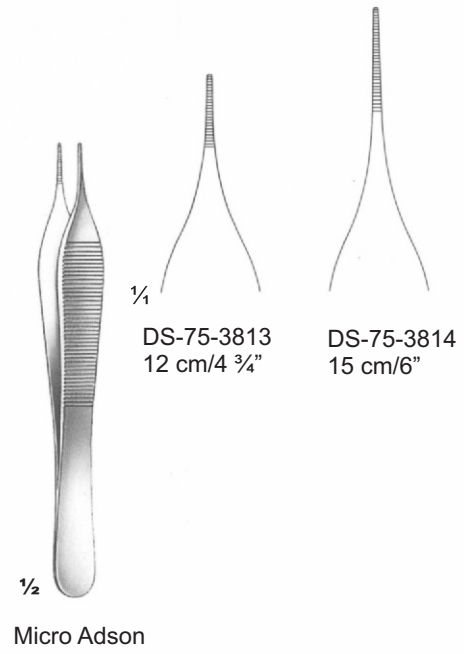
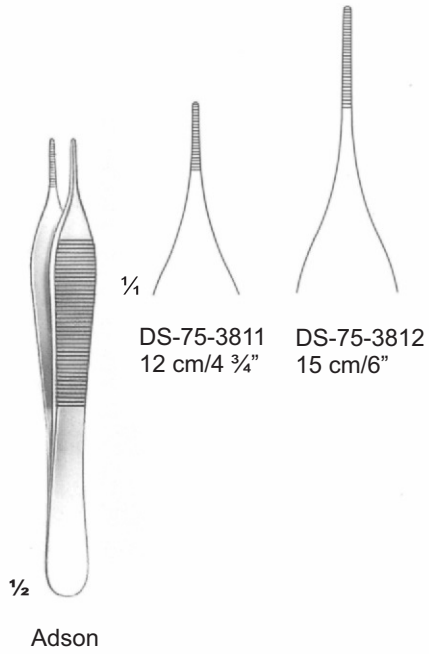

DS-75-3806 13 cm/5 1/8" DS-75-3807 14.5 cm/5 3/4" DS-75-3808 16 cm/5 1/4" DS-75-3809 18 cm/7" DS-75-3810 20 cm/7 7/8"









				
	1/4			1/4
DS-75-3819 13 cm/5 1/8" 1x2	DS-75-3820 14.5 cm/5 3/4" 1x2	DS-75-3821 16 cm/6 1/4" 1x2	DS-75-3822 18 cm/7" 1x2	DS-75-3823 20.5 cm/8 1/8" 1x2



Standard Pattern



				
1/4	1/4			1/4
DS-75-3824 13 cm/5 1/8" 1x2	DS-75-3825 14.5 cm/5 3/4" 1x2	DS-75-3826 16 cm/6 1/4" 1x2	DS-75-3827 18 cm/7" 1x2	DS-75-3828 20.5 cm/8 1/8" 1x2



Slender Pattern



	
1/4	1/4
DS-75-3829 12 cm/4 3/4" 1x2	DS-75-3830 15 cm/5 7/8" 1x2

Adson



	
1/4	1/4
DS-75-3831 12 cm/4 3/4" 1x2	DS-75-3832 12 cm/4 3/4" 1x2

Mini Adson

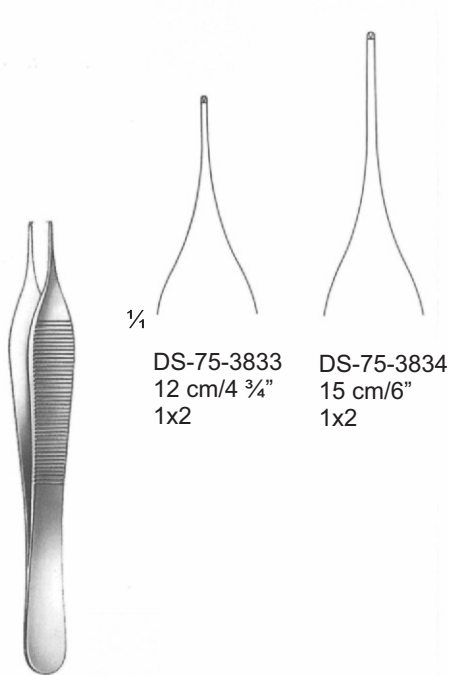

DS-75-3833
 12 cm/4 3/4"
 1x2

DS-75-3834
 15 cm/6"
 1x2

Mikro Adson

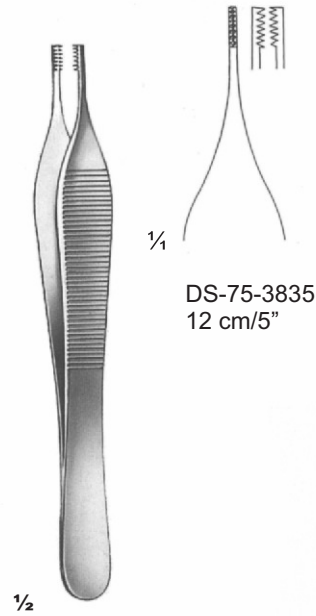

DS-75-3835
 12 cm/5"

1/2

Adson-Brown

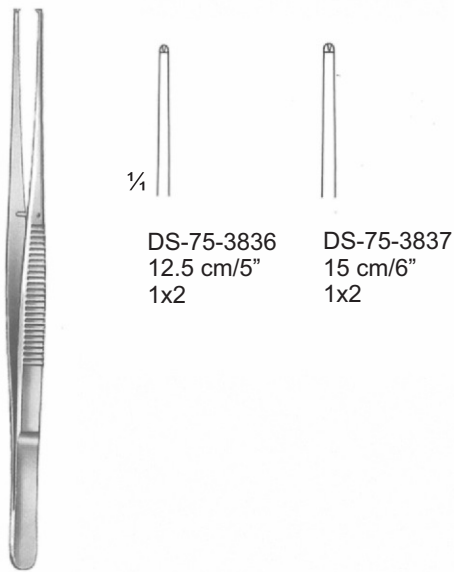

DS-75-3836
 12.5 cm/5"
 1x2

DS-75-3837
 15 cm/6"
 1x2

Semken

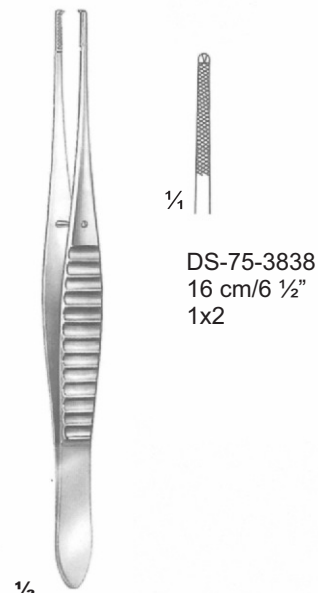

DS-75-3838
 16 cm/6 1/2"
 1x2

1/2

Gillies

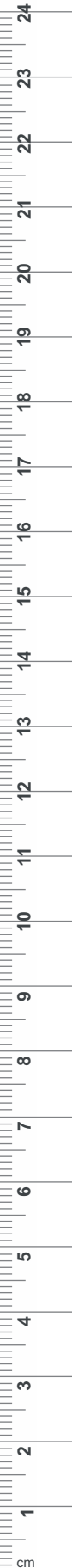



DS-75-3838A
15 cm/6"

suited to hold silver pins, nerve-broaches and for introducing medicines



1/2

Suture and membrane forceps

D = 1,6 mm



1/4

DS-75-3839
16 cm/6 1/4"

D = 2,2 mm



1/4

DS-75-3840
16 cm/6 1/4"



1/2



1/4

DS-75-3841
16 cm/6 1/4"



London-College
15 cm/6"



1/4

DS-75-3842
No. 1

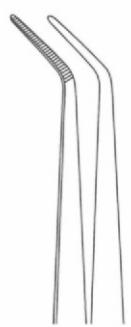

DS-75-3843
No. 3



DS-75-3844
No. 5



1/2

London-College
with lock
15 cm/6"



1/4

DS-75-3845
No. 1

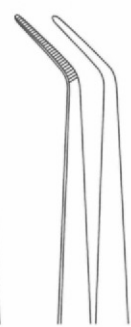

DS-75-3846
No. 3



DS-75-3847
No. 5



$\frac{2}{3}$
 Perry
 DS-75-3848
 13 cm/5"



$\frac{1}{4}$
 serrated



$\frac{2}{3}$
 Perry
 DS-75-3849
 13 cm/5"



$\frac{1}{4}$
 smooth



$\frac{1}{2}$
 DS-75-3850
 14.5 cm/5 $\frac{3}{4}$ "
 Frigz
 Grasping and
 sterilizing forceps



$\frac{1}{4}$



$\frac{1}{4}$
 DS-75-3851
 20 cm/8"
 Seizing and
 Sterilizing Forceps





DeBakey
12 cm/5"

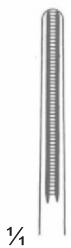

DS-75-3852
2,7 mm



DS-75-3853
1,5 mm



DS-75-3854
2,0 mm



DS-75-3855
2,0 mm



DS-75-3856
3,5 mm



Crane-Kaplan
Pocket marking forceps
15 cm/6"

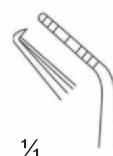

DS-75-3857
No. 1

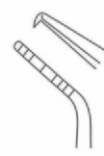

DS-75-3858
No. 2



Meriam
16 cm/6 1/4"

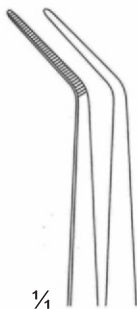

DS-75-3859
No. 1



DS-75-3860
No. 3



DS-75-3861
No. 5



Flagg
16 cm/6 1/4"



DS-75-3862
No. 1



DS-75-3863
No. 2



DS-75-3864
No. 3



DS-75-3865
No. 4

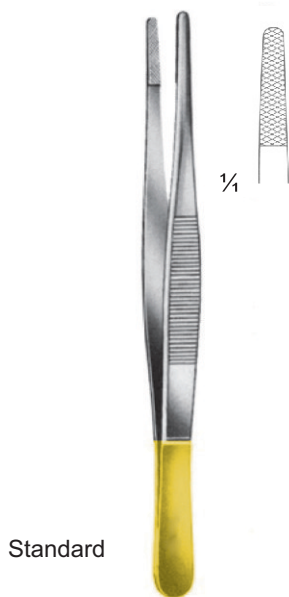

Standard

DS-75-3866 TC
 14.5 cm/5 3/4"

DS-75-3867 TC
 18 cm/ 7"



delicate

DS-75-3868 TC
 14.5 cm/5 3/4"

DS-75-3869 TC
 18 cm/7"



1/2

Adson

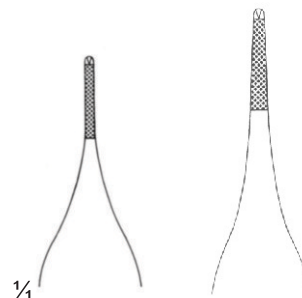

1/4

DS-75-3870 TC
 12 cm/4 3/4
 1x2

DS-75-3871 TC
 15 cm/6"
 1x2

mini profile

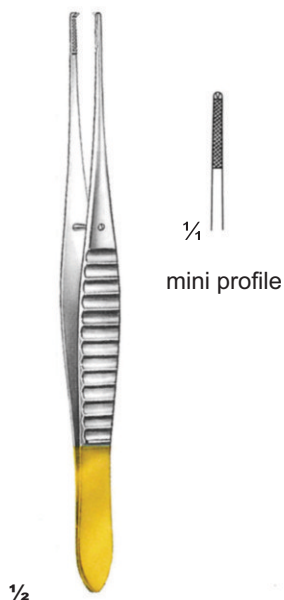

1/2

Gillies
 DS-75-3872 TC
 15.5 cm/6"
 1x2

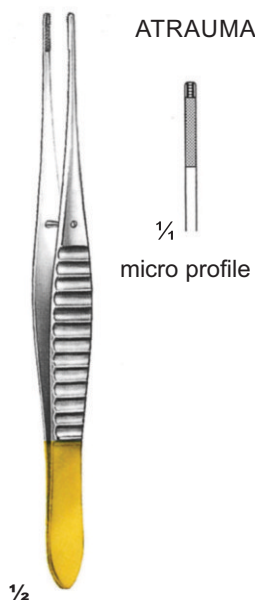

1/2

DeBakey
 DS-75-3873 TC
 16 cm/6 1/4"

ATRAUMA

micro profile

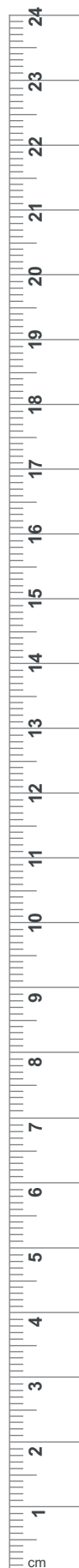

76

- EN** Scalpel Handles
- DE** Skalpellgriffe
- ES** Manches de bistouris

Page 202 to 203

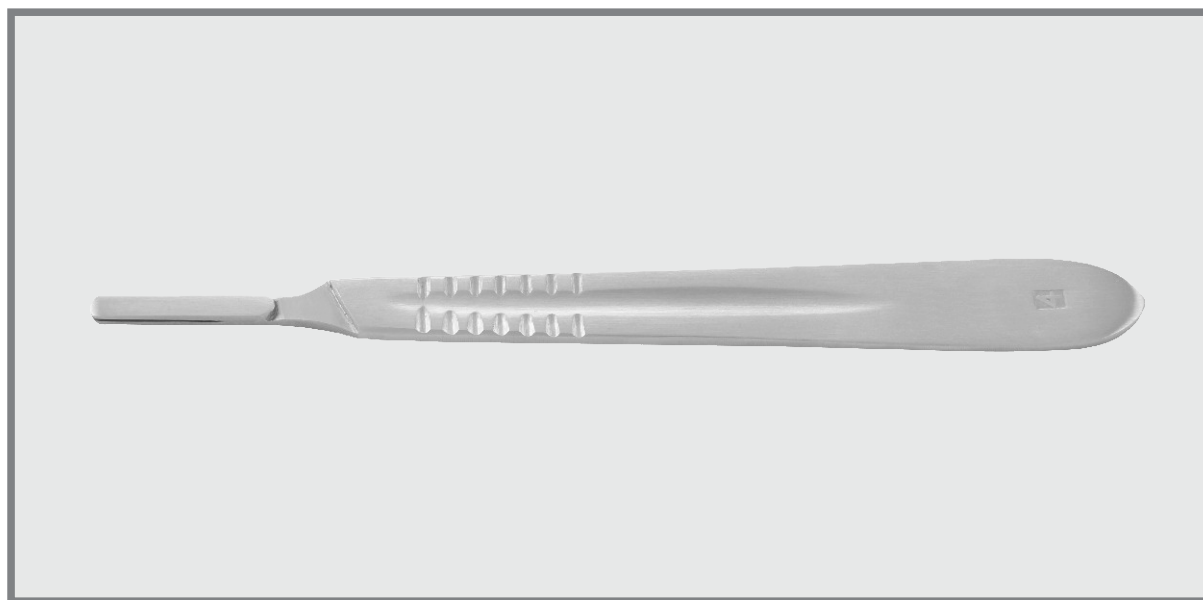

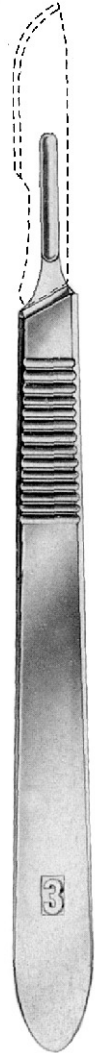

Standard
DS-76-3901 # 3

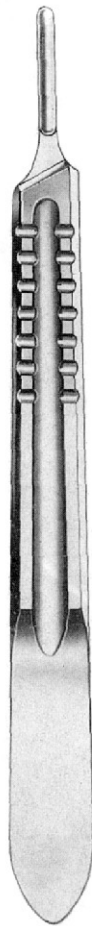

DS-76-3902 # 3



DS-76-3903 # 3
with scale

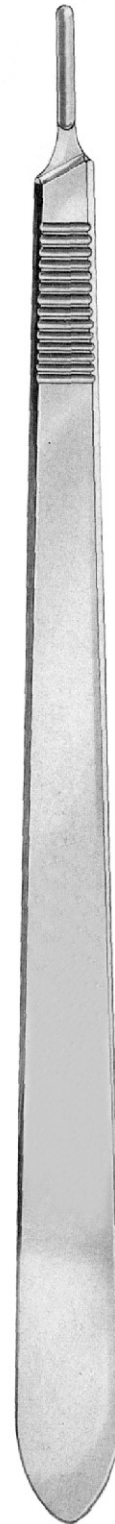

DS-76-3904-3L # 3L
DS-76-3905-3XL # 3XL

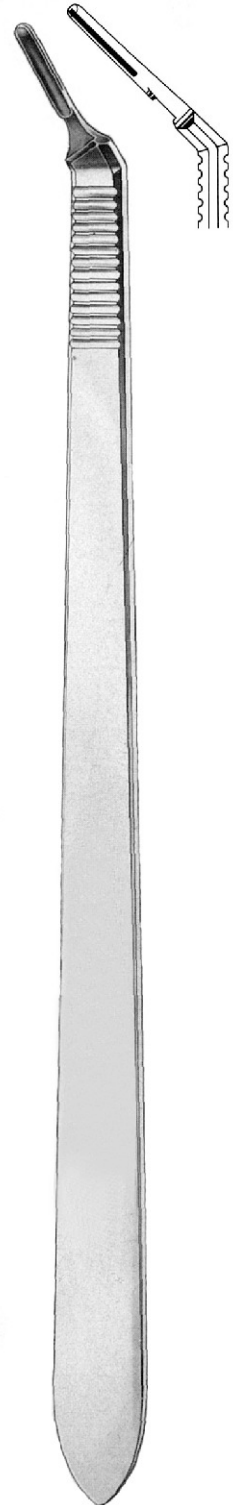

DS-76-3906-3L # 3L
DS-76-3907-3XL # 3XL
angled

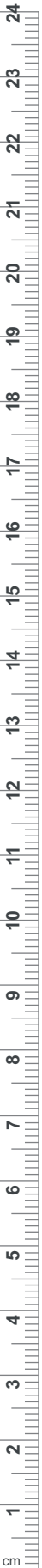

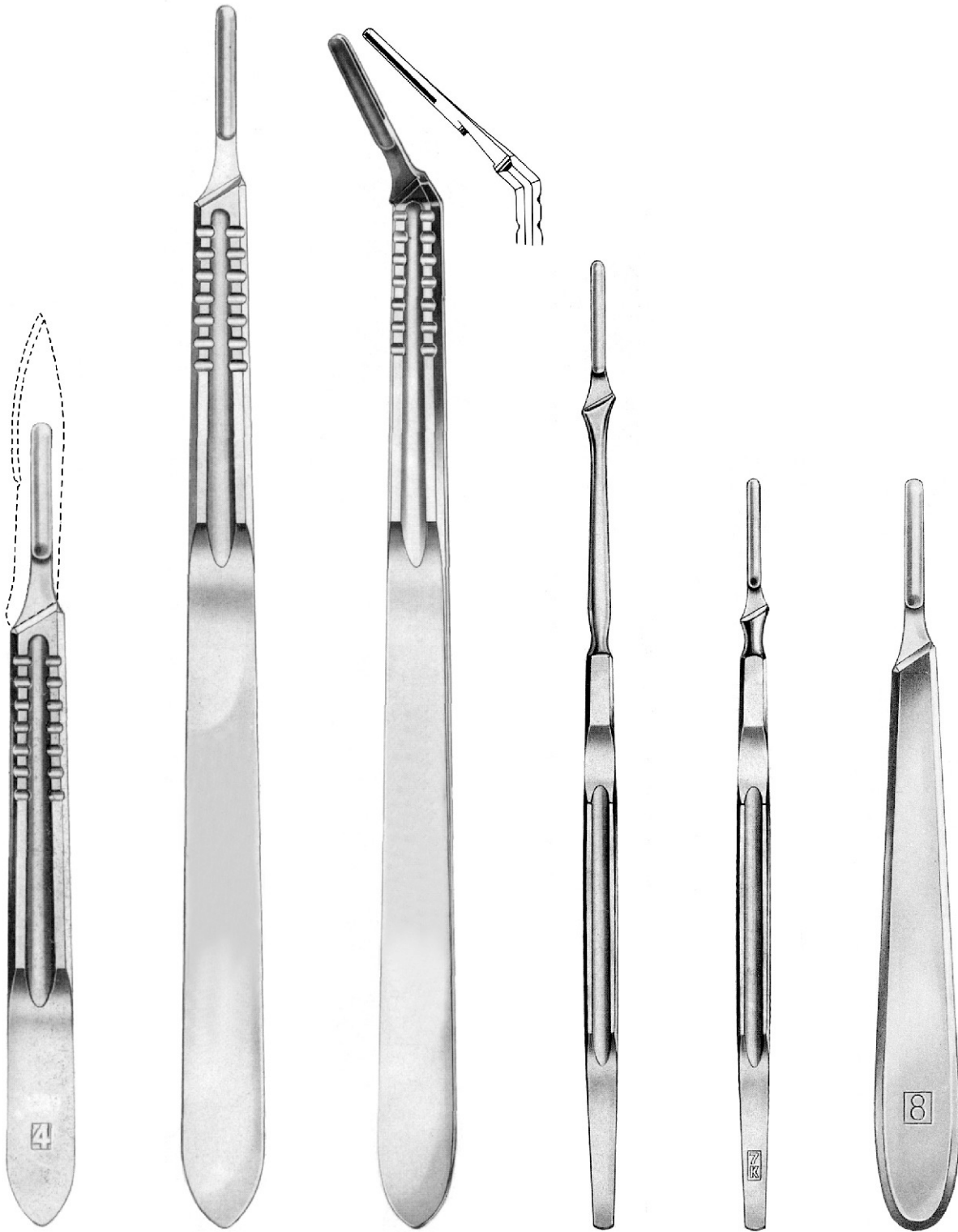

Standard
 DS-76-3908
 # 4

DS-76-3909-4L # 4L
 DS-76-3910-4XL # 4XL

DS-76-3911-4L # 4L
 DS-76-3912-4XL # 4XL
 angled

DS-76-3913
 # 7

DS-76-3914
 # 7K

Collin
 DS-76-3915
 Fig. 8

77

EN Mallets

DE Schlägel

ES Mazos

Page 204 to 206

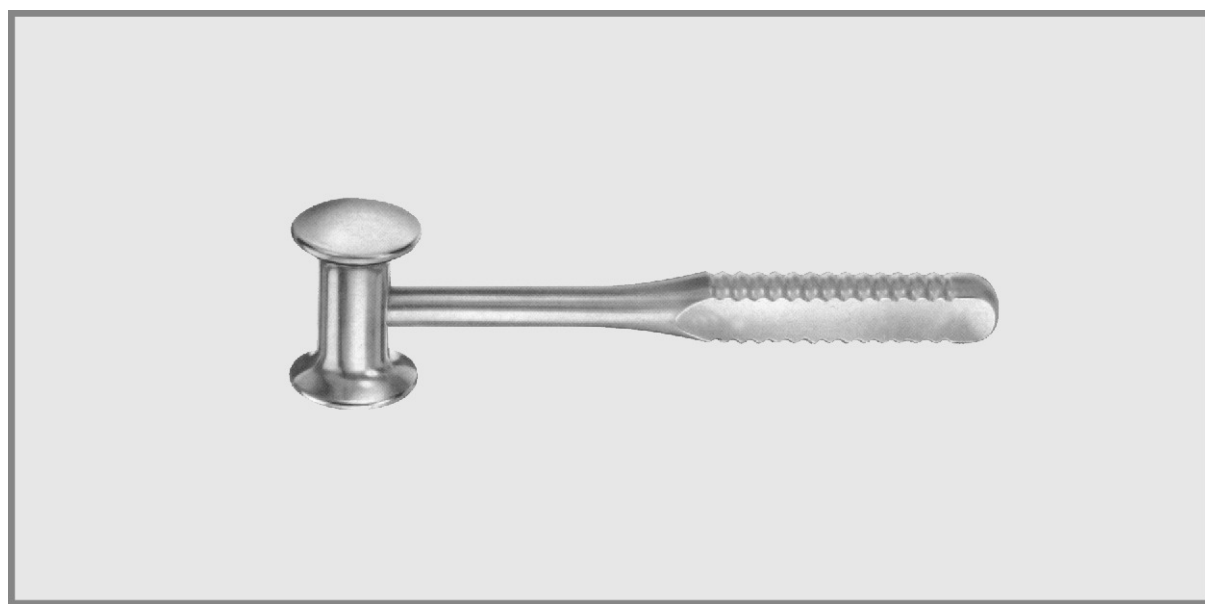



BERGMANN
 DS-77-3951
 24 cm/9 1/2"
 300 grams



WILLIGER
 24 cm/9 1/2"
 lead filled

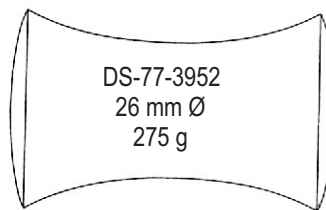

DS-77-3952
 26 mm Ø
 275 g

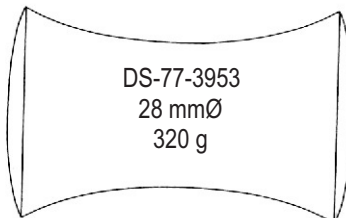

DS-77-3953
 28 mm Ø
 320 g

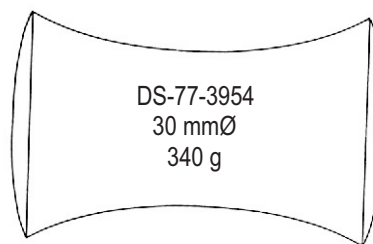

DS-77-3954
 30 mm Ø
 340 g

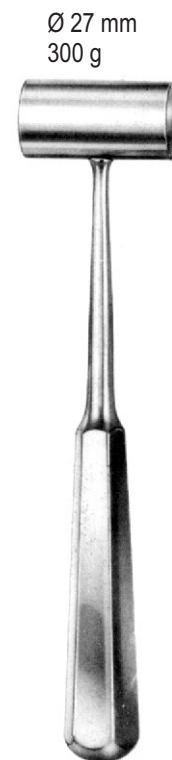

Ø 27 mm
 300 g

PARTSCH
 DS-77-3955
 18 cm/7 1/8"
 with hollow handle



DOYEN
 21 cm/8 1/4"

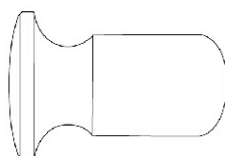

DS-77-3956
 25 mm Ø
 120 g (4 1/4 oz.)
 19.5 cm/7 3/4"

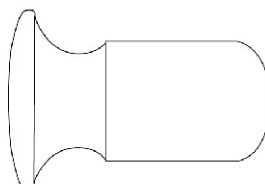

DS-77-3957
 30 mm Ø
 180 g (6 1/2 oz.)
 19.5 cm/7 3/4"

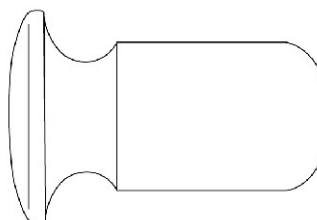

DS-77-3958
 35 mm Ø
 260 g (9 oz.)
 21 cm/8 1/4"



with interchangeable
 plastic disks

MEAD
 DS-77-3959 19 cm/7 1/2"
 DS-77-3960 pair of spare disks





HAJEK
 DS-77-3961
 20 cm/7⁷/₈"
 200 g
 Ø 27 mm



KIRK
 DS-77-3962
 21 cm/8 1/4"
 650 g
 Ø 38 mm

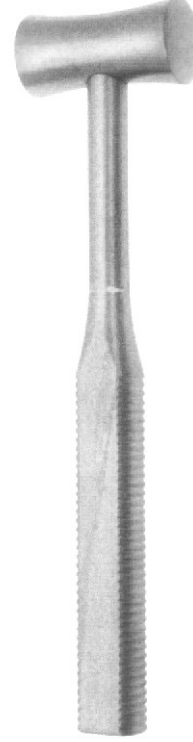

BERGMANN
 DS-77-3963
 24.5 cm/9 5/8"
 400 g
 Ø 30 mm

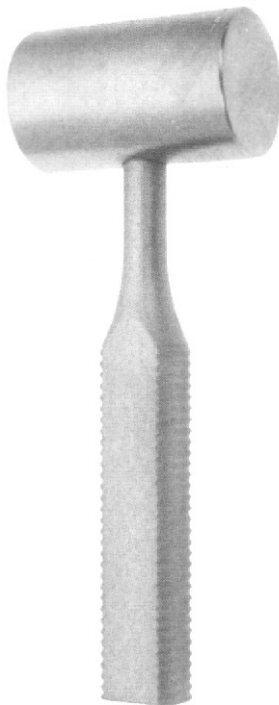

HEATH
 DS-77-3964
 18.5 cm/7 1/4"
 700 g
 Ø 40 mm



with interchangeable
 disks
 DS-77-3966

DS-77-3965
 18.5 cm/7 1/4"
 240 g
 Ø 25 mm

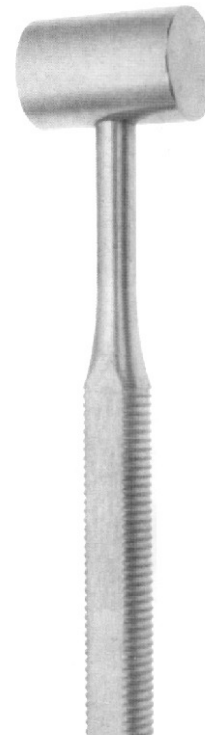

OMBREDANNE
 DS-77-3967
 24 cm/9 1/2"
 700 g
 Ø 40 mm

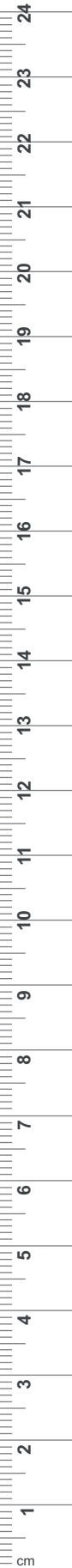



DS-77-3968
26.5 cm/10 3/8"
Ø 50 mm
1300 g

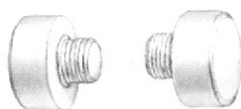

DS-77-3969
spare facings (pair)

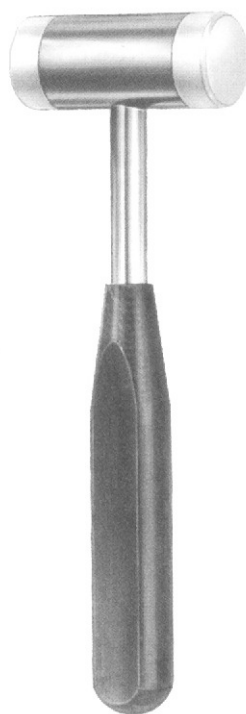

DS-77-3970
19 cm/7 1/2"
Ø 25 mm
300 g



HERBERT
DS-77-3971
19 cm/7 1/2"
Ø 25 mm
215 g

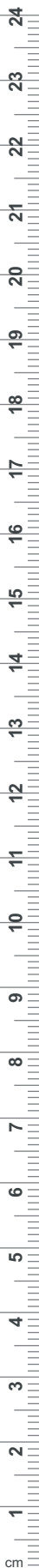

78

EN Cassettes

DE Kassetten

ES Cassettes

Page 207 to 210





Elongated Holes

Dimension(mm)

DS-78-4001	05-Instruments	78 x 182 x 32
DS-78-4002	10-Instruments	142 x 182 x 32
DS-78-4003	20-Instruments	270 x 182 x 32



Round Bottom with Strip Lock

Dimension(mm)

DS-78-4004	05-Instruments	90 x 182 x 25
DS-78-4005	10-Instruments	145 x 182 x 25
DS-78-4006	20-Instruments	270 x 182 x 25



Square

Dimension(mm)

DS-78-4007	05-Instruments	180 x 70 x 22
DS-78-4008	10-Instruments	180 x 130 x 22
DS-78-4009	20-Instruments	260 x 180 x 22

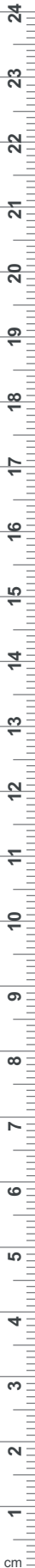

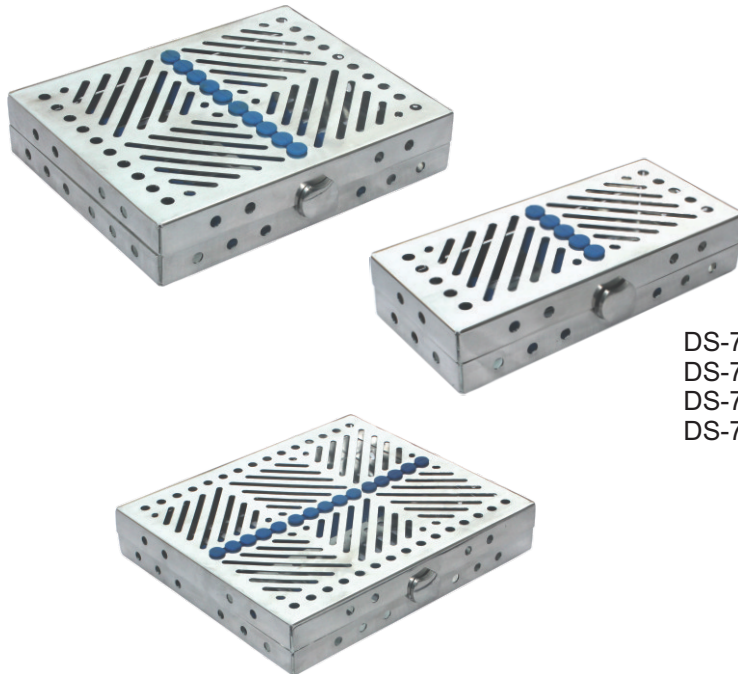

Elongated Holes

Model	Instruments	Dimension(mm)
DS-78-4010	05-Instruments	180 x 80 x 35
DS-78-4011	10-Instruments	180 x 145 x 35
DS-78-4012	15-Instruments	210 x 180 x 35
DS-78-4013	20-Instruments	280 x 180 x 35

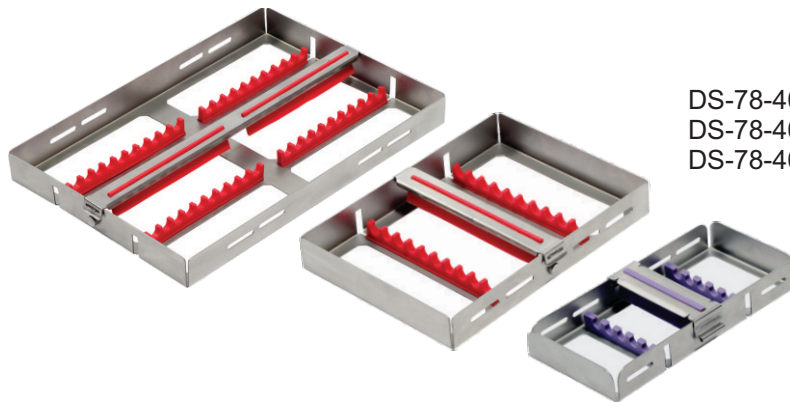

Strip Lock "H" Type

Model	Instruments	Dimension(mm)
DS-78-4014	05-Instruments	180 x 80 x 25
DS-78-4015	10-Instruments	180 x 130 x 25
DS-78-4016	20-Instruments	260 x 180 x 25

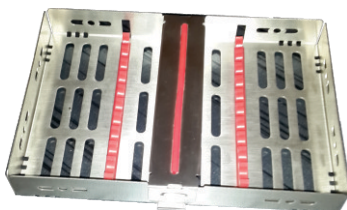

Strip Lock

Model	Instruments	Dimension(mm)
DS-78-4017	05-Instruments	180 x 80 x 25
DS-78-4018	10-Instruments	180 x 130 x 25
DS-78-4019	20-Instruments	260 x 180 x 25

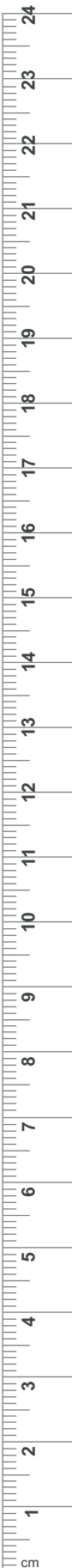



	<u>Dimension(mm)</u>
DS-78-4020	405 x 255 x 50
DS-78-4021	405 x 255 x 70
DS-78-4022	405 x 255 x 100



	<u>Dimension(mm)</u>
DS-78-4023	255 x 245 x 50
DS-78-4024	255 x 245 x 70
DS-78-4025	255 x 245 x 100



	<u>Dimension(mm)</u>
DS-78-4026	255 x 120 x 50
DS-78-4027	255 x 120 x 70

LIDs (optional)

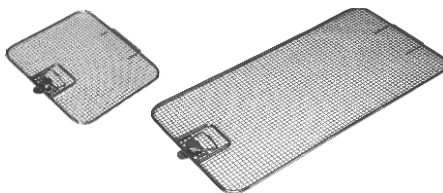

	<u>Dimension(mm)</u>
DS-78-4028	255 x 120
DS-78-4029	255 x 245
DS-78-4030	250 x 240
DS-78-4031	540 x 255
DS-78-4032	485 x 255
DS-78-4033	405 x 255
DS-78-4034	480 x 370
DS-78-4035	480 x 250

Endoscopic Baskets

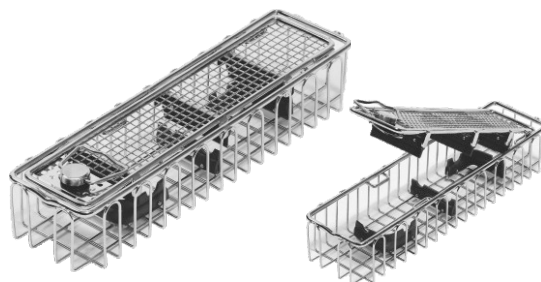

Dimension(mm)

DS-78-4036	290 x 80 x 52
DS-78-4037	460 x 80 x 52

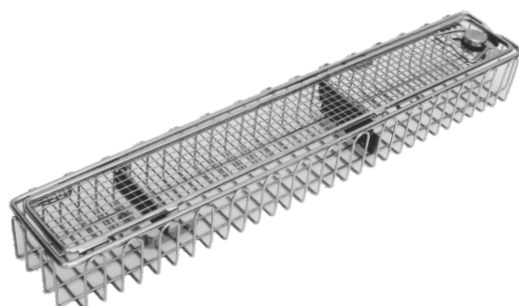

Dimension(mm)

DS-78-4038	670 x 80 x 52
DS-78-4039	700 x 80 x 52



Dimension(mm)

DS-78-4040	290 x 160 x 52
DS-78-4041	310 x 150 x 77
DS-78-4042	460 x 160 x 77
DS-78-4043	640 x 150 x 77
DS-78-4044	660 x 150 x 77
DS-78-4045	460 x 160 x 52
DS-78-4046	580 x 160 x 52

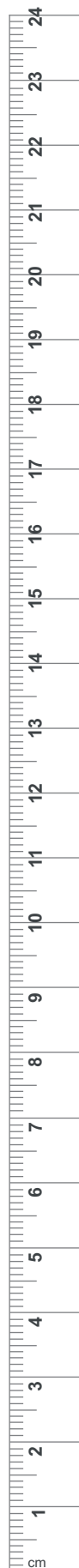

79

EN

Cylinder cartridge syringe

DE

Zylinder-Ampullenspritze

ES

Seringue á ampoule cylindrique

Page 211 to 216

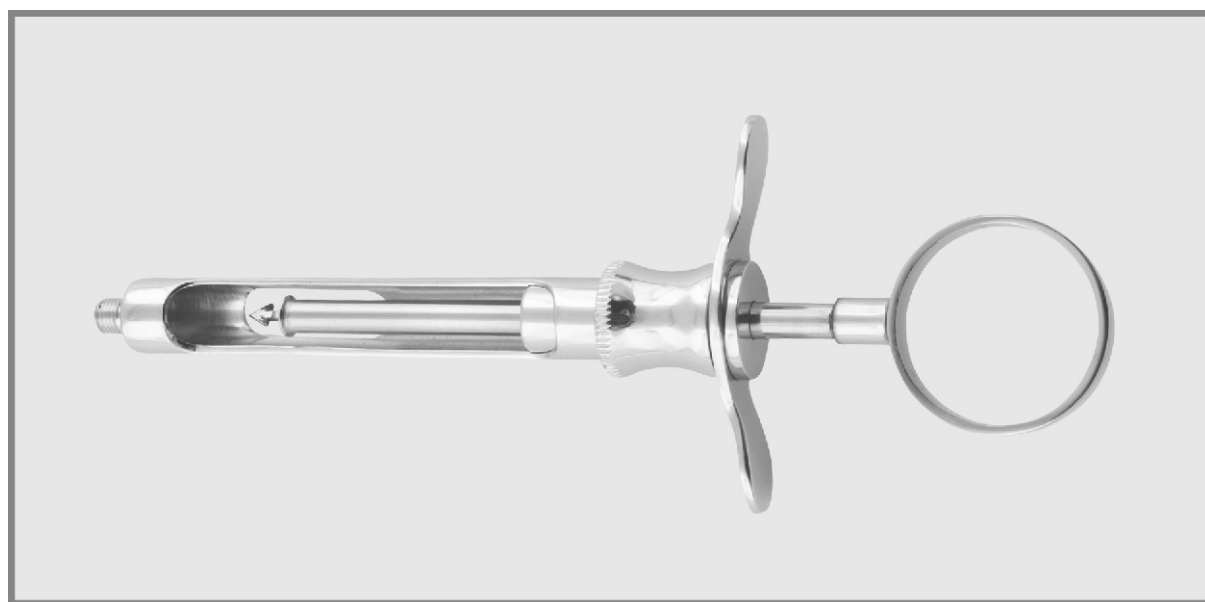



DS-79-4101
 Cylinder cartridge syringe
 1.8 cc, without aspiration
 metric thread / US Thread

DS-79-4103
 Cylinder cartridge syringe
 2.2 cc, without aspiration
 metric thread / US Thread



DS-79-4102
 Cylinder cartridge syringe
 1.8 cc, with aspiration
 metric thread / US Thread

DS-79-4104
 Cylinder cartridge syringe
 2.2 cc, with aspiration
 metric thread / US Thread

DS-79-4105
 Cylinder cartridge syringe
 1.8 cc, without aspiration with
 metric thread / US Thread

DS-79-4107
 Cylinder cartridge syringe
 2.2 cc, without aspiration with
 metric thread / US Thread

DS-79-4106
 Cylinder cartridge syringe
 1.8 cc, with aspiration with
 metric thread / US Thread

DS-79-4108
 Cylinder cartridge syringe
 2.2 cc, with aspiration with
 metric thread / US Thread



DS-79-4109

Cylinder cartridge syringe
 1.8 cc, without aspiration
 metric thread / US Thread

DS-79-4111

Cylinder cartridge syringe
 2.2 cc, without aspiration
 metric thread / US Thread

DS-79-4110

Cylinder cartridge syringe
 1.8 cc, with aspiration
 metric thread / US Thread

DS-79-4112

Cylinder cartridge syringe
 2.2 cc, with aspiration
 metric thread / US Thread



DS-79-4113

Cylinder Cartridge Syringe
 1.8cc without Aspiration
 metric thread / US Thread

DS-79-4115

Cylinder Cartridge Syringe
 2.2cc without Aspiration
 metric thread / US Thread

DS-79-4114

Cylinder Cartridge Syringe
 1.8cc with Aspiration
 metric thread / US Thread

DS-79-4116

Cylinder Cartridge Syringe
 2.2cc with Aspiration
 metric thread / US Thread





DS-79-4117
 Cylinder Cartridge Syringe
 1.8cc without Aspiration
 metric thread / US Thread
 Plastic base & handle sand blast
 finish steel rod.

DS-79-4118
 Cylinder Cartridge Syringe
 1.8cc with Aspiration
 metric thread / US Thread
 Plastic base & handle sand blast
 finish steel rod.

DS-79-4119
 Cylinder Cartridge Syringe
 2.2cc without Aspiration
 metric thread / US Thread
 Plastic base & handle sand blast
 finish steel rod.

DS-79-4120
 Cylinder Cartridge Syringe
 2.2cc with Aspiration
 metric thread / US Thread
 Plastic base & handle sand blast
 finish steel rod.



DS-79-4121
 Cylinder Cartridge Syringe
 1.8cc without Aspiration
 metric thread / US Thread

DS-79-4122
 Cylinder Cartridge Syringe
 1.8cc with Aspiration
 metric thread / US Thread

DS-79-4123
 Cylinder Cartridge Syringe
 2.2cc without Aspiration
 metric thread / US Thread

DS-79-4124
 Cylinder Cartridge Syringe
 2.2cc with Aspiration
 metric thread / US Thread



DS-79-4125
 Cylinder Cartridge Syringe
 1.8cc without Aspiration
 metric thread / US Thread

DS-79-4126
 Cylinder Cartridge Syringe
 1.8cc with Aspiration
 metric thread / US Thread

DS-79-4127
 Cylinder Cartridge Syringe
 2.2cc without Aspiration
 metric thread / US Thread

DS-79-4128
 Cylinder Cartridge Syringe
 2.2cc with Aspiration
 metric thread / US Thread



DS-79-4129
 Cylinder Cartridge Syringe
 1.8cc without Aspiration
 metric thread / US Thread

DS-79-4130
 Cylinder Cartridge Syringe
 1.8cc with Aspiration
 metric thread / US Thread

DS-79-4131
 Cylinder Cartridge Syringe
 2.2cc without Aspiration
 metric thread / US Thread

DS-79-4132
 Cylinder Cartridge Syringe
 2.2cc with Aspiration
 metric thread / US Thread

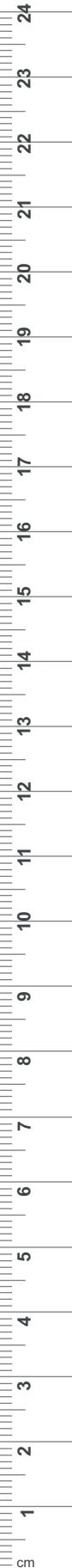



DS-79-4133
 Cylinder Cartridge Syringe
 1.8cc without Aspiration
 metric thread / US Thread

DS-79-4135
 Cylinder Cartridge Syringe
 2.2cc without Aspiration
 metric thread / US Thread

DS-79-4134
 Cylinder Cartridge Syringe
 1.8cc with Aspiration
 metric thread / US Thread

DS-79-4136
 Cylinder Cartridge Syringe
 2.2cc with Aspiration
 metric thread / US Thread



DS-79-4137
 Aspirating Syringe
 1.8cc with fix tip, S/S
 metric thread / US Thread

DS-79-4138
 Aspirating Syringe
 2.2cc with fix tip, S/S
 metric thread / US Thread

Intra-Ligamentale Syringes

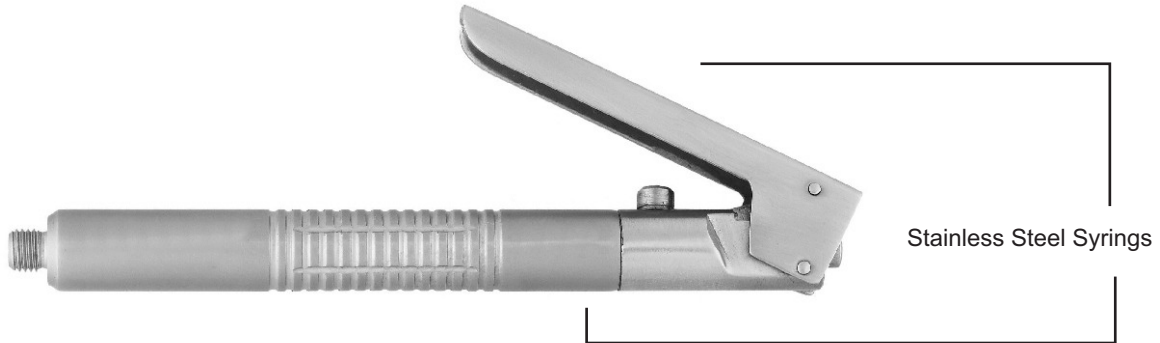

DS-79-4139
1.8 cc metric thread / US Thread
2.2 cc metric thread / US Thread

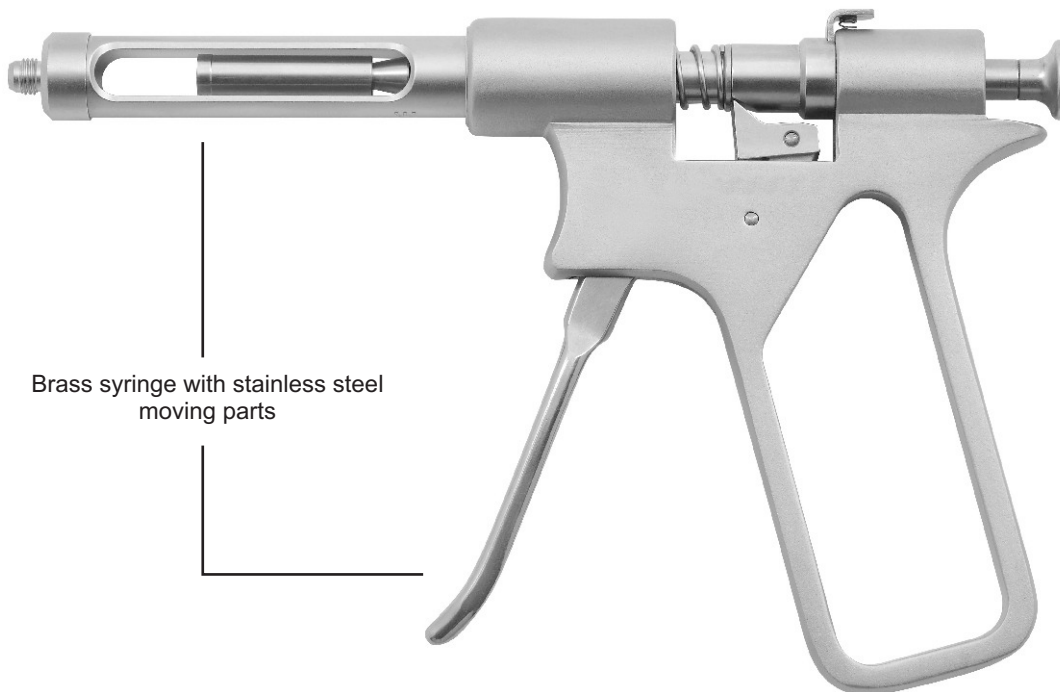

DS-79-4140
1.8 cc metric thread / US Thread
2.2 cc metric thread / US Thread



80

- EN** Impression Trays
- DE** Abdrucklöffel
- ES** Porte empreintes

Page 217 to 228

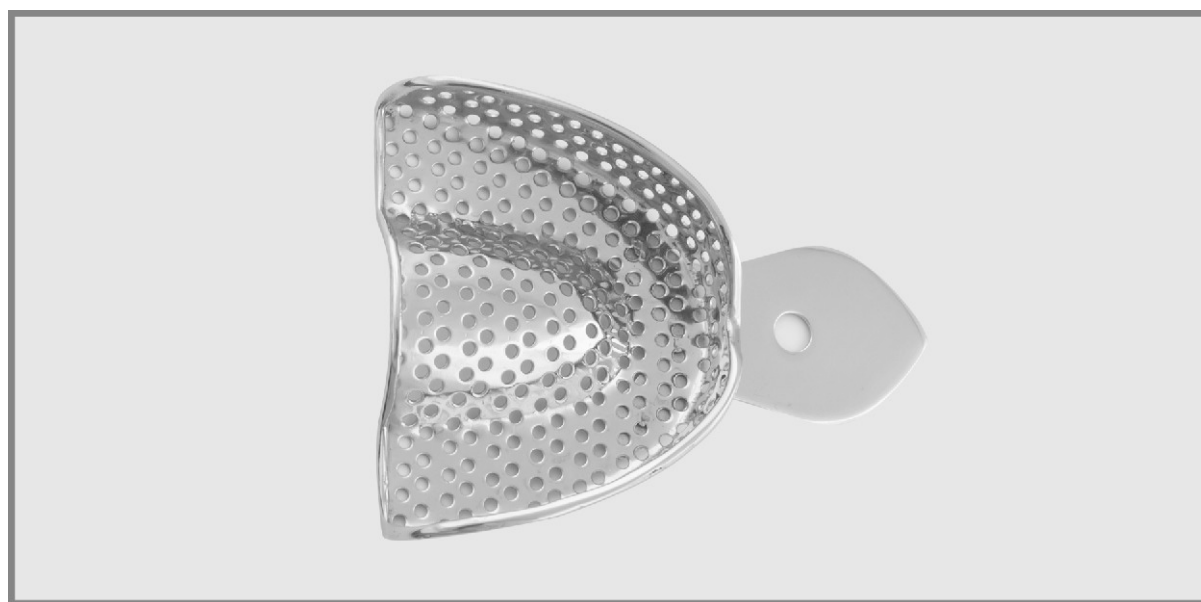

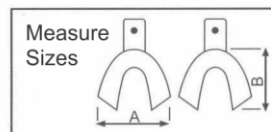
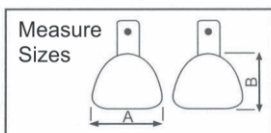
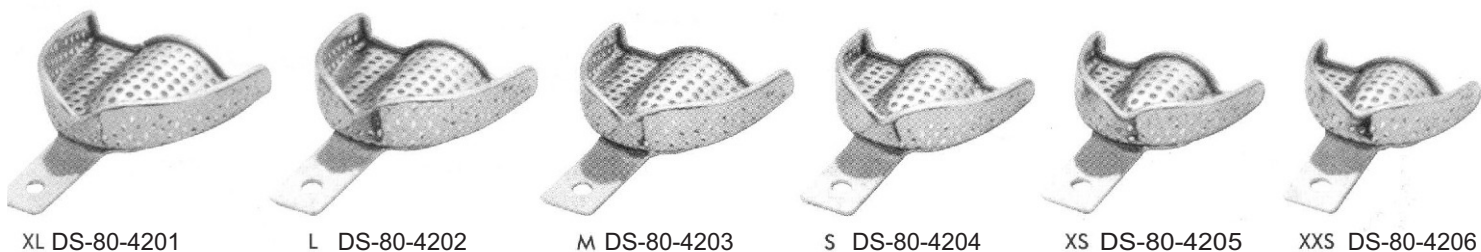

Upper		A (left-right)	B (top-bottom)
80-4201	XL	81 mm	63 mm
80-4202	L	73 mm	58 mm
80-4203	M	71 mm	52 mm
80-4204	S	67 mm	53 mm
80-4205	XS	65 mm	51 mm
80-4206	XXS	61 mm	50 mm

Lower		A (left-right)	B (top-bottom)
80-4207	XL	78 mm	63 mm
80-4208	L	74 mm	62 mm
80-4209	M	72 mm	59 mm
80-4210	S	70 mm	57 mm
80-4211	XS	69 mm	55 mm
80-4212	XXS	59 mm	50 mm

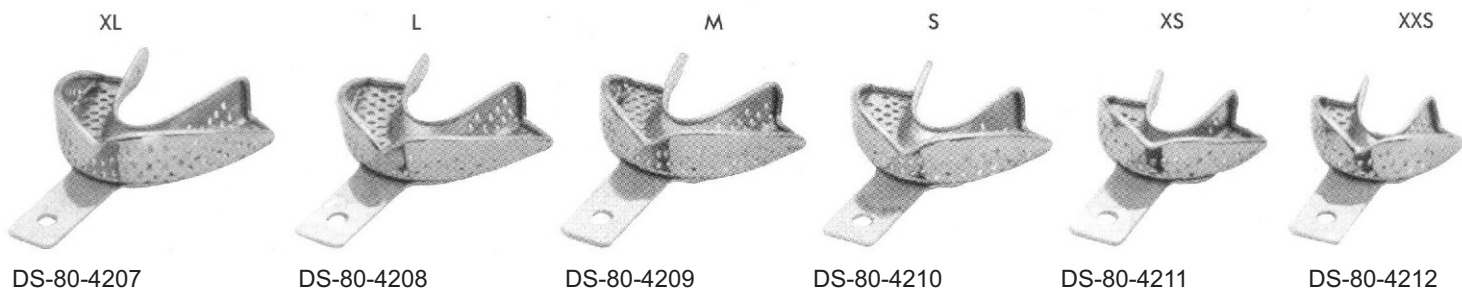

DS-80-4207 DS-80-4208 DS-80-4209 DS-80-4210 DS-80-4211 DS-80-4212

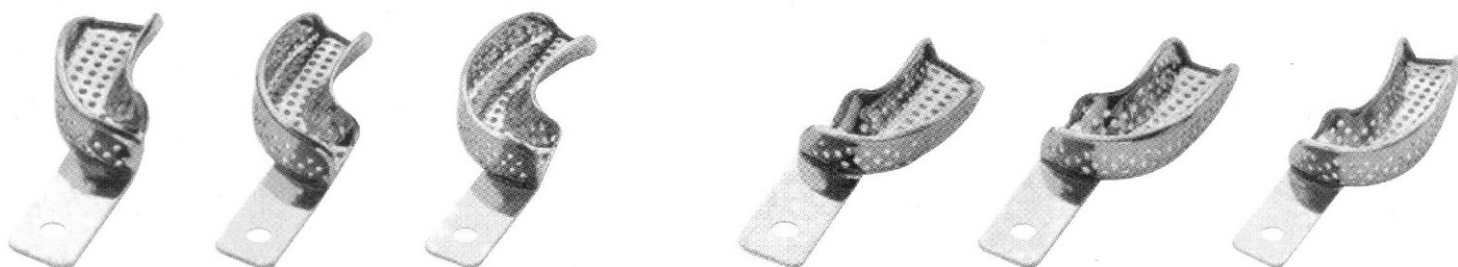

DS-80-4213 DS-80-4214 DS-80-4215 DS-80-4216 DS-80-4217 DS-80-4218

IMPRESSION TRAYS

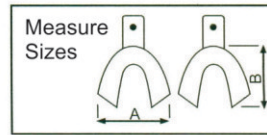
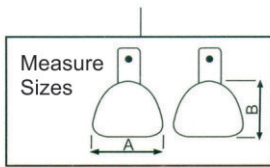
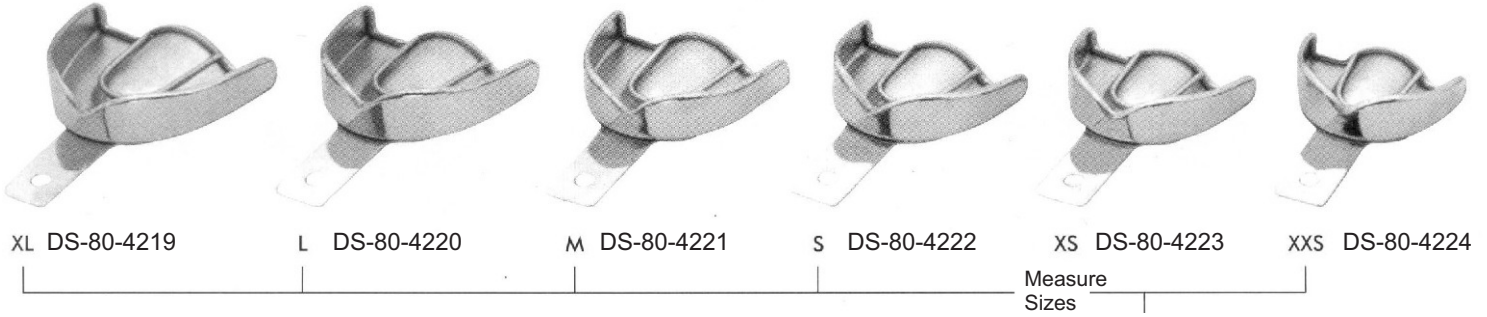

Upper		A (left-right)	B (top-bottom)
81-4219	XL	81 mm	63 mm
81-4220	L	73 mm	58 mm
81-4221	M	71 mm	52 mm
81-4222	S	67 mm	53 mm
81-4223	XS	65 mm	51 mm
81-4224	XXS	61 mm	50 mm

Lower		A (left-right)	B (top-bottom)
81-4225	XL	78 mm	63 mm
81-4226	L	74 mm	62 mm
81-4227	M	72 mm	59 mm
81-4228	S	70 mm	57 mm
81-4229	XS	69 mm	55 mm
81-4201	XXS	59 mm	50 mm

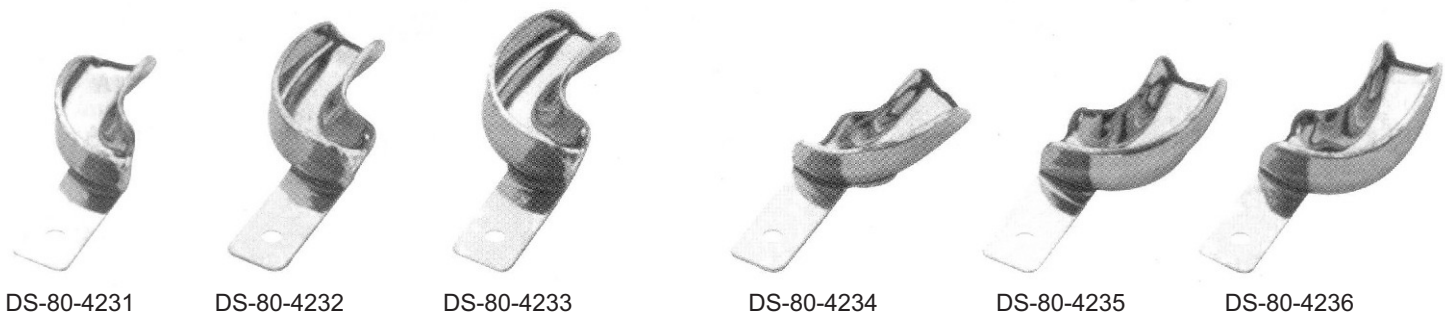
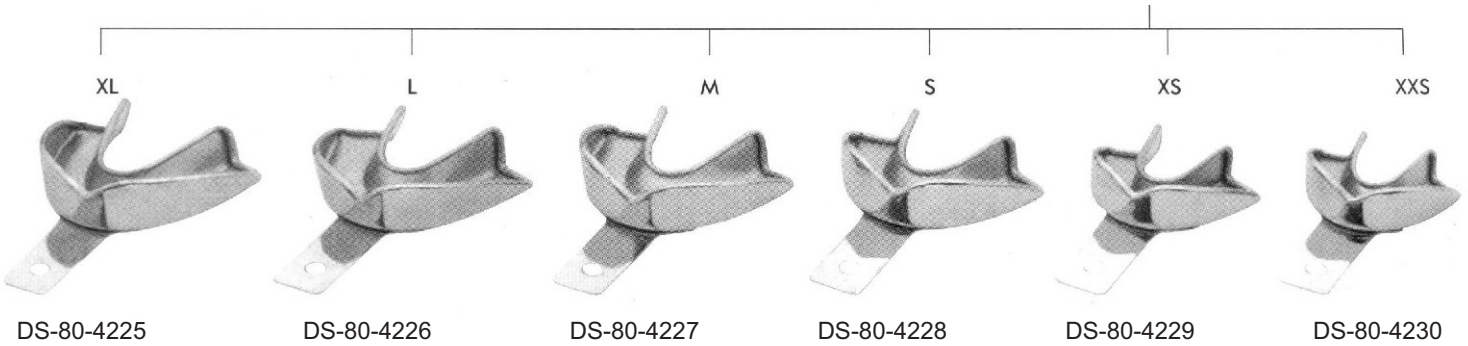

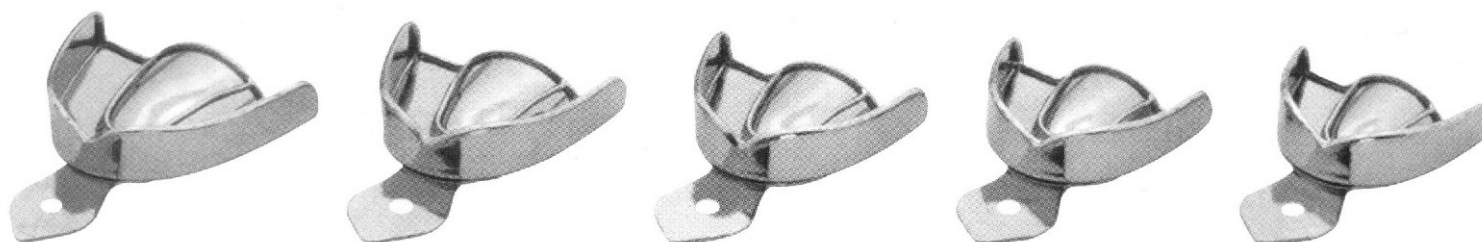

DS-80-4237

DS-80-4238

DS-80-4239

DS-80-4240

DS-80-4241

XL

L

M

S

XS

Upper		A (left-right)	B (top-bottom)
DS-80-4237	XL	81 mm	63 mm
DS-80-4238	L	73 mm	58 mm
DS-80-4239	M	71 mm	52 mm
DS-80-4240	S	67 mm	53 mm
DS-80-4241	XS	65 mm	51 mm

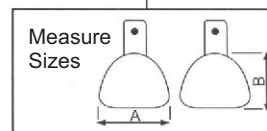

Lower		A (left-right)	B (top-bottom)
DS-80-4242	XL	78 mm	63 mm
DS-80-4243	L	74 mm	62 mm
DS-80-4244	M	72 mm	59 mm
DS-80-4245	S	70 mm	57 mm
DS-80-4246	XS	69 mm	55 mm

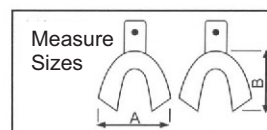

XL

L

M

S

XS

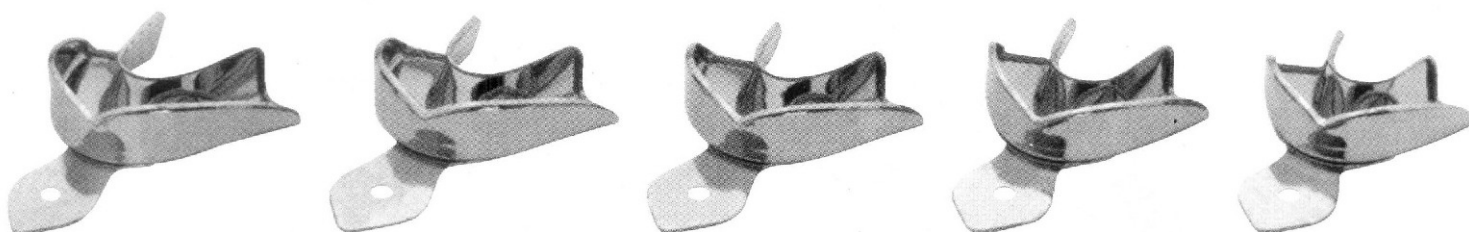

DS-80-4242

DS-80-4243

DS-80-4244

DS-80-4245

DS-80-4246

IMPRESSION TRAYS

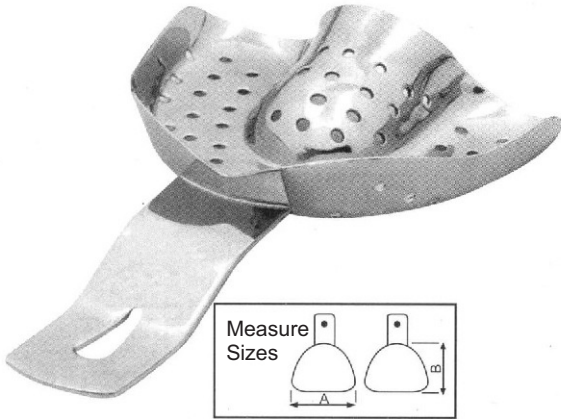

For Toothed Upper Jaws
(Fig. 0 for children)

	A mm.	B mm.
DS-80-4247 0	59	52
DS-80-4248 1	66	52
DS-80-4249 2	71	62
DS-80-4250 3	71	64
DS-80-4251 4	80	70

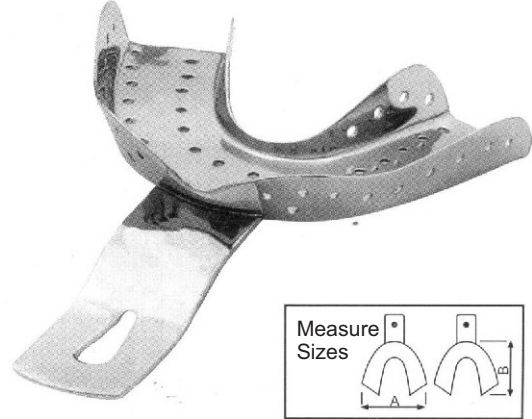

For Toothed Lower Jaws
(Fig. 0 for children)

	A mm.	B mm.
DS-80-4252 0	65	46
DS-80-4253 1	67	50
DS-80-4254 2	76	54
DS-80-4255 3	79	56
DS-80-4256 4	79	61

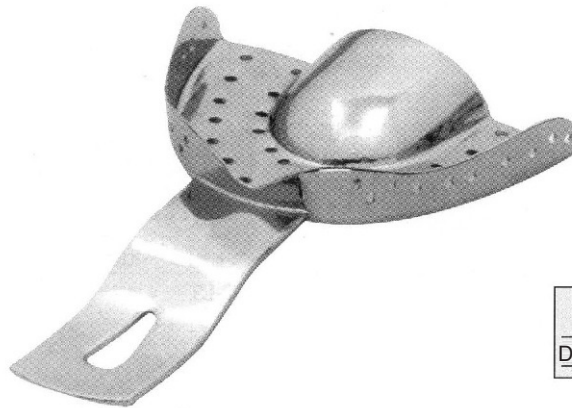

For Narrow Toothed Upper Jaws

	A mm.	B mm.
DS-80-4257 2	70	54

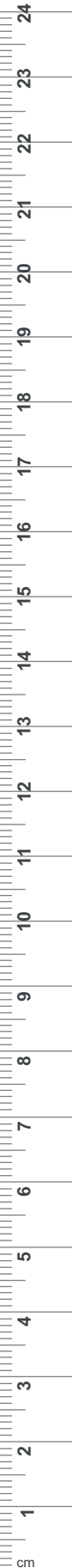

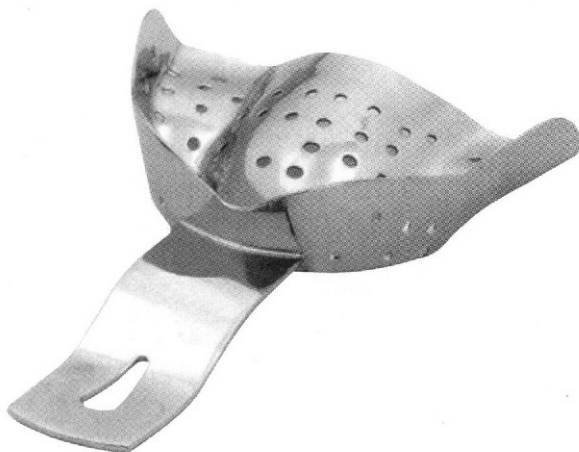

For partially toothed upper jaws

	A mm.	B mm.
DS-80-4258 1	62	50
DS-80-4259 2	70	56

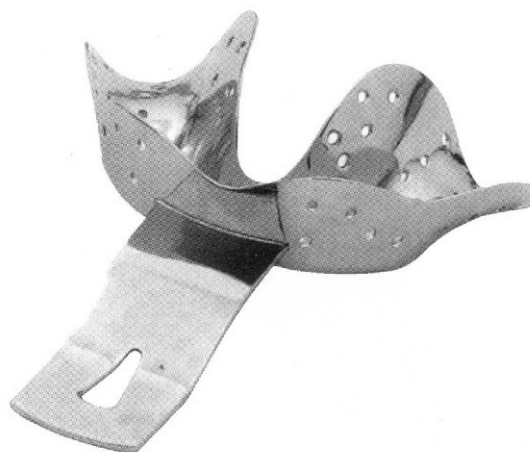
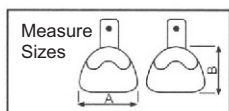

For partially toothed lower jaws

	A mm.	B mm.
DS-80-4260 1	70	55
DS-80-4261 2	78	59

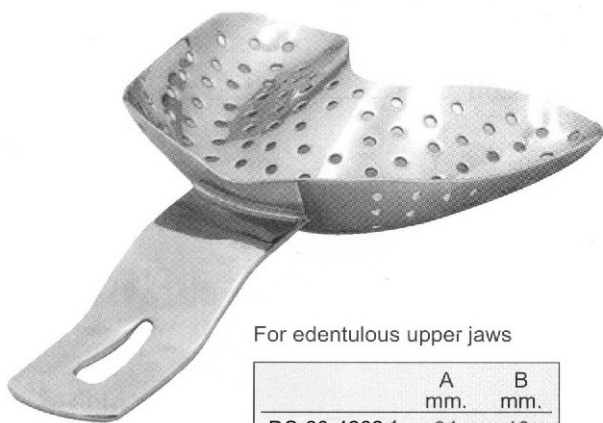
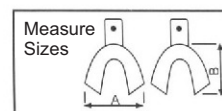

For edentulous upper jaws

	A mm.	B mm.
DS-80-4262 1	64	46
DS-80-4263 2	68	53
DS-80-4264 3	79	61

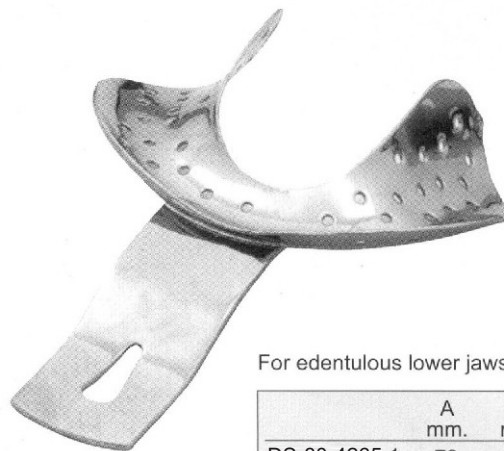

For edentulous lower jaws

	A mm.	B mm.
DS-80-4265 1	70	48
DS-80-4266 2	70	53
DS-80-4267 3	72	57

IMPRESSION TRAYS



Solid stainless steel anterior depressed impression trays with retention rim.

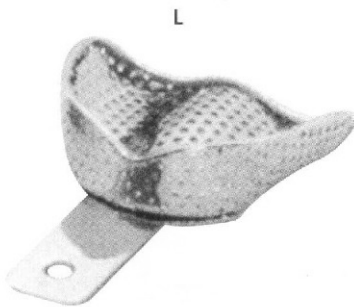
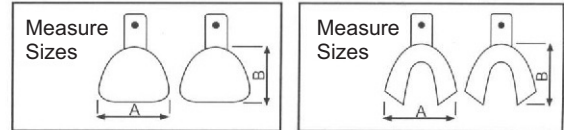

DS-80-4268

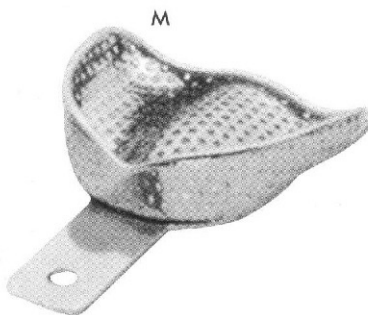

DS-80-4269

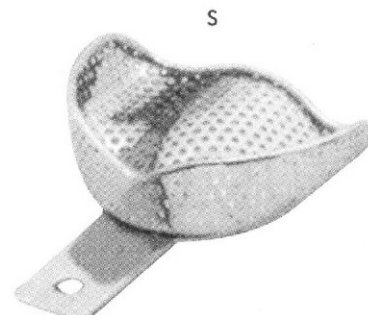

DS-80-4270

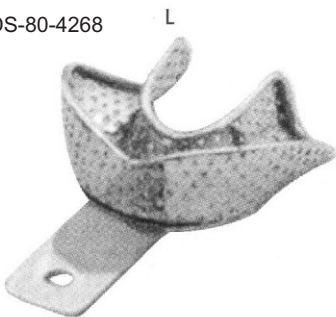

DS-80-4271

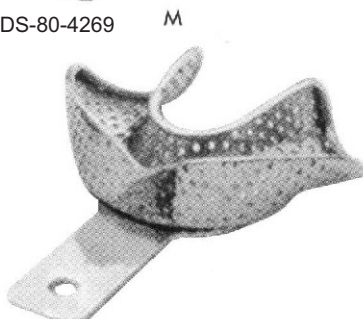

DS-80-4272



DS-80-4273

		A	B
		mm.	mm.
DS-80-4268	L	81	67
DS-80-4269	M	71	64
DS-80-4270	S	70	57

		A	B
		mm.	mm.
DS-80-4271	L	81	60
DS-80-4272	M	79	57
DS-80-4273	S	76	54

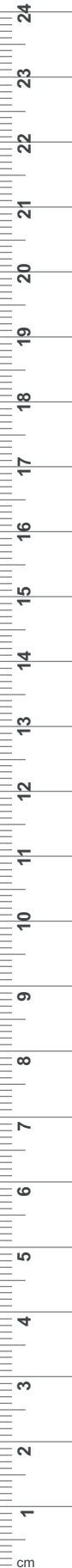



Solid total denture stainless steel impression trays with rim.

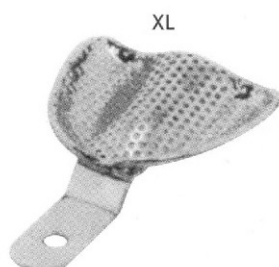
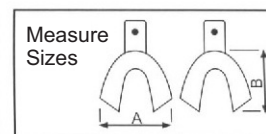
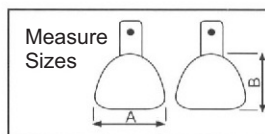

DS-80-4274

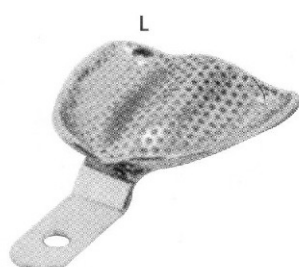

DS-80-4275

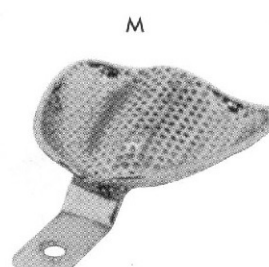

DS-80-4276

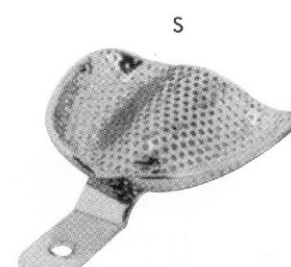

DS-80-4277

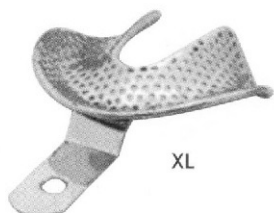

DS-80-4278

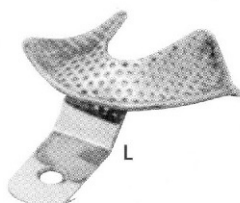

DS-80-4279

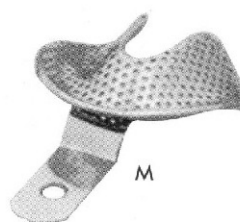

DS-80-4280

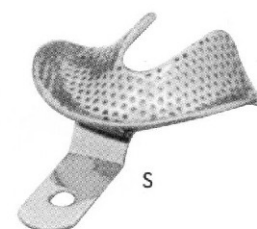

DS-80-4281

	A mm.	B mm.
DS-80-4274 XL	79	70
DS-80-4275 L	76	67
DS-80-4276 M	70	64
DS-80-4277 S	73	60

	A mm.	B mm.
DS-80-4278 XL	86	64
DS-80-4279 L	70	64
DS-80-4280 M	73	60
DS-80-4281 S	70	57

IMPRESSION TRAYS

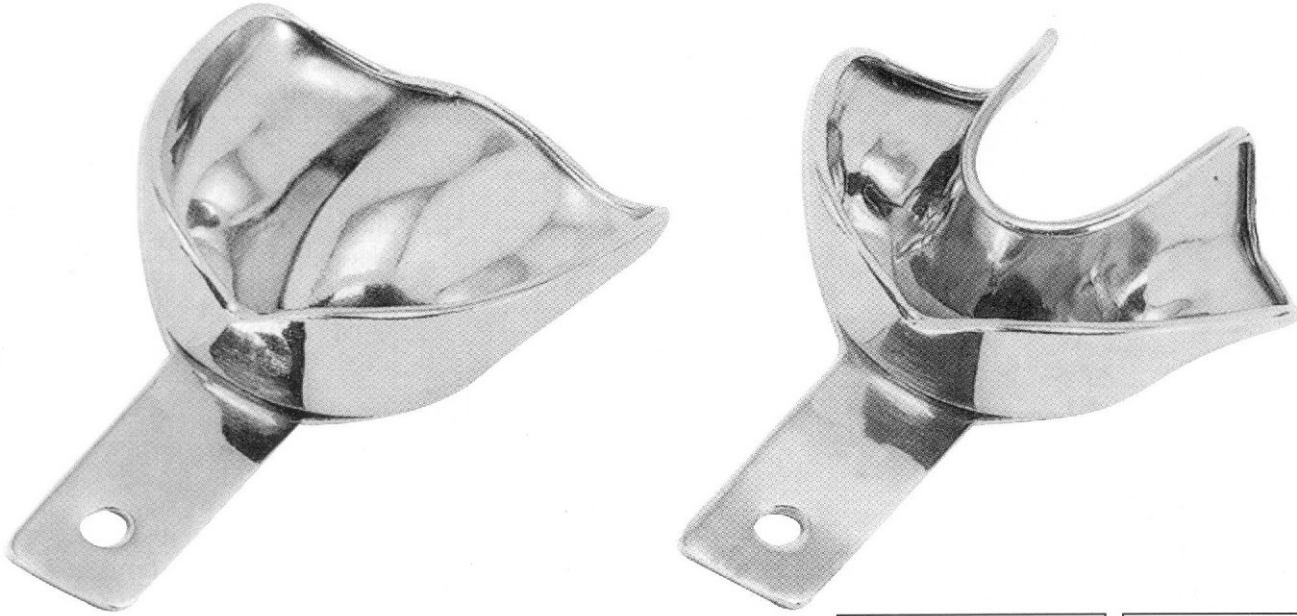

Solid stainless steel anterior depressed impression trays with retention rim.

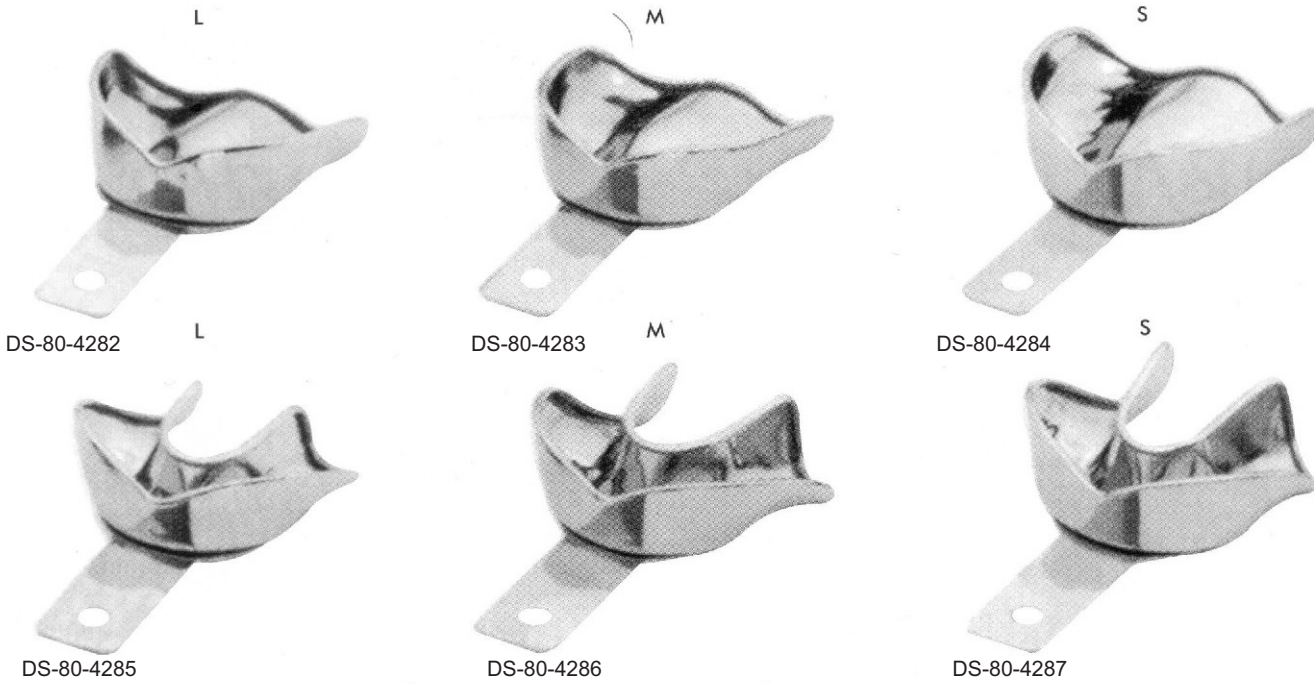
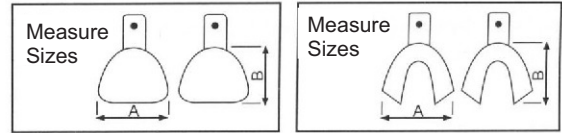

	A mm.	B mm.
DS-80-4282	81	67
DS-80-4283	71	64
DS-80-4284	70	57

	A mm.	B mm.
DS-80-4285 L	81	60
DS-80-4286 M	79	57
DS-80-4287 S	76	54

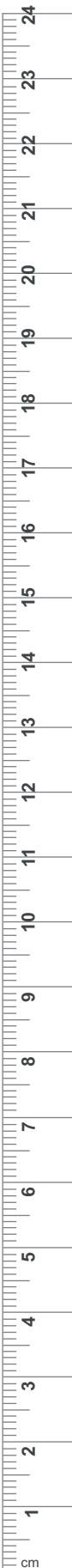

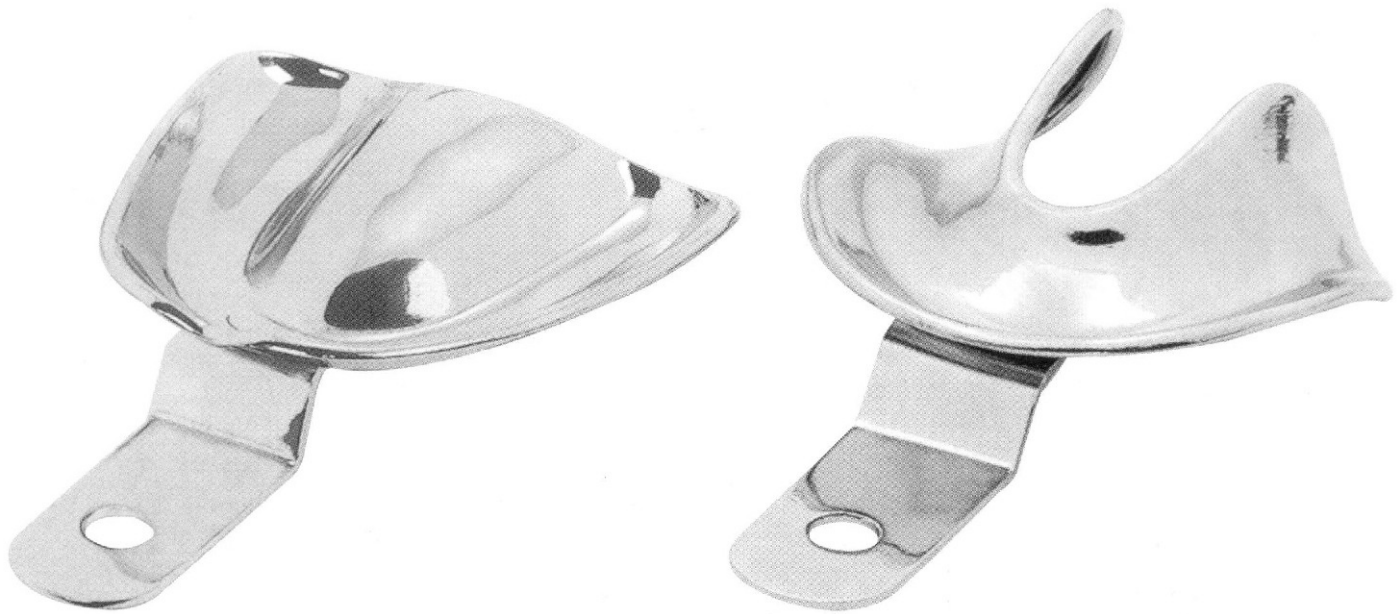

Solid total denture stainless steel impression trays with rim.

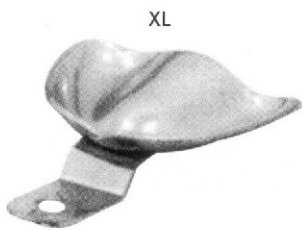
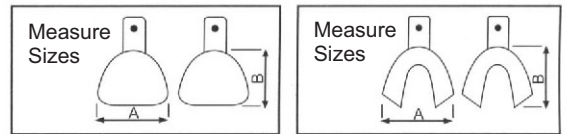

DS-80-4288

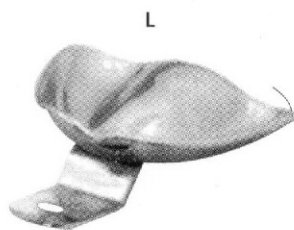

DS-80-4289

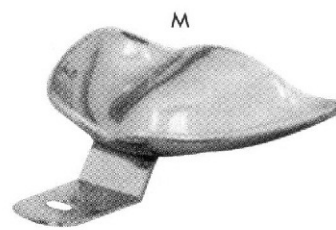

DS-80-4290

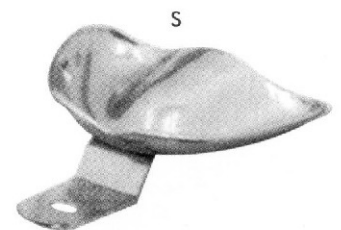

DS-80-4291



DS-80-4292



DS-80-4293

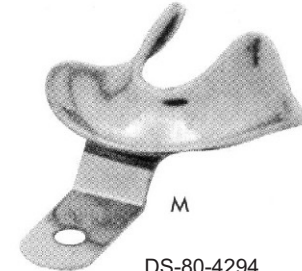

DS-80-4294

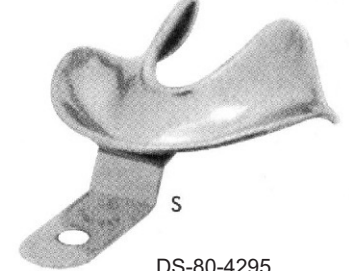

DS-80-4295

	A mm.	B mm.
DS-80-4288XL	79	70
DS-80-4289 L	76	67
DS-80-4290M	70	64
DS-80-4291 S	73	60

	A mm.	B mm.
DS-80-4292 XL	86	64
DS-80-4293 L	70	64
DS-80-4294 M	73	60
DS-80-4295 S	70	57

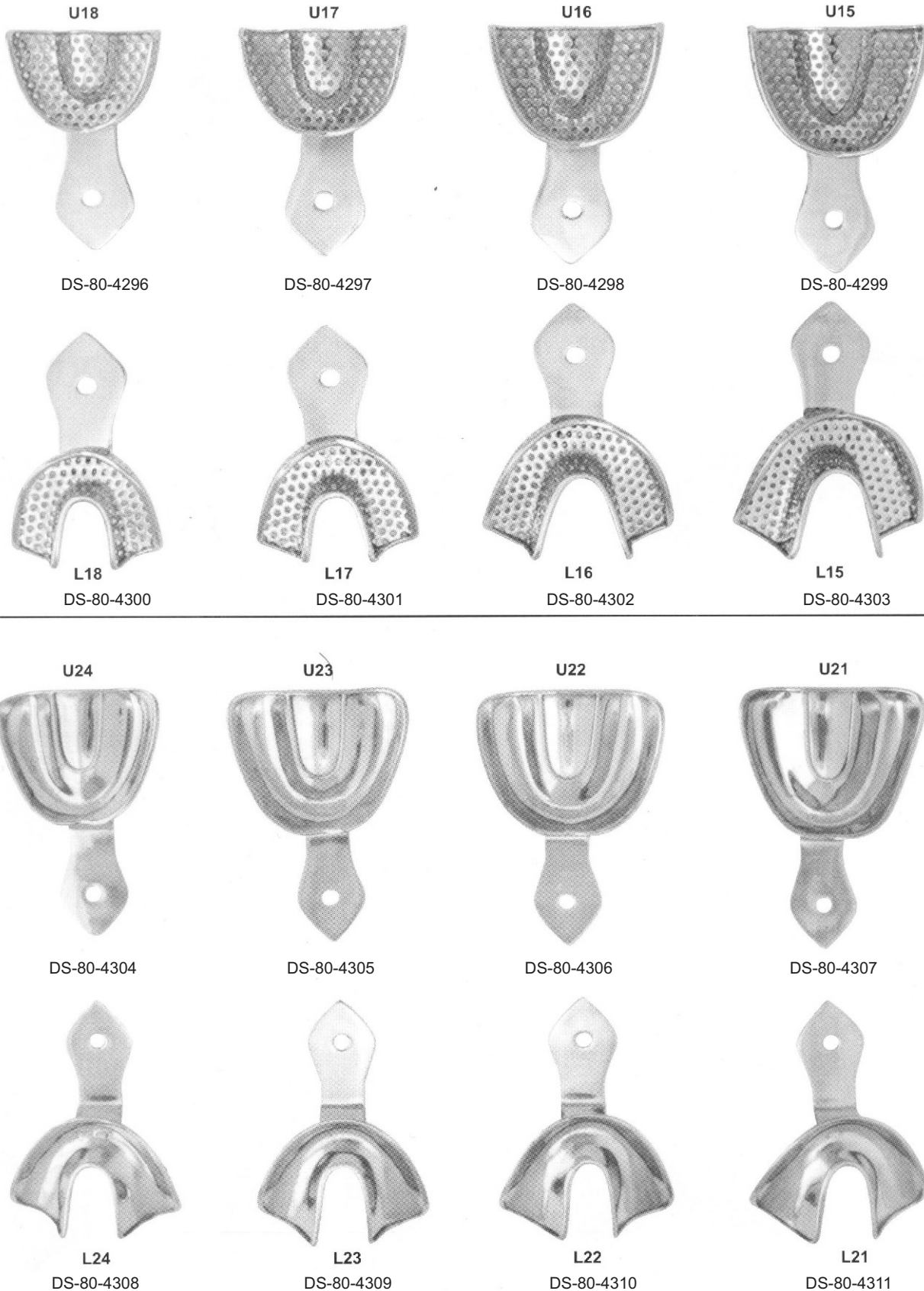

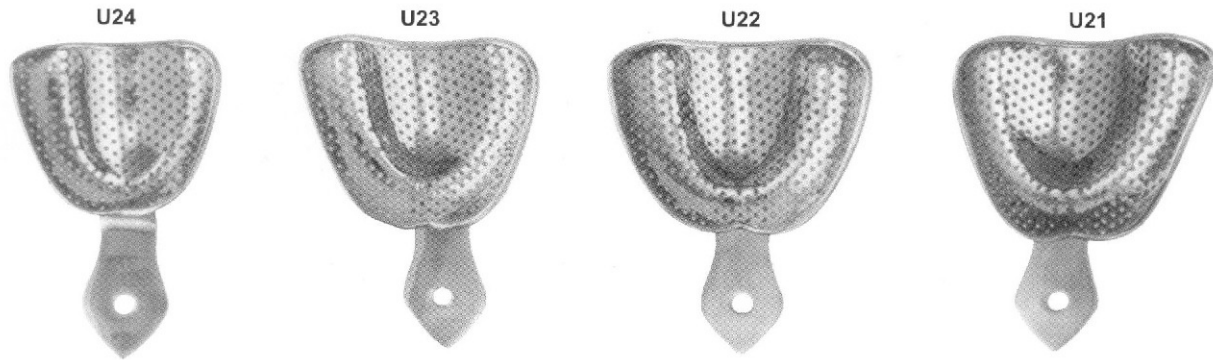

DS-80-4312

DS-80-4313

DS-80-4314

DS-80-4315



L24
DS-80-4316

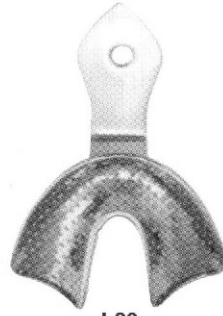

L23
DS-80-4317



L22
DS-80-4318

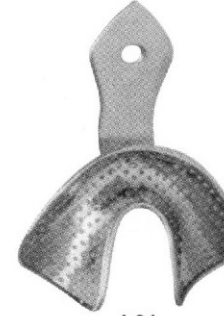

L21
DS-80-4319



DS-80-4320

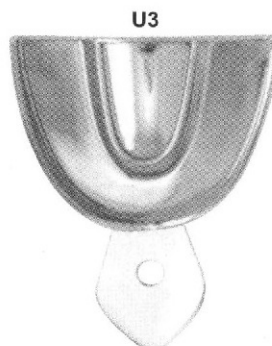

DS-80-4321



DS-80-4322

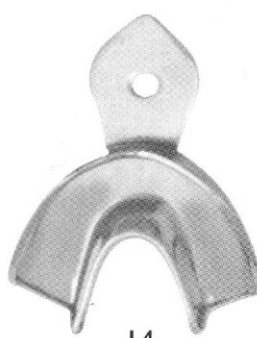

L4
DS-80-4323

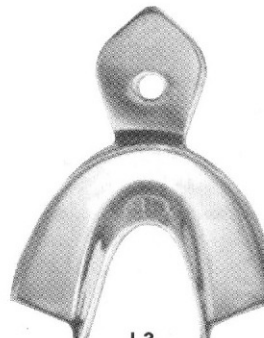

L3
DS-80-4324

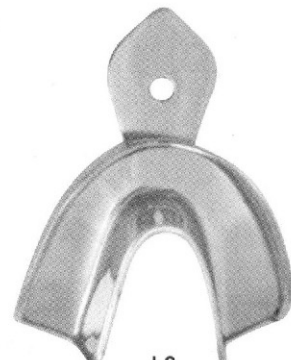

L2
DS-80-4325

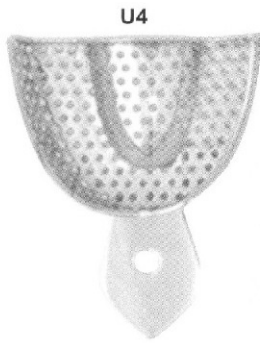

DS-80-4326

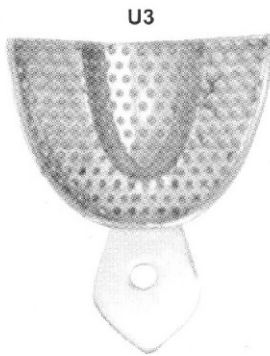

DS-80-4327

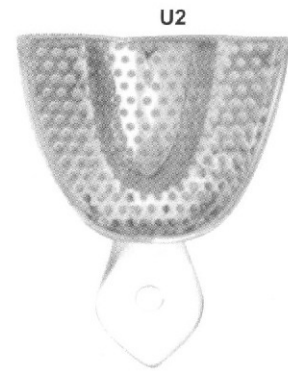

DS-80-4328

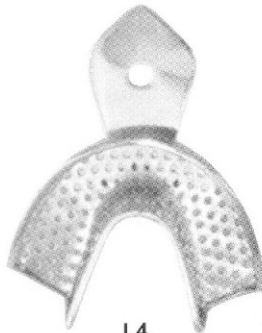

DS-80-4329

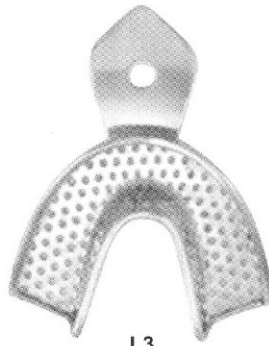

DS-80-4330

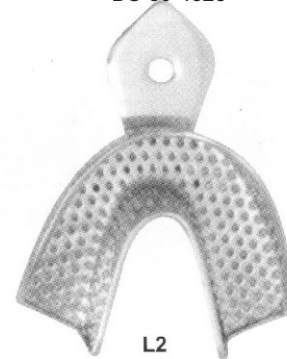

DS-80-4331



DS-80-4332



DS-80-4333



DS-80-4334



DS-80-4335



DS-80-4336



DS-80-4337

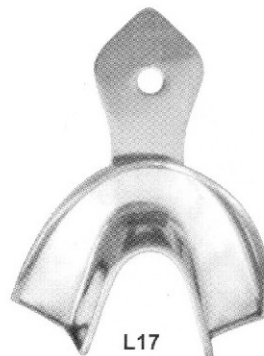

DS-80-4338

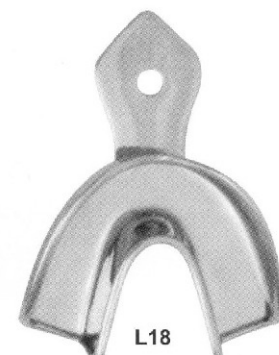

DS-80-4339

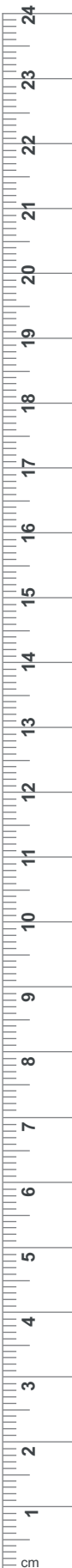

81

- EN** Articulators
- DE** Artikulatoren
- ES** Articuladores

Page 229 to 230



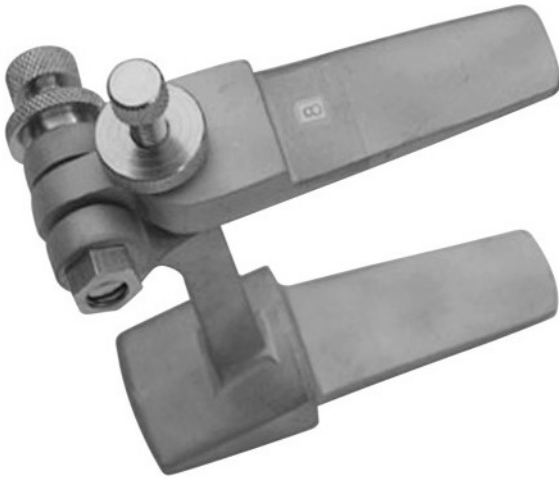

DS-81-4301



DS-81-4302



DS-81-4303



DS-81-4304



DS-81-4306



DS-81-4305

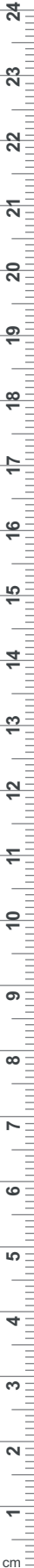

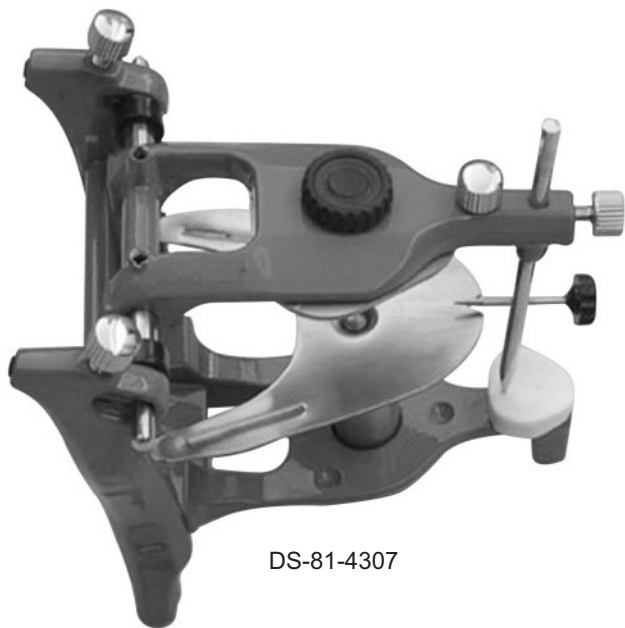

DS-81-4307



DS-81-4308



DS-81-4309



DS-81-4310



DS-81-4311



DS-81-4312

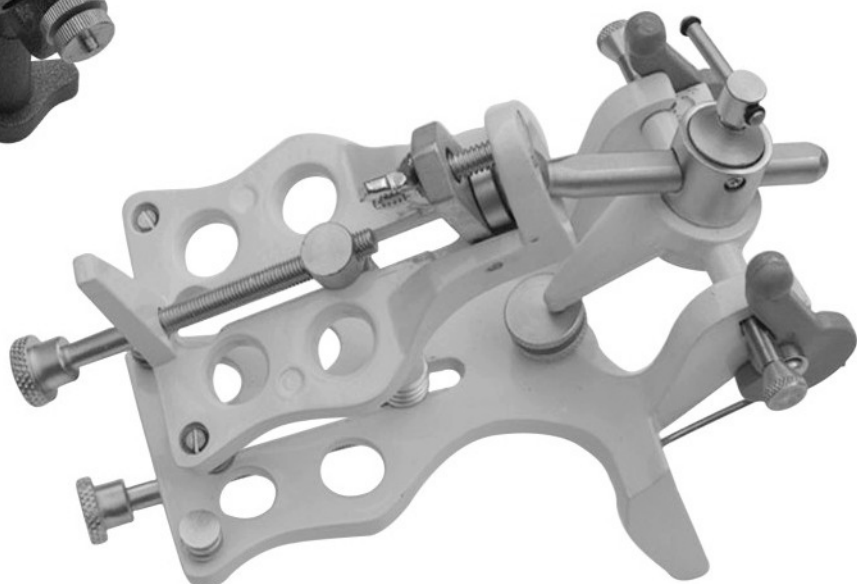

DS-81-4313

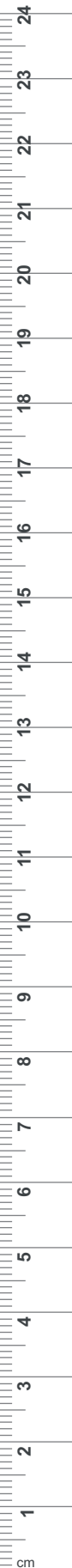

82

EN	Holloware
DE	Holloware
ES	holloware

Page 231 to 234





Needle Case Round with Cover
 DS-82-4401 65x15mm



Needle Case Round
 DS-82-4402 80x20mm



Needle Case Rectangle
 DS-82-4403 70x70x10mm



Endodontic Box
 DS-82-4404
 100x40x50mm

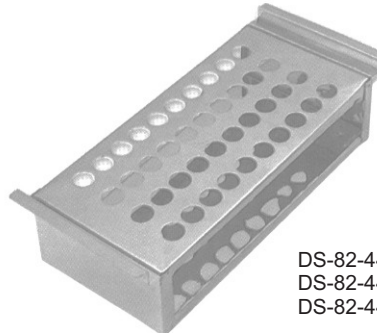

Tube Rack

DS-82-4405 6.35x15.25x5cm for 12 tubes
 DS-82-4406 6.35x17.75x7.5cm for 27 tubes
 DS-82-4407 7.50x17.75x6.35cm for 36 tubes



Sprit Lamp
 DS-82-4408
 Standard Size



Sprit Lamp
 DS-82-4409
 Standard Size



Sputum Cup

DS-82-4410 75x80mm
 DS-82-4411 100x50mm
 DS-82-4412 100x80mm



Dressing Jar

DS-82-4413	80x60mm	DS-82-4420
DS-82-4414	80x80mm	DS-82-4421
DS-82-4415	100x100mm	DS-82-4423
DS-82-4416	120x120mm	DS-82-4424
DS-82-4417	150x150mm	DS-82-4425
DS-82-4418	180x180mm	DS-82-4426
DS-82-4419	200x200mm	DS-82-4427



Dressing Jar



Fennle

DS-82-4428 100mm Ø
 DS-82-4429 120mm Ø
 DS-82-4430 150mm Ø
 DS-82-4431 200mm Ø



Cotton Holder
 DS-82-4432



Cotton Holder
 DS-82-4433

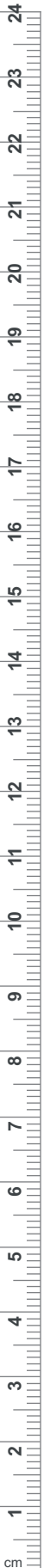



Forceps Jar

- DS-82-4434 30x90mm
- DS-82-4435 50x125mm
- DS-82-4436 50x170mm
- DS-82-4437 50x200mm
- DS-82-4438 40x230mm
- DS-82-4439 70x110mm
- DS-82-4440 80x150mm
- DS-82-4441 100x200mm
- DS-82-4442 150x30mm



Medicine Cup

- DS-82-4461 50ml
- DS-82-4462 60ml
- DS-82-4463 70ml



Kick Bucket with Trolley

- 30-6819-01
- 390x280x180mm

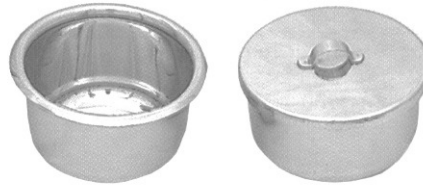

Gallipot

- | | |
|------------------|------------------|
| DS-82-4443 01 oz | DS-82-4450 09 oz |
| DS-82-4444 02 oz | DS-82-4451 10 oz |
| DS-82-4445 03 oz | DS-82-4452 11 oz |
| DS-82-4446 04 oz | DS-82-4453 12 oz |
| DS-82-4447 05 oz | DS-82-4454 13 oz |
| DS-82-4448 06 oz | DS-82-4455 14 oz |
| DS-82-4448 07 oz | DS-82-4456 15 oz |
| DS-82-4449 08 oz | DS-82-4457 16 oz |



Sponge Bowl

- DS-82-4458 12 cm
- DS-82-4459 15 cm
- DS-82-4460 20 cm



Lotion Bowl without spout

- | | |
|---------------------|----------------------|
| DS-82-4464 40x19mm | DS-82-4471 150x65mm |
| DS-82-4465 50x25mm | DS-82-4472 180x85mm |
| DS-82-4466 60x30mm | DS-82-4473 200x100mm |
| DS-82-4467 80x40mm | DS-82-4474 250x120mm |
| DS-82-4468 100x50mm | DS-82-4475-12 300mm |
| DS-82-4469 120x60mm | DS-82-4476-13 350mm |
| DS-82-4470 140x60mm | DS-82-4477-14 400mm |



Wash Basin

- DS-82-4478 300x80mm
- DS-82-4479 320x85mm
- DS-82-4480 330x90mm
- DS-82-4481 350x110mm
- DS-82-4482 400x115mm



Kidney Tray

- DS-82-4486 12cm
- DS-82-4487 15cm
- DS-82-4488 18cm
- DS-82-4489 20cm
- DS-82-4490 25cm
- DS-82-4491 28cm
- DS-82-4492 30cm



Kidney Tray Shallow

- DS-82-4483 17cm
- DS-82-4484 22cm
- DS-82-4485 24cm



Kidney Tray (with cover)

- DS-82-4493 15cm
- DS-82-4494 20cm
- DS-82-4495 25cm
- DS-82-4496 30cm

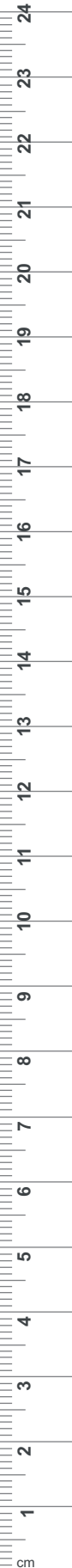

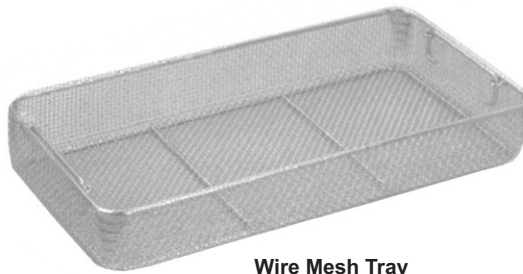

Wire Mesh Tray

- DS-82-4497 240x250x5mm
- DS-82-4498 480x250x5mm
- DS-82-4499 550x250x5mm
- DS-82-4500 240x250x7mm
- DS-82-4501 480x250x7mm
- DS-82-4502 240x250x10mm
- DS-82-4503 480x250x10mm

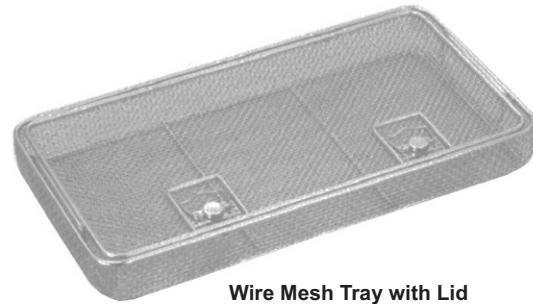

Wire Mesh Tray with Lid

- DS-82-4504 240x250x5mm
- DS-82-4505 480x250x5mm
- DS-82-4506 550x250x5mm
- DS-82-4507 240x250x7mm
- DS-82-4508 480x250x7mm
- DS-82-4509 240x250x10mm
- DS-82-4510 480x250x10mm



Perforated Tray

- DS-82-4511 200x100x40mm
- DS-82-4512 250x120x50mm
- DS-82-4513 300x150x50mm
- DS-82-4514 350x170x50mm
- DS-82-4515 400x200x50mm



Instruments Tray without Lid

- DS-82-4516 100x150x25mm
- DS-82-4517 150x200x40mm
- DS-82-4518 200x250x45mm
- DS-82-4519 250x300x50mm
- DS-82-4520 300x350x50mm
- DS-82-4521 150x300x50mm
- DS-82-4522 200x300x50mm
- DS-82-4523 230x150x50mm



Instruments Tray with Lid

- DS-82-4524 100x150x25mm
- DS-82-4525 150x200x40mm
- DS-82-4526 200x250x45mm
- DS-82-4527 250x300x50mm
- DS-82-4528 300x350x50mm
- DS-82-4529 150x300x50mm
- DS-82-4530 200x300x50mm
- DS-82-4531 230x150x50mm

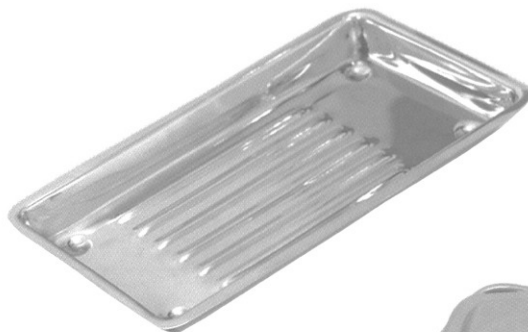

Burr Tray

- DS-82-4532
190x100x20mm

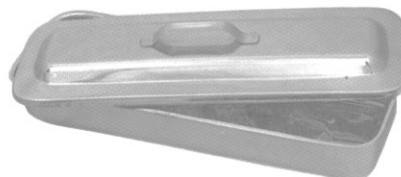

Cathetes Tray with Lid

- DS-82-4533 300x80x40mm
- DS-82-4534 350x90x45mm
- DS-82-4535 400x100x50mm

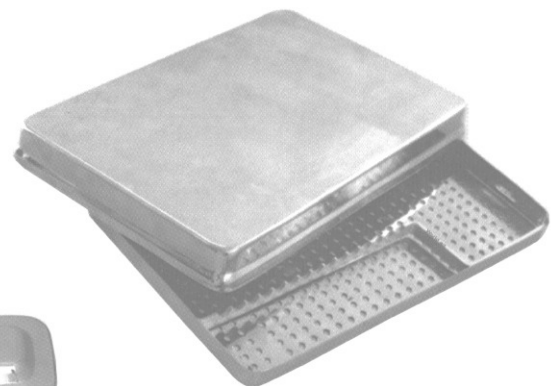

Scaler Tray with cover

- DS-82-4536
200x100x16mm

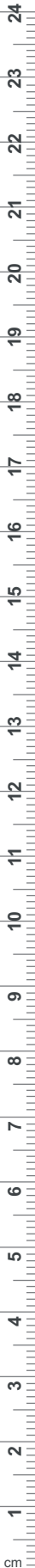

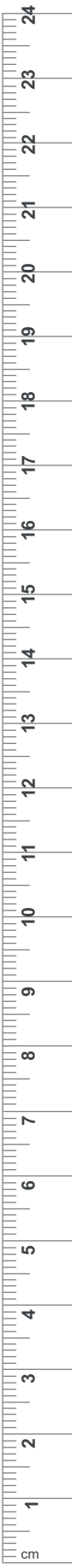

**Instruments Box
with Hooks**

- DS-82-4537 170x70x30mm
- DS-82-4538 180x80x40mm
- DS-82-4539 200x100x40mm
- DS-82-4540 230x120x50mm
- DS-82-4541 250x125x50mm
- DS-82-4542 300x150x50mm
- DS-82-4543 350x170x50mm
- DS-82-4544 400x200x90mm
- DS-82-4545 500x200x120mm



Instruments Box

- DS-82-4546 170x70x30mm
- DS-82-4547 180x80x40mm
- DS-82-4548 200x100x40mm
- DS-82-4549 230x120x50mm
- DS-82-4550 250x125x50mm
- DS-82-4551 300x150x50mm
- DS-82-4552 350x170x50mm
- DS-82-4553 400x200x90mm
- DS-82-4554 500x200x120mm



**Instruments Box
Perforated**

- DS-82-4555 200x100x40mm
- DS-82-4556 250x150x40mm
- DS-82-4557 300x150x40mm



Electric Sterilizer

- DS-82-4558 200x100x120mm
- DS-82-4559 250x120x140mm
- DS-82-4560 300x150x150mm
- DS-82-4561 350x170x170mm
- DS-82-4562 400x200x180mm
- DS-82-4563 450x230x190mm



Non Electric Sterilizer

- DS-82-4564 200x100x65mm
- DS-82-4565 250x125x65mm
- DS-82-4566 300x150x100mm
- DS-82-4567 350x170x65mm
- DS-82-4568 400x200x100mm



Electric Sterilizer
 DS-82-4569
 280x125x65mm

- DS-82-4570 125x80mm
- DS-82-4571 125x120mm
- DS-82-4572 150x100mm
- DS-82-4573 150x150mm
- DS-82-4574 180x180mm
- DS-82-4575 190x140mm
- DS-82-4576 190x190mm
- DS-82-4577 200x200mm
- DS-82-4578 240x120mm
- DS-82-4579 240x240mm
- DS-82-4580 290x140mm
- DS-82-4581 290x240mm
- DS-82-4582 290x290mm
- DS-82-4583 340x160mm
- DS-82-4584 340x340mm
- DS-82-4585 390x150mm
- DS-82-4586 390x200mm
- DS-82-4587 390x290mm



Sterilizer Drum

Dsurgical Instruments

Address: Sialkot, Punjab, Pakistan

Web: dsurgicalinstruments.com

Phone: +92 318 7301089

Email: Cheematayyab405@gmail.com

umerjaved904@gmail.com

info@dsurgicalinstruments.com

sales@dsurgicalinstruments.com